

T4BJ SERIES

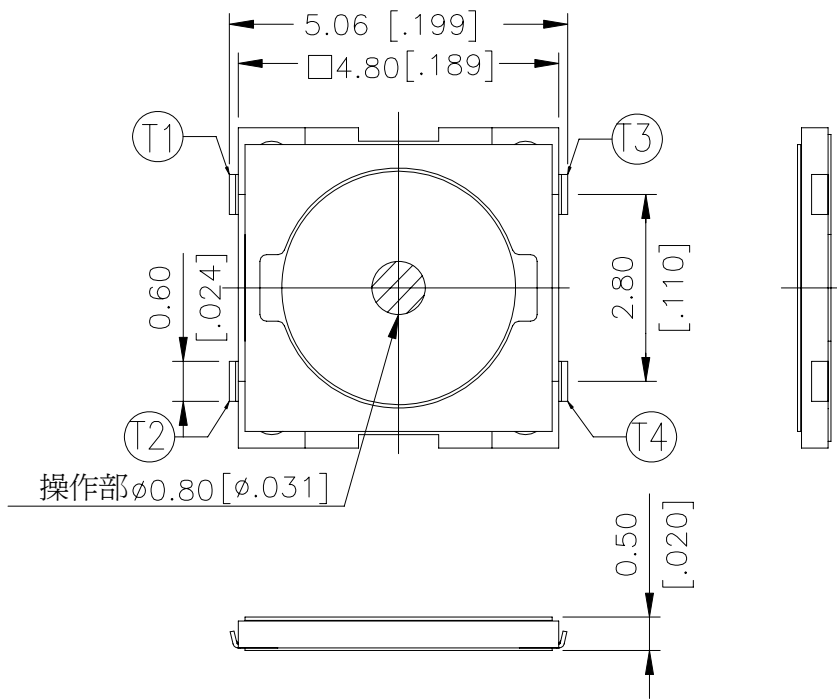

**DIMENSION**

**T4BJA**



| PART NO   | OF    |
|-----------|-------|
| T4BJA10-Q | 100gf |
| T4BJA16-Q | 160gf |
| T4BJA20-Q | 200gf |
| T4BJA26-Q | 260gf |

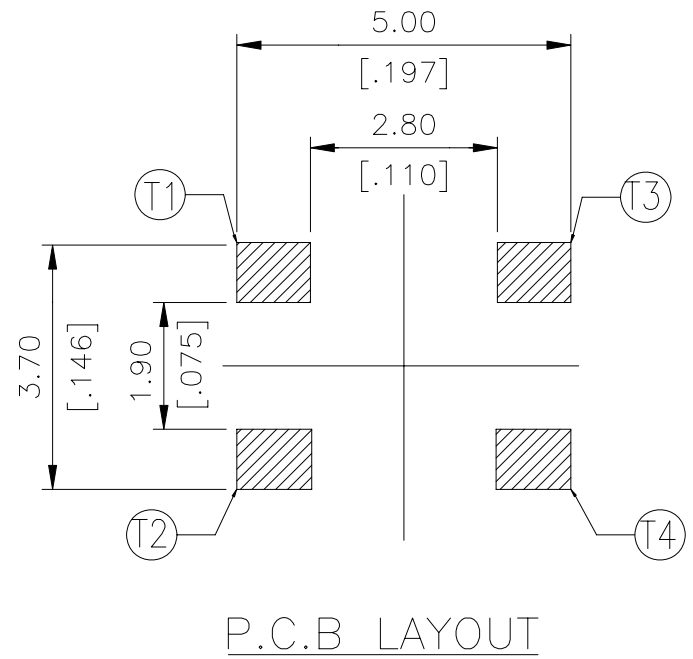

**T4BJB**

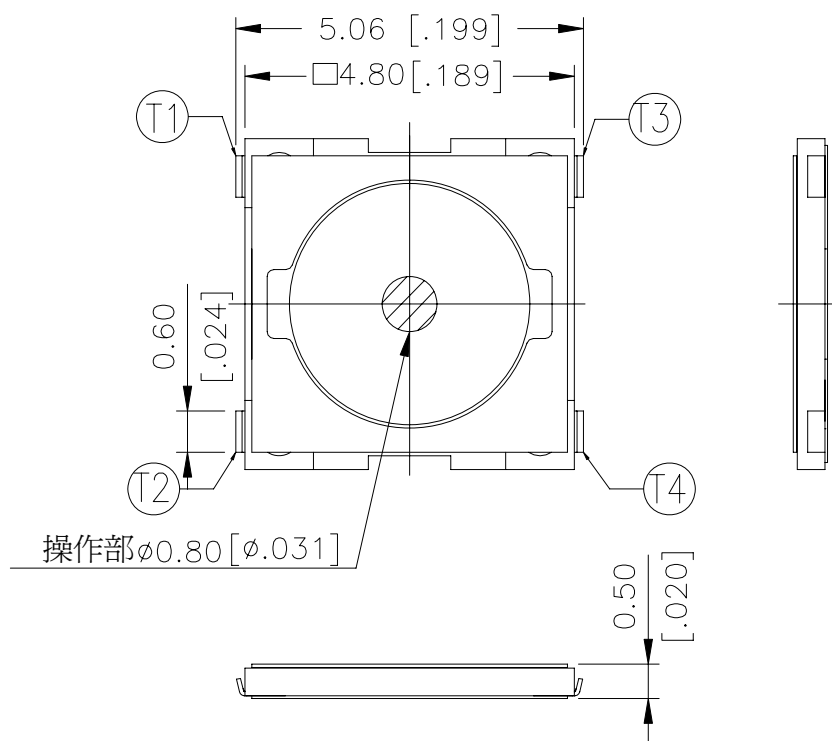

| PART NO   | OF    |
|-----------|-------|
| T4BJB10-Q | 100gf |
| T4BJB16-Q | 160gf |
| T4BJB20-Q | 200gf |
| T4BJB26-Q | 260gf |

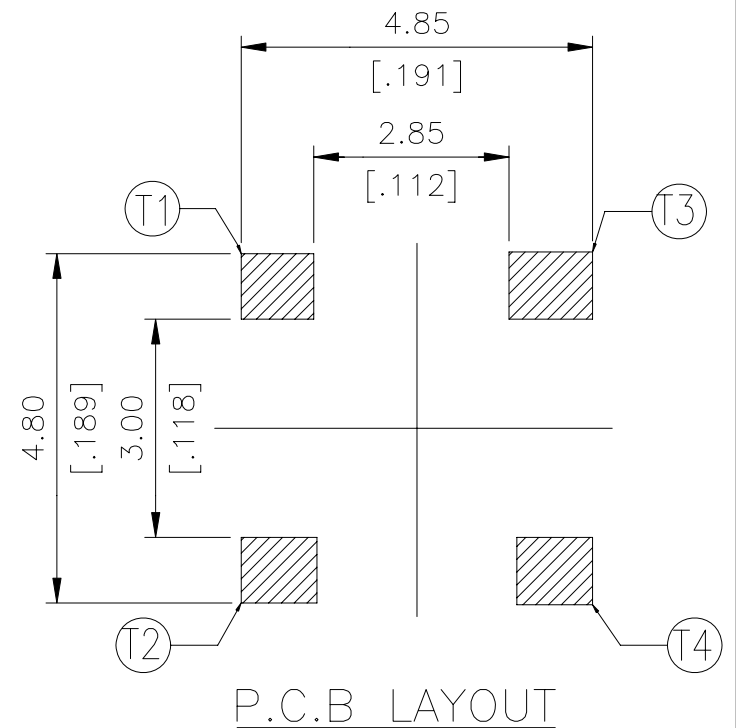

## HOW TO ORDER

T 4 B J □ - □ □ - Q - □

Package :  
T/R = Tape & Reel

Halogen Free

Operating Force :

10 = 100gf

16 = 160gf

20 = 200gf

26 = 260gf

The Middle OF Pitch :

A = 2.8mm

B = 3.7mm

J Terminal SMT Type

Tact Switch 4.8x4.8

## SPECIFICATION

### △MECHANICAL

Operation Force : 100±50gf

160±50gf

200±50gf

260±50gf

Stroke : 0.2±0.1mm

Operation Temperature Range : -40°C to +80°C

Storage Temperature Range : -40°C to +80°C

### △ELECTRICAL

Electrical Life : 200,000 cycles for 100gf、160gf.

100,000 cycles for 200gf、260gf.

50 mA, 12 VDC

Contact Resistance : 100 mΩ max.

Insulation Resistance : 100MΩ min. at 100 VDC

Dielectric Strength: 100 VAC/1 minute

Contact Arrangement : 1 pole 1throw

## MATERIAL

△BASE : UL 94V-0 LCP High-Temp Thermoplastic.

Color : Black

△CONTACT : Stainless steel with silver cladding.

△TERMINAL : Phosphor bronze with silver cladding.

△TAPE : Kapton.

## SOLDERING PROCESS

△HAND SOLDERING : Use a soldering iron of 30 watts, controlled at 350°C approximately 5 seconds while applying solder.

△REFLOW SOLDERING : Vapor phase & reflow soldering can be applied.

△Temperature Profile :

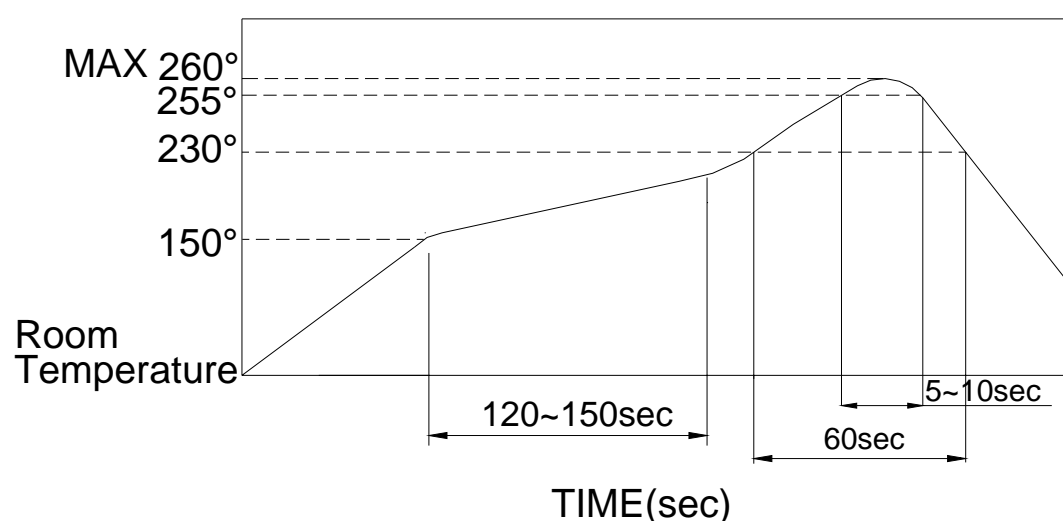

# PACKING

| Part Number | Number Per Tube | Number Per Reel |
|-------------|-----------------|-----------------|
| T4BJ        | -               | 8000            |

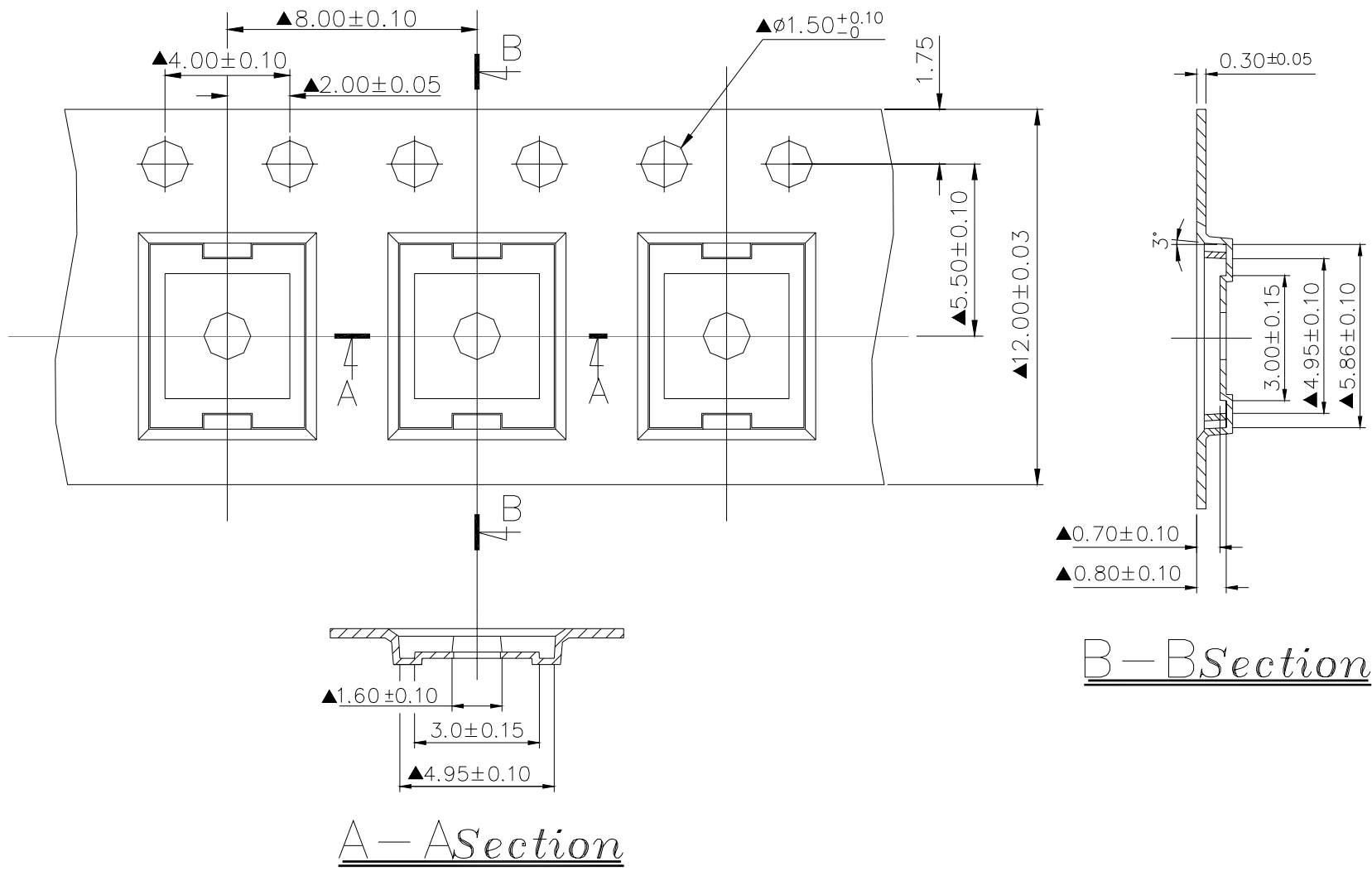

General Tolerance :  $\pm 0.1$ mm