

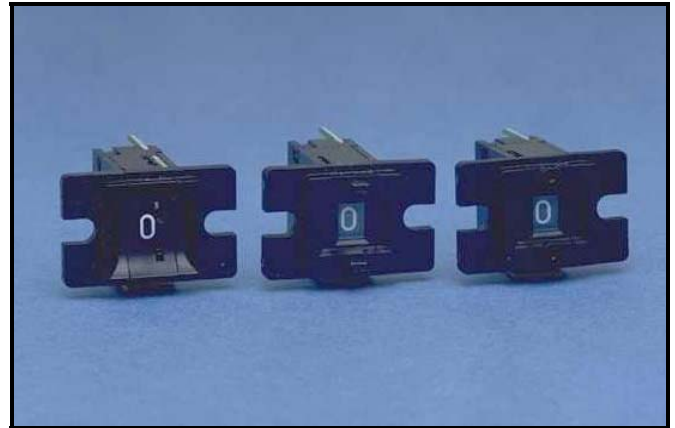

# EECO® 1000 SERIES THUMBWHEEL SWITCHES

*If a front panel, pushwheel switch in the smallest possible package is part of your design requirements, EECO's 1000 Series is the ideal solution*

The **1000 Series** is the smallest rear-mount pushwheel digital switch available today. Actuation methods include thumbwheel, push-set and pen-set models. The pen-set version eliminates the possibility of accidental setting changes, and is ideal for critical "set and forget" applications. The **1000 Series** is offered in either binary or decimal code versions, and optional features include stop pins, and provision for diode installation. The **1000 Series** is backed by EECO's one-year warranty.



## SPECIFICATIONS

### MECHANICAL

|                            |                         |
|----------------------------|-------------------------|
| No. of Switching Positions | 10                      |
| Life                       | Minimum 300,000 Detents |
| Actuation Force            | 10.5 Oz.                |
| Weight                     | 0.11 Oz.                |

### ELECTRICAL

|                                   |                            |
|-----------------------------------|----------------------------|
| Maximum Rated Load, Non-Switching | 500 mA Per Common Terminal |
| Maximum Rated Load, Switching     | 100 mA At 50 VAC or 28 VDC |
| Contact Resistance (Initial)      | 200 mΩ Maximum             |
| Insulation Resistance             | 10 MΩ Minimum              |
| Dielectric Withstanding Voltage   | 500 VAC For 1 Minute       |

### ENVIRONMENTAL

|                       |                                |
|-----------------------|--------------------------------|
| Operating Temperature | -20°C To +60°C                 |
| Storage Temperature   | -40°C To +80°C                 |
| Vibration             | 50 m/Sec <sup>2</sup> (5-55Hz) |
| Shock                 | 100 m/Sec <sup>2</sup> (10G)   |
| Seal                  | Dust Resistant                 |

### MATERIALS

|               |  |
|---------------|--|
| Plastic       | Polyacetal Resin                       |
| Circuit Board |  |
| Base Material | Glass Epoxy                            |
| Plating       | Gold Over Nickel Plating               |
| Termination   | Plated Through Holes                   |
| Contacts      | Copper Alloy, Gold Over Nickel Plating |

## RoHS COMPLIANCE

EECO Switch is fully committed to complying with the European Lead-Free and RoHS directives. The 1000 Series is Lead Free and RoHS compliant.



OUTLINE DIMENSIONS

R E A R M O U N T

1000 THUMBWHEEL

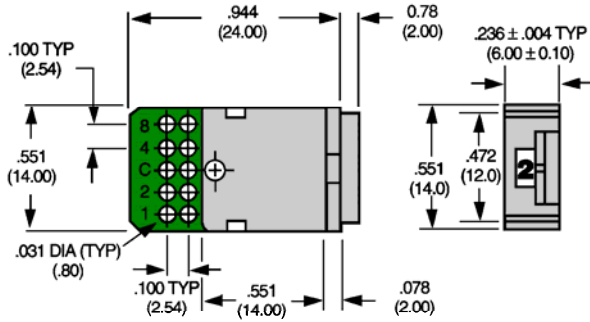

- NOTES;
1. Character Height is .126 (3.2)
  2. ( ) dimensions in mm.
  3. Tolerance on all dimensions .010 unless otherwise specified

1001 PUSH-SET

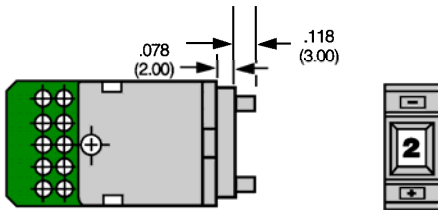

DECIMAL CODE MODELS

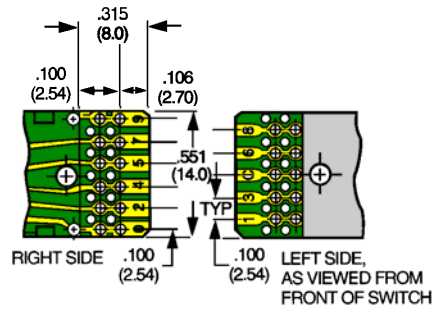

1002 PEN-SET

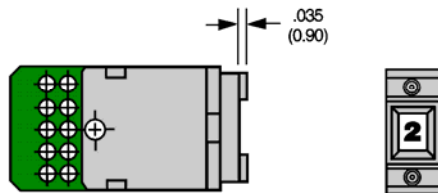

PCB WITH DIODE PROVISION

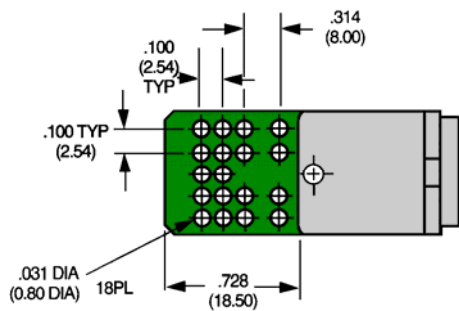

"F" OPTION PIN SPACING

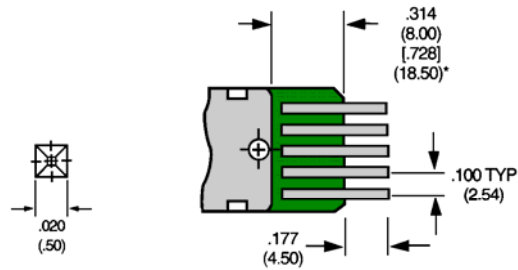

"F" Option Not Available On Decimal Code Models.

MOUNTING DIMENSIONS

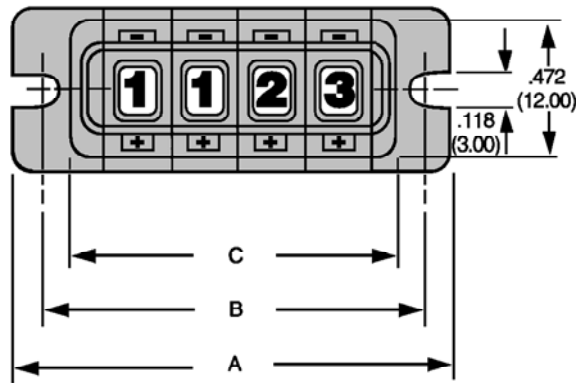

PANEL CUT-OUT

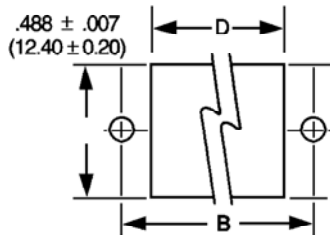

| No. Of Switches | A      | B      | C      | D      |
|-----------------|--------|--------|--------|--------|
| 1               | 0.866  | 0.669  | 0.472  | 0.480  |
|                 | (22.0) | (17.0) | (12.0) | (12.2) |
| 2               | 1.102  | 0.906  | 0.709  | 0.717  |
|                 | (28.0) | (23.0) | (18.0) | (18.2) |
| 3               | 1.339  | 1.142  | 0.945  | 0.953  |
|                 | (34.0) | (29.0) | (24.0) | (24.2) |
| 4               | 1.575  | 1.378  | 1.181  | 1.189  |
|                 | (40.0) | (35.0) | (30.0) | (30.2) |
| 5               | 1.811  | 1.614  | 1.417  | 1.425  |
|                 | (46.0) | (41.0) | (36.0) | (36.2) |
| 6               | 2.047  | 1.850  | 1.654  | 1.661  |
|                 | (52.0) | (47.0) | (42.0) | (42.2) |
| 7               | 2.283  | 2.087  | 1.890  | 1.898  |
|                 | (58.0) | (53.0) | (48.0) | (48.2) |
| 8               | 2.520  | 2.323  | 2.126  | 2.134  |
|                 | (64.0) | (59.0) | (54.0) | (54.2) |
| 9               | 2.756  | 2.559  | 2.362  | 2.370  |
|                 | (70.0) | (65.0) | (60.0) | (60.2) |
| 10              | 2.992  | 2.795  | 2.598  | 2.606  |
|                 | (76.0) | (71.0) | (66.0) | (66.2) |

Metric dimensions in ( )  
 "D" Dimensions ±.007 (0.2)

OUTLINE DIMENSIONS- Spacers And Endpieces

**END PIECES**  
**E10SJ (1000 THUMBWHEEL)**

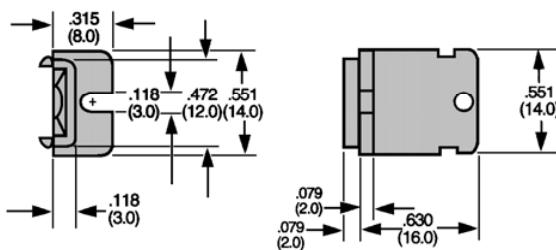

**SPACERS**  
**S10SJ (1000 THUMBWHEEL)**

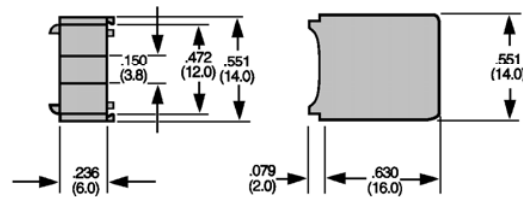

**E30SJ (1001, 1002 PUSHWHEEL)**

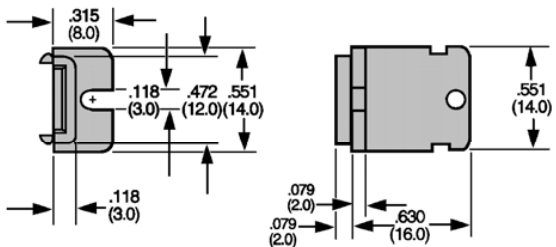

**S30SJ (1001, 1002 PUSHWHEEL)**

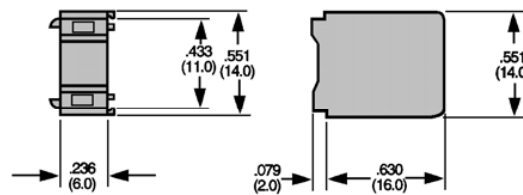

NOTE: Endpieces sold as pairs



# 1000 SERIES STANDARD SWITCHES

| THUMBWHEEL | PUSH-SET | PEN-SET | CODE DESCRIPTION             | NO. OF POSITIONS | TRUTH TABLE |
|------------|----------|---------|------------------------------|------------------|-------------|
| 100001J    | 100101J  | 100201J | 1 Pole Decimal               | 10               | A02         |
| 100002J    | 100102J  | 100202J | 1 Pole BCD                   | 10               | B02         |
| 100052J    | 100152J  | 100252J | 1 Pole BCD w/Diode Provision | 10               | B02         |

**A02**

DECIMAL 1 Pole 10 Position

|                  |                           |   |   |   |   |   |   |   |   |   |
|------------------|---------------------------|---|---|---|---|---|---|---|---|---|
| D<br>I<br>A<br>L | Common (C) Connected To ● |   |   |   |   |   |   |   |   |   |
|                  | 0                         | 1 | 2 | 3 | 4 | 5 | 6 | 7 | 8 | 9 |
| 0                | ●                         |   |   |   |   |   |   |   |   |   |
| 1                |                           | ● |   |   |   |   |   |   |   |   |
| 2                |                           |   | ● |   |   |   |   |   |   |   |
| 3                |                           |   |   | ● |   |   |   |   |   |   |
| 4                |                           |   |   |   | ● |   |   |   |   |   |
| 5                |                           |   |   |   |   | ● |   |   |   |   |
| 6                |                           |   |   |   |   |   | ● |   |   |   |
| 7                |                           |   |   |   |   |   |   | ● |   |   |
| 8                |                           |   |   |   |   |   |   |   | ● |   |
| 9                |                           |   |   |   |   |   |   |   |   | ● |

**B02**

BCD 1 Pole 10 Position

|                  |                           |   |   |   |
|------------------|---------------------------|---|---|---|
| D<br>I<br>A<br>L | Common (C) Connected To ● |   |   |   |
|                  | 1                         | 2 | 4 | 8 |
| 0                |                           |   |   |   |
| 1                | ●                         |   |   |   |
| 2                |                           | ● |   |   |
| 3                | ●                         | ● |   |   |
| 4                |                           |   | ● |   |
| 5                | ●                         |   | ● |   |
| 6                |                           | ● | ● |   |
| 7                | ●                         | ● | ● |   |
| 8                |                           |   |   | ● |
| 9                | ●                         |   |   | ● |

### AVAILABLE OPTIONS

- D** Decimal Point
- C** Stop Pins (Factory Installed Only)

### HARDWARE KITS AND ACCESSORIES

- 10SJ-X** Hardware Kit: Nuts, Rods (Thumbwheel)
- 30SJ-X** Hardware Kit: Nuts, Rods (Push Button)
- E10SJ** Endpieces (Thumbwheel, Pairs)
- E30SJ** Endpieces (Push Button, Pairs)
- S10SJ** Spacer (Thumbwheel)
- S21SJ** Spacer (Push Button)

**Note:** Replace "X" With Number of Stations Required When Ordering Hardware Kits

### ORDERING EXAMPLE

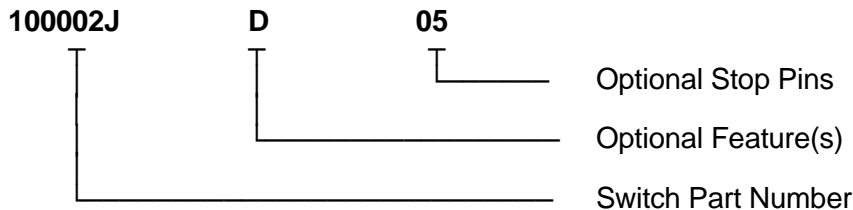

**NOTE:** 1000 Series Switches And Endpieces Sold Unassembled



# EECO®

## 1100 SERIES

# THUMBWHEEL SWITCHES

*EECO's 1100 Series switches offer four different actuator styles in a compact, snap-in design.*

The *1100 Series* snaps in from the front of the panel, making installation fast and easy. The *1100 Series* is offered in four different acuator styles, allowing the engineer the greatest design flexibility. Actuator styles include standard thumbwheel, push-set, pen-set and lock-set models. The pen-set and lock-set models eliminate accidental setting changes and are an ideal choice for critical "set and forget" applications. The *1100 Series* is offered in either binary or decimal code versions, and optional features include stop pins, and provision for diode installation. The *1100 Series* is backed by EECO's one-year warranty.

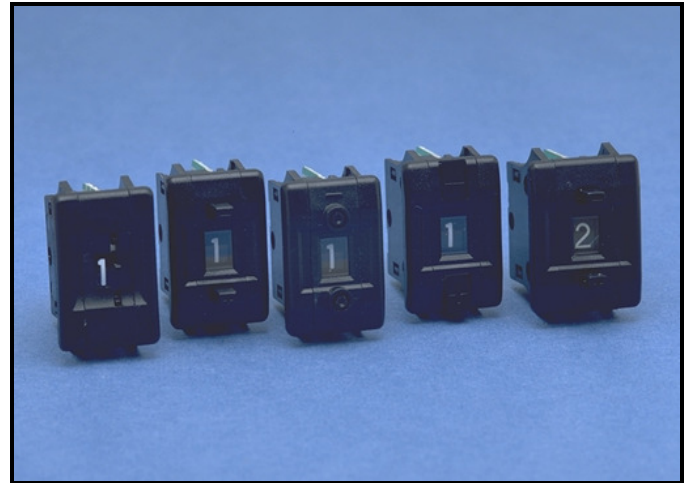

### SPECIFICATIONS

#### MECHANICAL

|                            |                         |
|----------------------------|-------------------------|
| No. of Switching Positions | 10                      |
| Life                       | Minimum 300,000 Detents |
| Actuation Force            | 10.5 Oz.                |
| Weight                     | 0.11 Oz.                |

#### ELECTRICAL

|                                   |                            |
|-----------------------------------|----------------------------|
| Maximum Rated Load, Non-Switching | 500 mA Per Common Terminal |
| Maximum Rated Load, Switching     | 100 mA At 50 VAC or 28 VDC |
| Contact Resistance (Initial)      | 200 mΩ Maximum             |
| Insulation Resistance             | 10 MΩ Minimum              |
| Dielectric Withstanding Voltage   | 500 VAC For 1 Minute       |

#### ENVIRONMENTAL

|                       |                                |
|-----------------------|--------------------------------|
| Operating Temperature | -20°C To +60°C                 |
| Storage Temperature   | -40°C To +80°C                 |
| Vibration             | 50 m/Sec <sup>2</sup> (5-55Hz) |
| Shock                 | 100 m/Sec <sup>2</sup> (10G)   |
| Seal                  | Dust Resistant                 |

#### MATERIALS

|               |  |
|---------------|--|
| Plastic       | Polyacetal Resin                       |
| Circuit Board |  |
| Base Material | Glass Epoxy                            |
| Plating       | Gold Over Nickel Plating               |
| Termination   | Plated Through Holes                   |
| Contacts      | Copper Alloy, Gold Over Nickel Plating |

### RoHS COMPLIANCE

EECO Switch is fully committed to complying with the European Lead-Free and RoHS directives. The 1100 Series is Lead Free and RoHS compliant.



# OUTLINE DIMENSIONS

## FRONT MOUNT

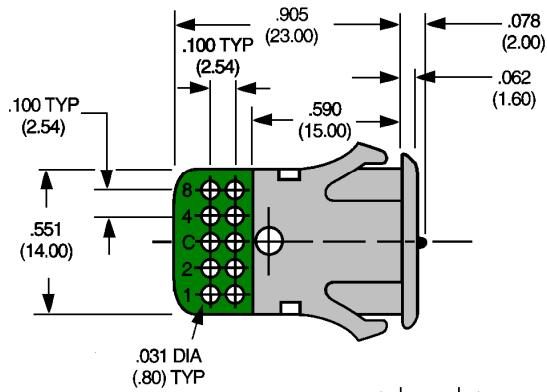

**1100 THUMBWHEEL**

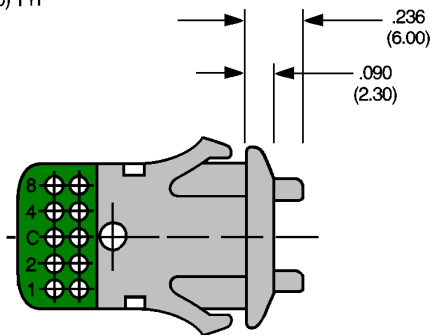
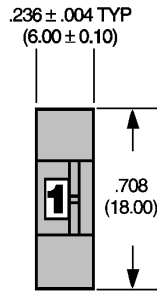

**1101 PUSH-SET**

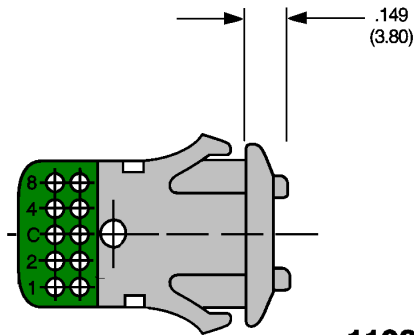

**1102 PEN-SET**

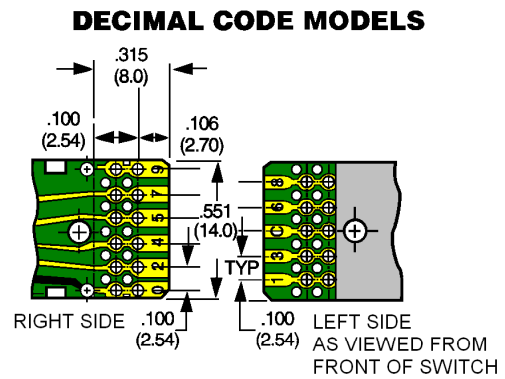

## DECIMAL CODE MODELS

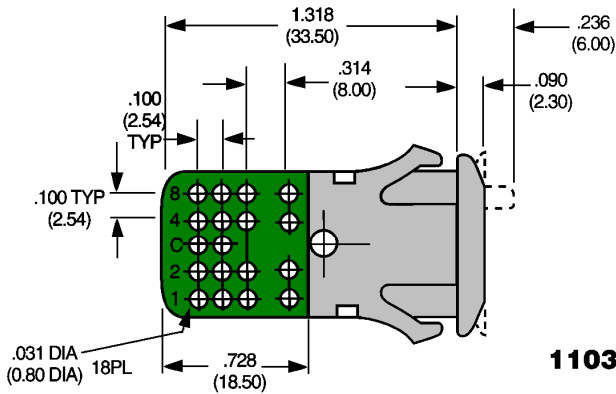

**1103 LOCK-SET**

## PCB WITH DIODE PROVISION

### NOTES

1. Character height is .126 (3.2)
2. ( ) dimensions in mm.
3. Tolerance on all dimensions 0.010 unless otherwise specified
4. Dimensions typical for all versions.

**MOUNTING DIMENSIONS**

**1100 FRONT MOUNT SERIES**

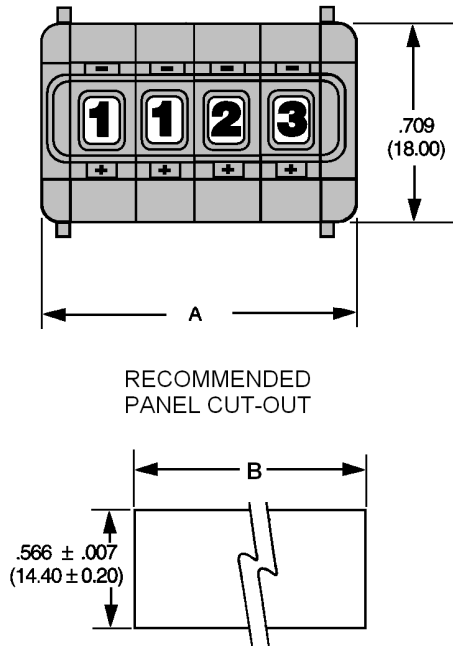

| No. Of Switches | A              | B              |
|-----------------|----------------|----------------|
| 1               | 0.47<br>(12.0) | 0.32<br>(8.2)  |
| 2               | 0.71<br>(18.0) | 0.56<br>(14.2) |
| 3               | 0.94<br>(24.0) | 0.80<br>(20.2) |
| 4               | 1.18<br>(30.0) | 1.03<br>(26.2) |
| 5               | 1.42<br>(36.0) | 1.27<br>(32.2) |
| 6               | 1.65<br>(42.0) | 1.50<br>(38.2) |
| 7               | 1.89<br>(48.0) | 1.74<br>(44.2) |
| 8               | 2.13<br>(54.0) | .98<br>(50.2)  |
| 9               | 2.36<br>(60.0) | 2.21<br>(56.2) |
| 10              | 2.60<br>(66.0) | 2.45<br>(62.2) |

**OUTLINE DIMENSIONS - Spacers And Endpieces**

**ENDPIECES**

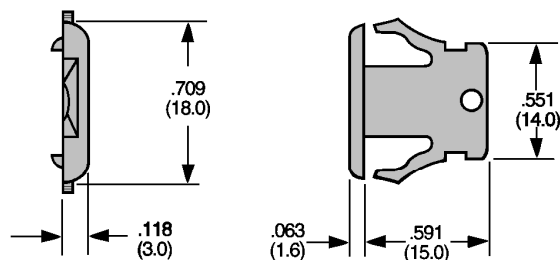

**E11SJ (THUMBWHEEL)**

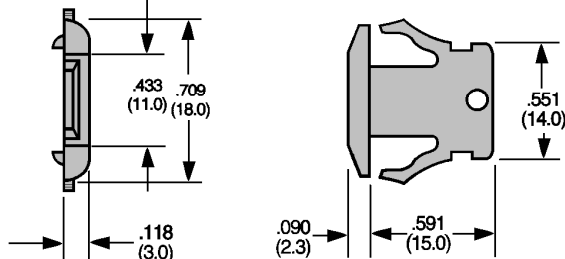

**E21SJ (1101, 1102, 1103 PUSHWHEEL)**

**SPACERS**

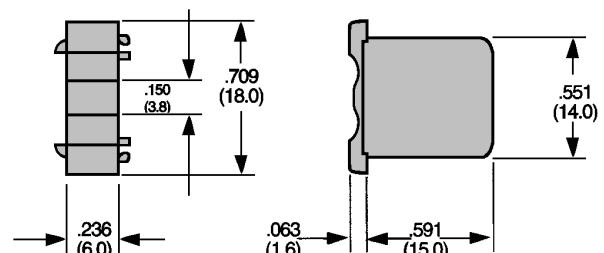

**S11SJ (1100 THUMBWHEEL)**

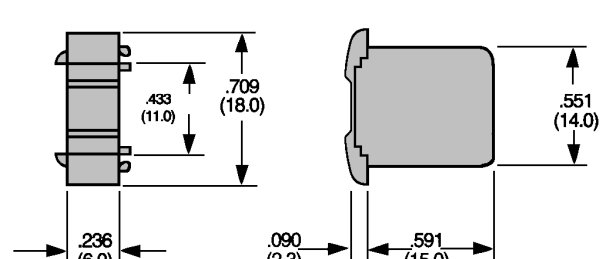

**S21SJ (1101, 1102, 1103 PUSHWHEEL)**



# 1100 SERIES STANDARD SWITCHES

| THUMBWHEEL | PUSH-SET | PEN-SET | LOCK-SET | CODE DESCRIPTION             | NO. OF POSITIONS | TRUTH TABLE |
|------------|----------|---------|----------|------------------------------|------------------|-------------|
| 110001J    | 110101J  | 110201J | 110301J  | 1 Pole Decimal               | 10               | A02         |
| 110002J    | 110102J  | 110202J | 110302J  | 1 Pole BCD                   | 10               | B02         |
| 110052J    | 110152J  | 110252J | 110352J  | 1 Pole BCD w/Diode Provision | 10               | B02         |

**A02**  
DECIMAL 1 Pole 10 Position

|                  |                           |   |   |   |   |   |   |   |   |   |
|------------------|---------------------------|---|---|---|---|---|---|---|---|---|
| D<br>I<br>A<br>L | Common (C) Connected To ● |   |   |   |   |   |   |   |   |   |
|                  | 0                         | 1 | 2 | 3 | 4 | 5 | 6 | 7 | 8 | 9 |
| 0                | ●                         |   |   |   |   |   |   |   |   |   |
| 1                |                           | ● |   |   |   |   |   |   |   |   |
| 2                |                           |   | ● |   |   |   |   |   |   |   |
| 3                |                           |   |   | ● |   |   |   |   |   |   |
| 4                |                           |   |   |   | ● |   |   |   |   |   |
| 5                |                           |   |   |   |   | ● |   |   |   |   |
| 6                |                           |   |   |   |   |   | ● |   |   |   |
| 7                |                           |   |   |   |   |   |   | ● |   |   |
| 8                |                           |   |   |   |   |   |   |   | ● |   |
| 9                |                           |   |   |   |   |   |   |   |   | ● |

**B02**  
BCD 1 Pole 10 Position

|                  |                           |   |   |   |
|------------------|---------------------------|---|---|---|
| D<br>I<br>A<br>L | Common (C) Connected To ● |   |   |   |
|                  | 1                         | 2 | 4 | 8 |
| 0                |                           |   |   |   |
| 1                | ●                         |   |   |   |
| 2                |                           | ● |   |   |
| 3                | ●                         | ● |   |   |
| 4                |                           |   | ● |   |
| 5                | ●                         |   | ● |   |
| 6                |                           | ● | ● |   |
| 7                | ●                         | ● | ● |   |
| 8                |                           |   |   | ● |
| 9                | ●                         |   |   | ● |

### AVAILABLE OPTIONS

**D** Decimal Point  
Stop Pins (Factory Installed Only)

### HARDWARE KITS AND ACCESSORIES

**E11SJ** Endpieces (Thumbwheel, Pairs)  
**E21SJ** Endpieces (Push Button, Pairs)

**S11SJ** Spacer (Thumbwheel)  
**S21SJ** Spacer (Push Button)

**Note: Replace "X" With Number of Stations Required When Ordering Hardware Kits**

### ORDERING EXAMPLE

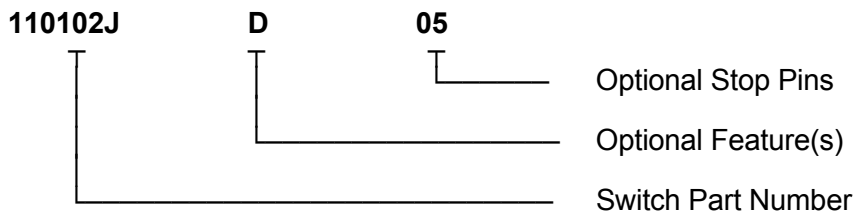

**NOTE:** 1100 Series Switches And Endpieces Sold Unassembled



# EECO® 1400 SERIES THUMBWHEEL SWITCHES

*EECO's 1400 Series switches feature snap-in front mounting in a large, easy to use package size.*

The *1400 Series* snaps in from the front of the panel, allowing the user to create multi-switch assemblies quickly without the need for additional mounting hardware. The *1400 Series* is offered in a choice of thumbwheel, push-set and lock-set actuator styles. The lock-set model features hinged actuators which fold flush with the front of the switch, eliminating accidental setting changes, and are an ideal choice for critical "set and forget" applications. The *1400 Series* is available as either a 10 position decimal code switch or as a 10 or 16 position binary coded version. Optional features include stop pins, and provision for diode installation. The *1400 Series* is backed by EECO's one-year warranty.



## SPECIFICATIONS

### MECHANICAL

|                            |                           |
|----------------------------|---------------------------|
| No. of Switching Positions | 10 and 16                 |
| Life                       | Minimum 1,000,000 Detents |
| Actuation Force            | 14 Oz.                    |
| Weight                     | 0.16 Oz.                  |

### ELECTRICAL

|                                   |                            |
|-----------------------------------|----------------------------|
| Maximum Rated Load, Non-Switching | 1.0 A Per Common Terminal  |
| Maximum Rated Load, Switching     | 100 mA At 50 VAC or 28 VDC |
| Contact Resistance (Initial)      | 200 mΩ Maximum             |
| Insulation Resistance             | 10 MΩ Minimum              |
| Dielectric Withstanding Voltage   | 500 VAC For 1 Minute       |

### ENVIRONMENTAL

|                       |                                |
|-----------------------|--------------------------------|
| Operating Temperature | -20°C To +60°C                 |
| Storage Temperature   | -40°C To +80°C                 |
| Vibration             | 50 m/Sec <sup>2</sup> (5-55Hz) |
| Shock                 | 100 m/Sec <sup>2</sup> (10G)   |
| Seal                  | Dust Resistant                 |

### MATERIALS

|               |  |
|---------------|--|
| Plastic       | Polyacetal Resin                       |
| Circuit Board |  |
| Base Material | Glass Epoxy                            |
| Plating       | Gold Over Nickel Plating               |
| Termination   | Plated Through Holes                   |
| Contacts      | Copper Alloy, Gold Over Nickel Plating |

## RoHS COMPLIANCE

EECO Switch is fully committed to complying with the European Lead-Free and RoHS directives. The 1400 Series is Lead Free and RoHS compliant.



## MOUNTING DIMENSIONS

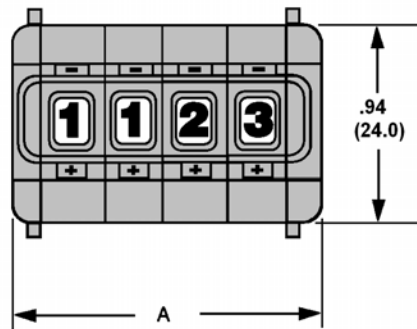

RECOMMENDED PANEL CUT OUT

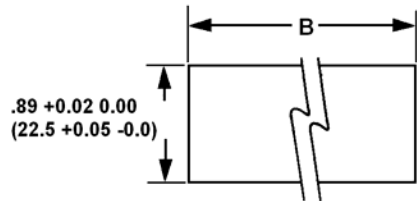

PANEL THICKNESS 0.031 TO 0.118 (0.08 TO 3.0)

| No. Of Switches | A              | B              |
|-----------------|----------------|----------------|
| 1               | 0.63<br>(16.0) | 0.45<br>(11.5) |
| 2               | 0.94<br>(24.0) | 0.77<br>(19.5) |
| 3               | 1.26<br>(32.0) | 1.08<br>(27.5) |
| 4               | 1.57<br>(40.0) | 1.40<br>(35.5) |
| 5               | 1.89<br>(48.0) | 1.71<br>(43.5) |
| 6               | 2.20<br>(56.0) | 2.03<br>(51.5) |
| 7               | 2.52<br>(64.0) | 2.34<br>(59.5) |
| 8               | 2.83<br>(72.0) | 2.66<br>(67.5) |
| 9               | 3.15<br>(80.0) | 2.97<br>(75.5) |
| 10              | 3.46<br>(88.0) | 3.29<br>(83.5) |

## OUTLINE DIMENSIONS - Spacers And Endpieces

**END PIECES (PREFIX "E")**  
**E14SJ (1400 THUMBWHEEL)**

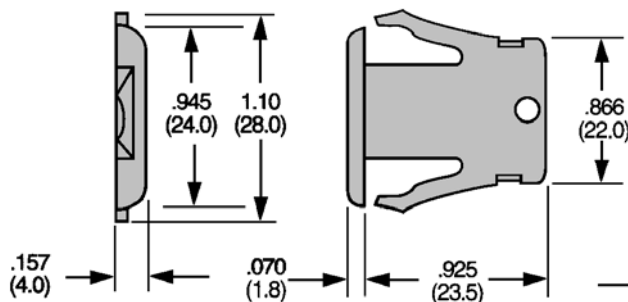

**SPACERS (PREFIX "S")**  
**S14SJ (1400 THUMBWHEEL)**

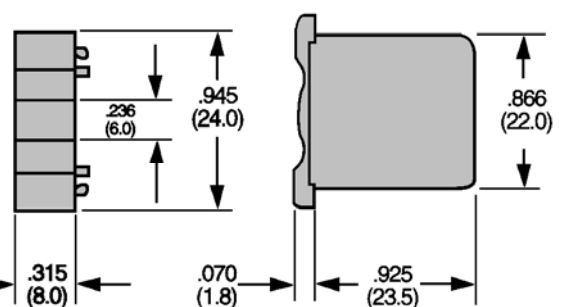

**E13 SJ (1401, 1403 PUSHWHEEL)**

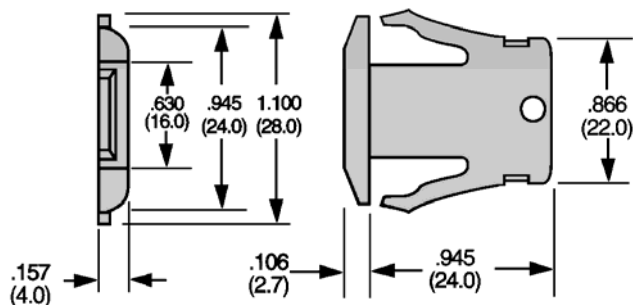

**S24SJ (1401, 1403 PUSHWHEEL)**

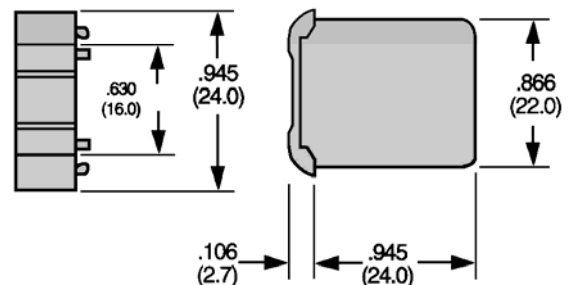



# 1400 Series

## 1400 STANDARD MODELS

| THUMBWHEEL | PUSH-SET | LOCK-SET | CODE DESCRIPTION                     | NO. OF POSITIONS | TRUTH TABLE |
|------------|----------|----------|--------------------------------------|------------------|-------------|
| 140001J    | 140101J  | 140301J  | 1 Pole Decimal                       | 10               | A02         |
| 140002J    | 140102J  | 140302J  | 1 Pole BCD                           | 10               | B02         |
| 140012J    | 140012J  | 140312J  | 1 Pole BCD Complement                | 10               | C12         |
| 140052J    | 140152J  | 140352J  | 1 Pole BCD w/Diode Provision         | 10               | B02         |
|            | 140134J  | 140334J  | 1 Pole Hexadecimal                   | 16               | B07         |
|            | 140184J  | 140384J  | 1 Pole Hexadecimal w/Diode Provision | 16               | B07         |

## TRUTH TABLES

| A02<br>DECIMAL 1 Pole 10 Position |   |   |   |   |   |   |   |   |   | B02<br>BCD 1 Pole 10 Position     |   |   |   |   | B07<br>HEXADECIMAL 1 Pole 16 Position |   |   |   |   | C12<br>BCD Complement 1 Pole 10 Position |   |   |   |   |   |
|-----------------------------------|---|---|---|---|---|---|---|---|---|-----------------------------------|---|---|---|---|---------------------------------------|---|---|---|---|--|---|---|---|---|---|
| D I A L Common (C) Connected To ● |   |   |   |   |   |   |   |   |   | D I A L Common (C) Connected To ● |   |   |   |   | D I A L Common (C) Connected To ●     |   |   |   |   | D I A L Common (C) Connected To ●        |   |   |   |   |   |
| L                                 | 0 | 1 | 2 | 3 | 4 | 5 | 6 | 7 | 8 | 9                                 | L | 1 | 2 | 4 | 8                                     | L | 1 | 2 | 4 | 8  | L | 1 | 2 | 4 | 8 |
| 0                                 | ● |   |   |   |   |   |   |   |   |                                   | 0 |   |   |   |                                       | 0 |   |   |   |  | 0 | ● | ● | ● | ● |
| 1                                 |   | ● |   |   |   |   |   |   |   |                                   | 1 | ● |   |   |                                       | 1 | ● |   |   |  | 1 |   | ● | ● | ● |
| 2                                 |   |   | ● |   |   |   |   |   |   |                                   | 2 |   | ● |   |                                       | 2 |   | ● |   |  | 2 | ● |   | ● | ● |
| 3                                 |   |   |   | ● |   |   |   |   |   |                                   | 3 | ● | ● |   |                                       | 3 | ● | ● |   |  | 3 |   |   | ● | ● |
| 4                                 |   |   |   |   | ● |   |   |   |   |                                   | 4 |   |   | ● |                                       | 4 |   |   | ● |  | 4 | ● | ● |   | ● |
| 5                                 |   |   |   |   |   | ● |   |   |   |                                   | 5 | ● |   | ● |                                       | 5 | ● |   | ● |  | 5 |   | ● |   | ● |
| 6                                 |   |   |   |   |   |   | ● |   |   |                                   | 6 |   | ● | ● |                                       | 6 |   | ● | ● |  | 6 | ● |   |   | ● |
| 7                                 |   |   |   |   |   |   |   | ● |   |                                   | 7 | ● | ● | ● |                                       | 7 | ● | ● | ● |  | 7 |   |   |   | ● |
| 8                                 |   |   |   |   |   |   |   |   | ● |                                   | 8 |   |   |   | ●                                     | 8 |   |   |   | ●  | 8 | ● | ● | ● |   |
| 9                                 |   |   |   |   |   |   |   |   |   | ●                                 | 9 | ● |   |   | ●                                     | 9 | ● |   |   | ●  | 9 |   | ● | ● |   |
|                                   |   |   |   |   |   |   |   |   |   |                                   |   |   |   |   |                                       | A |   | ● |   | ●  |   |   |   |   |   |
|                                   |   |   |   |   |   |   |   |   |   |                                   |   |   |   |   |                                       | B | ● | ● |   | ●  |   |   |   |   |   |
|                                   |   |   |   |   |   |   |   |   |   |                                   |   |   |   |   |                                       | C |   |   | ● | ●  |   |   |   |   |   |
|                                   |   |   |   |   |   |   |   |   |   |                                   |   |   |   |   |                                       | D | ● |   | ● | ●  |   |   |   |   |   |
|                                   |   |   |   |   |   |   |   |   |   |                                   |   |   |   |   |                                       | E |   | ● | ● | ●  |   |   |   |   |   |
|                                   |   |   |   |   |   |   |   |   |   |                                   |   |   |   |   |                                       | F | ● | ● | ● | ●  |   |   |   |   |   |

### AVAILABLE OPTIONS

**D** Decimal Point  
Stop Pins (Factory Installed Only)

**NOTE: 1400 Series Switches Sold Unassembled**

### HARDWARE KITS AND ACCESSORIES

**E13SJ** Endpieces (1400 Push Button, Pairs)  
**E14SJ** Endpieces (1400 Thumbwheel, Pairs )  
**S14SJ** Spacer (1400 Thumbwheel)  
**S24SJ** Spacer (1400 Push Button)

### ORDERING EXAMPLE

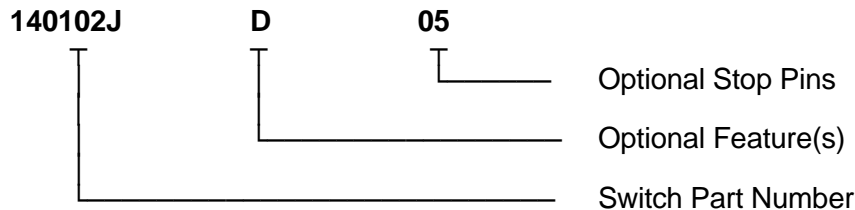



# EECO®

## 1800 SERIES THUMBWHEEL SWITCHES

**LEAD-FREE!**

*EECO's 1800 Series features large, easy to read characters and a snap-in mounting design.*

The *1800 Series* is a slim .315" (8 MM) wide to conserve front panel space. The *1800 Series* is offered in the most popular binary and decimal output codes for design flexibility. Other options include F-pins for attaching an accessory PC board, stop pins, and provision for diode installation. The *1800 Series* offers superior performance at a very economical price. The *1800 Series* is backed by EECO's one-year warranty.



### SPECIFICATIONS

#### MECHANICAL

|                            |   |
|----------------------------|---|
| No. of Switching Positions | 10  |
| Life                       | Minimum 500,000 Detents @ 10 mA, 5 VDC @ 25°C |
| Tangential Operating Force | 4-16 Oz.                                      |
| Weight                     | 0.15 Oz.                                      |

#### ELECTRICAL

|                                   |                             |
|-----------------------------------|-----------------------------|
| Maximum Rated Load, Non-Switching | 1A Per Common Terminal      |
| Maximum Rated Load, Switching     | 100 mA at 28 VDC or VAC     |
| Contact Resistance (Initial)      | 100 mΩ Maximum              |
| (After Life)                      | 200 mΩ Maximum              |
| Insulation Resistance             | 1,000 MΩ Minimum At 100 VDC |
| Dielectric Withstanding Voltage   | 1000 VAC (Peak To Peak)     |

#### ENVIRONMENTAL

|                       |                |
|-----------------------|----------------|
| Operating Temperature | -20°C To +65°C |
| Seal                  | Dust Resistant |

#### MATERIALS

|               |  |
|---------------|--|
| Plastic       | Nylon, Self Extinguishing              |
| Circuit Board |  |
| Base Material | Glass Epoxy                            |
| Plating       | Gold Over Nickel Plating               |
| Termination   | Plated Through Holes                   |
| Contacts      | Copper Alloy, Gold Over Nickel Plating |

### RoHS COMPLIANCE

EECO Switch is fully committed to complying with the European Lead-Free and RoHS directives. The 1800 Series is Lead Free and RoHS compliant.



# OUTLINE DIMENSIONS

## FRONT MOUNT

X = .262 (.665) all models except 180052J (diode provision)  
 which is .695 (1.77)  
 Y = 1.180 (2.99)  
 Z = Consult factory

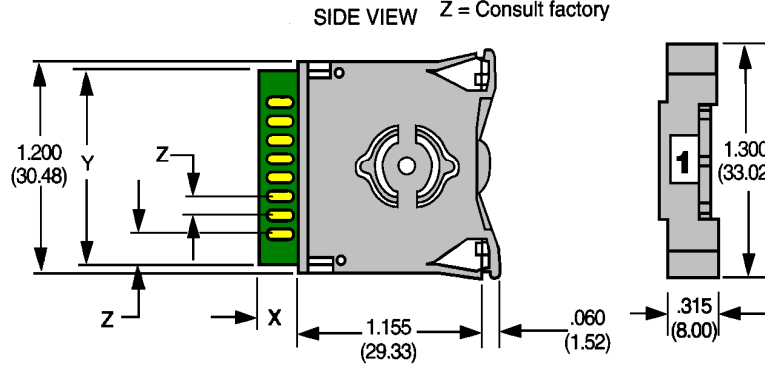

## SPACER - S80SJ

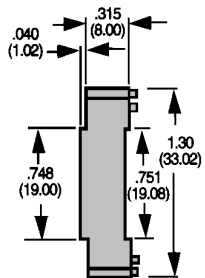
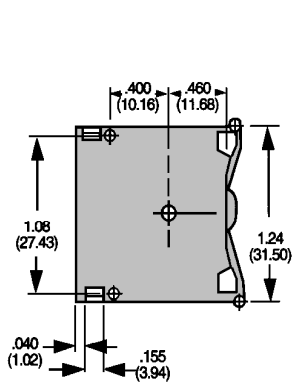

## "F" OPTION PINS

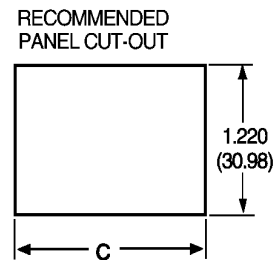
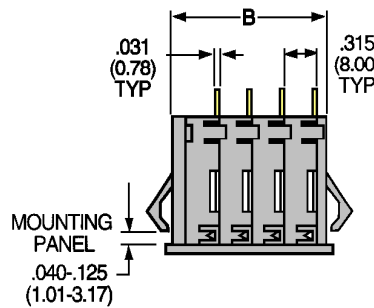
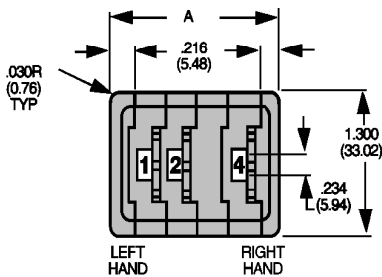
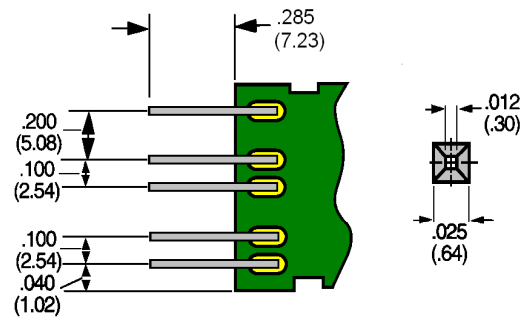

| MOUNTING DIMENSIONS |             |             |             |  |
|---------------------|-------------|-------------|-------------|--|
| No. Of Stations     | Dim A       | Dim B       | Dim C       |  |
| 1                   | 0.75 (19.0) | 0.63 (15.9) | 0.67 (17.0) |  |
| 2                   | 1.06 (27.0) | 0.94 (23.9) | 0.99 (25.0) |  |
| 3                   | 1.38 (35.0) | 1.26 (31.9) | 1.30 (33.0) |  |
| 4                   | 1.69 (43.0) | 1.57 (39.9) | 1.62 (41.0) |  |
| 5                   | 2.01 (51.0) | 1.89 (47.9) | 1.93 (49.0) |  |
| 6                   | 2.32 (59.0) | 2.20 (55.9) | 2.25 (57.0) |  |
| 7                   | 2.64 (67.0) | 2.52 (63.9) | 2.56 (65.0) |  |
| 8                   | 2.95 (75.0) | 2.83 (71.9) | 2.88 (73.0) |  |
| 9                   | 3.27 (83.0) | 3.15 (79.9) | 3.19 (81.0) |  |
| 10                  | 3.58 (91.0) | 3.46 (87.9) | 3.51 (89.0) |  |

Assembly may exhibit expansion of .003" per station before installation, but will compress to recommended panel cutout when installed.

Spacers are counted as switches in this table.

Add .315" (8 mm) per station to each dimension shown for assemblies over 10 stations

Tolerances are :  
 .XXX ± 0.010" .XX ± 0.030"  
 ( ) Metric equivalents in mm



## 1800 SERIES STANDARD MODELS

| PART NUMBER | PART DESCRIPTION             | NO. OF POSITIONS | TRUTH TABLE |
|-------------|------------------------------|------------------|-------------|
| 180001J     | 1 Pole Decimal               | 10               | A02         |
| 180002J     | 1 Pole BCD                   | 10               | B02         |
| 180052J     | 1 Pole BCD w/Diode Provision | 10               | B02         |
| 180006J     | 2 Pole BCD w/Complement      | 10               | C02         |
| 180012J     | 1 Pole BCD Complement Only   | 10               | C12         |
| 180005J     | 2 Pole Repeating 0, 5        | 10               | S01         |
| 180010J     | 2 Pole Repeating 0, 1        | 10               | S01         |
| 180011J     | 2 Pole Repeating + / -       | 10               | S01         |

**A02**

| DECIMAL 1 Pole 10 Position |                           |   |   |   |   |   |   |   |   |   |
|----------------------------|---------------------------|---|---|---|---|---|---|---|---|---|
| DIAL                       | Common (C) Connected To ● |   |   |   |   |   |   |   |   |   |
|                            | 0                         | 1 | 2 | 3 | 4 | 5 | 6 | 7 | 8 | 9 |
| 0                          | ●                         |   |   |   |   |   |   |   |   |   |
| 1                          |                           | ● |   |   |   |   |   |   |   |   |
| 2                          |                           |   | ● |   |   |   |   |   |   |   |
| 3                          |                           |   |   | ● |   |   |   |   |   |   |
| 4                          |                           |   |   |   | ● |   |   |   |   |   |
| 5                          |                           |   |   |   |   | ● |   |   |   |   |
| 6                          |                           |   |   |   |   |   | ● |   |   |   |
| 7                          |                           |   |   |   |   |   |   | ● |   |   |
| 8                          |                           |   |   |   |   |   |   |   | ● |   |
| 9                          |                           |   |   |   |   |   |   |   |   | ● |

**B02**

| BCD 1 Pole 10 Position |                           |   |   |   |
|------------------------|---------------------------|---|---|---|
| DIAL                   | Common (C) Connected To ● |   |   |   |
|                        | 1                         | 2 | 4 | 8 |
| 0                      |                           |   |   |   |
| 1                      | ●                         |   |   |   |
| 2                      |                           | ● |   |   |
| 3                      | ●                         | ● |   |   |
| 4                      |                           |   |   | ● |
| 5                      | ●                         |   |   | ● |
| 6                      |                           | ● | ● |   |
| 7                      | ●                         | ● | ● |   |
| 8                      |                           |   |   | ● |
| 9                      | ●                         |   |   | ● |

**C02**

| BCD w/Complement 1 Pole 10 Position |                           |   |   |   |    |    |    |    |
|-------------------------------------|---------------------------|---|---|---|----|----|----|----|
| DIAL                                | Common (C) Connected To ● |   |   |   |    |    |    |    |
|                                     | 1                         | 2 | 4 | 8 | 1̄ | 2̄ | 4̄ | 8̄ |
| 0                                   |                           |   |   |   | ●  | ●  | ●  | ●  |
| 1                                   | ●                         |   |   |   |    | ●  | ●  | ●  |
| 2                                   |                           | ● |   |   | ●  |    | ●  | ●  |
| 3                                   | ●                         | ● |   |   |    |    | ●  | ●  |
| 4                                   |                           |   | ● |   | ●  | ●  |    | ●  |
| 5                                   | ●                         |   | ● |   |    | ●  |    | ●  |
| 6                                   |                           | ● | ● |   | ●  |    |    | ●  |
| 7                                   | ●                         | ● | ● |   |    |    |    | ●  |
| 8                                   |                           |   |   | ● | ●  | ●  | ●  |    |
| 9                                   | ●                         |   |   | ● |    | ●  | ●  |    |

**C12**

| BCD Complement 1 Pole 10 Position |                           |    |    |    |
|-----------------------------------|---------------------------|----|----|----|
| DIAL                              | Common (C) Connected To ● |    |    |    |
|                                   | 1̄                        | 2̄ | 4̄ | 8̄ |
| 0                                 | ●                         | ●  | ●  | ●  |
| 1                                 |                           | ●  | ●  | ●  |
| 2                                 | ●                         |    | ●  | ●  |
| 3                                 |                           |    | ●  | ●  |
| 4                                 | ●                         | ●  |    | ●  |
| 5                                 |                           | ●  |    | ●  |
| 6                                 | ●                         |    |    | ●  |
| 7                                 |                           |    |    | ●  |
| 8                                 | ●                         | ●  | ●  |    |
| 9                                 |                           | ●  | ●  |    |

**S01**

| A/B Repeating Code Double Pole 10 Position |   |   |                                     |    |    |    |  |
|--|---|---|-------------------------------------|----|----|----|--|
| DIAL                                       |   |   | Common (C1) and (C2) Connected To ● |    |    |    |  |
|  |   |   | C1                                  |    | C2 |    |  |
|  |   |   | A1                                  | B1 | A2 | B2 |  |
| 0  | 0 | + |                                     | ●  |    | ●  |  |
| 1  | 5 | - | ●                                   |    | ●  |    |  |
| 0  | 0 | + |                                     | ●  |    | ●  |  |
| 1  | 5 | - | ●                                   |    | ●  |    |  |
| 0  | 0 | + |                                     | ●  |    | ●  |  |
| 1  | 5 | - | ●                                   |    | ●  |    |  |
| 0  | 0 | + |                                     | ●  |    | ●  |  |
| 1  | 5 | - | ●                                   |    | ●  |    |  |
| 0  | 0 | + |                                     | ●  |    | ●  |  |
| 1  | 5 | - | ●                                   |    | ●  |    |  |



### AVAILABLE OPTIONS

- A** Diodes Installed Anode To Common
  - C** Diodes Installed Cathode To Common
  - D** Decimal Point
  - P** +/- Rotor Marking
  - Stop Pins
- Consult Factory for Custom Rotor Marking, Custom Output Codes and Other Special Requests

### ORDERING EXAMPLE - SWITCH

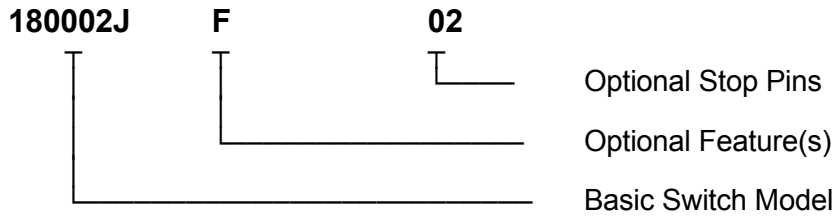

### ORDERING EXAMPLE - ASSEMBLY

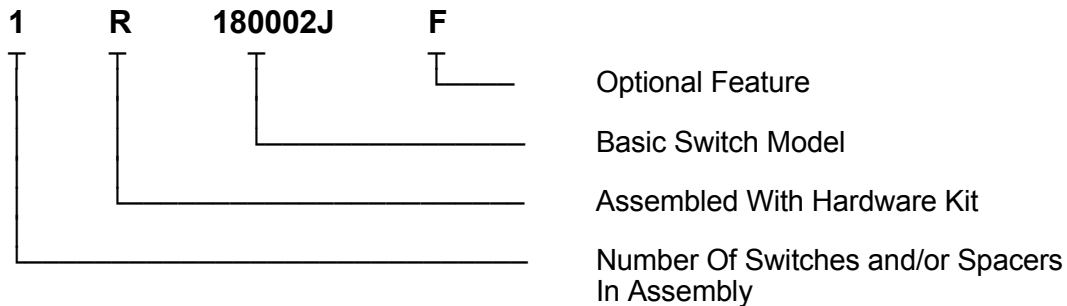

Certain combinations of switches and options may require a special part number. Consult factory for additional ordering information.

### HARDWARE KITS AND ACCESSORIES

- 80SJ-X** Hardware Kit: Endpieces, Speed Nuts, Aluminum Rod (Factory Assembled Only)
  - 81SJ-X** Hardware Kit: Endpieces, Threaded Rod, Nuts and Washers
- Note: Replace "X" With Number of Stations Required When Ordering Separate Hardware Kits.**
- E80SJ** Endpiece, Right (234147-09)
  - E81SJ** Endpiece, Left (234146-09)
  - S80SJ** Spacer (234149-09)



# EECO® 2000 SERIES THUMBWHEEL SWITCHES

*EECO's 2000 Series is ideal for demanding industrial control applications. The large size of the switch makes it easy to operate, even if the operator is wearing gloves.*

The 2000 Series is available with an optional internal O-ring seal for use in harsh environments. The 2000 Series switch is 500" wide and features PCB termination designed to accept a variety of edge connectors, and also allows direct wiring. Other options such as lighted indicators, custom legends, stops and diode provisions make the 2000 Series an excellent choice for heavy-duty industrial control applications demanding high reliability. The 2000 Series is covered by EECO's one-year warranty.



## SPECIFICATIONS

### MECHANICAL

|                            |                           |
|----------------------------|---------------------------|
| No. of Switching Positions | 8, 10, 12, 16             |
| Life                       | Minimum 1,000,000 Detents |
| Tangential Operating Force | 6-18 Oz                   |
| Weight                     | 0.8 Oz.                   |

### ELECTRICAL

|   |   |
|---|---|
| Maximum Electrical Current, Non-Switching | 3A Per Common Terminal  |
| Maximum Rated Load, Switching             | 125 mA at 28 VDC or 115 VAC   |
| Minimum Switching Load                    | 0.01 mA at 0.02 VDC   |
| Contact Resistance (Initial)              | 100 mΩ Maximum  |
| (After Life)                              | 200 mΩ Maximum  |
| Insulation Resistance                     | 1,000 MΩ Minimum  |
| Dielectric Withstanding Voltage           | 1000 VAC (RMS) Single Pole Models<br>500 VAC (RMS) Double Pole Models |

### ENVIRONMENTAL

|                       |                 |
|-----------------------|-----------------|
| Operating Temperature | -40°C To +75°C  |
| Storage Temperature   | -65°C To +100°C |
| Seal                  | Optional O-Ring |

### MATERIALS

|                          |   |
|--------------------------|---|
| Plastic                  | Polycarbonate per Federal Spec LP-393A            |
| Metals                   | Corrosion Resistant                               |
| Circuit Board - Material | 0.063" Glass Epoxy                                |
| Plating                  | Gold Over Nickel Plating                          |
| Terminals                | Copper Alloy, Plated for Soldering                |
| Contacts                 | Bifurcated Copper Alloy, Gold Over Nickel Plating |
| O-Ring                   | Buna-N  |

### RoHS COMPLIANCE

EECO Switch is fully committed to complying with the European Lead-Free and RoHS directives. The 2000 series is lead free and RoHS compliant.



**2000 Series**

**OUTLINE DIMENSIONS**

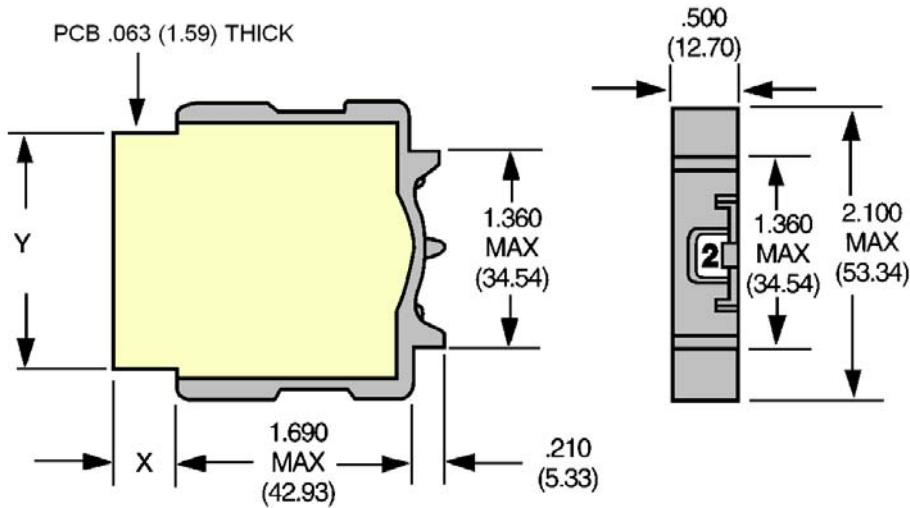

**SPACER - S20SG**

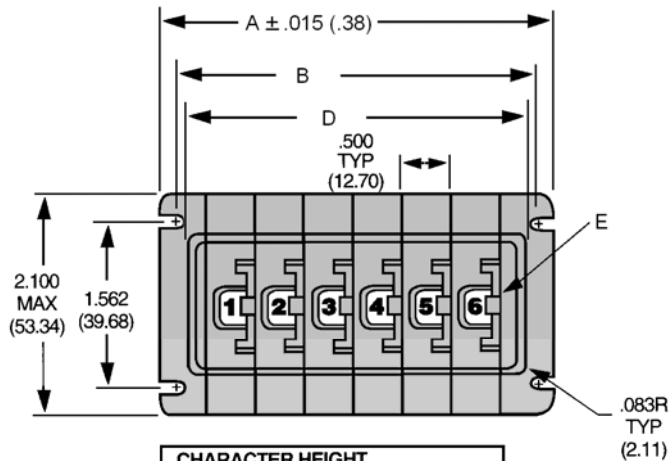
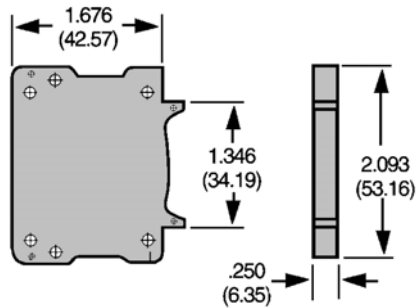

| CHARACTER HEIGHT<br>Dimension E |                     |
|---------------------------------|---------------------|
| .250 (6.35)                     | 8, 10 & 12 Position |
| .170 (4.32)                     | 16 Position         |

| No. Of<br>Stations | A               | B               | C               | D               |
|--------------------|-----------------|-----------------|-----------------|-----------------|
| 1                  | 1.38<br>(34.9)  | 1.08<br>(27.4)  | 0.89<br>(22.6)  | 0.88<br>(22.4)  |
| 2                  | 1.88<br>(47.6)  | 1.58<br>(40.1)  | 1.39<br>(35.3)  | 1.38<br>(35.1)  |
| 3                  | 2.38<br>(60.3)  | 2.08<br>(52.8)  | 1.89<br>(48.0)  | 1.88<br>(47.8)  |
| 4                  | 2.88<br>(73.0)  | 2.58<br>(65.5)  | 2.39<br>(60.7)  | 2.38<br>(60.5)  |
| 5                  | 3.38<br>(85.7)  | 3.08<br>(78.2)  | 2.89<br>(73.4)  | 2.88<br>(73.2)  |
| 6                  | 3.88<br>(98.4)  | 3.58<br>(90.9)  | 3.39<br>(86.1)  | 3.38<br>(85.9)  |
| 7                  | 4.38<br>(111.1) | 4.08<br>(103.6) | 3.89<br>(98.8)  | 3.88<br>(98.6)  |
| 8                  | 4.88<br>(123.8) | 4.58<br>(116.3) | 4.39<br>(111.5) | 4.38<br>(111.3) |
| 9                  | 5.38<br>(136.5) | 5.08<br>(129.0) | 4.89<br>(124.2) | 4.88<br>(124.0) |
| 10                 | 5.88<br>(149.2) | 5.58<br>(141.7) | 5.39<br>(136.9) | 5.38<br>(136.7) |

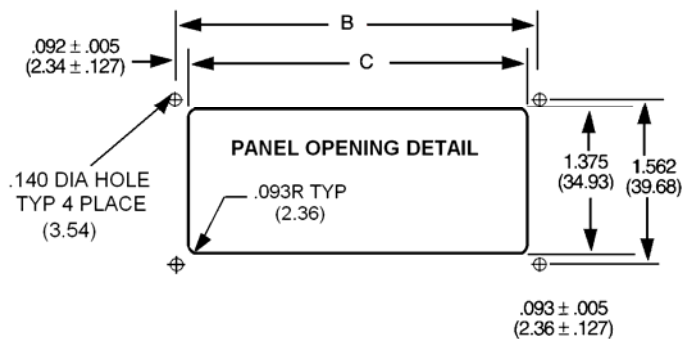

All dimensions in inches.  
Tolerances .XXX ± .010, .XX ± .03 unless noted.  
( ) Metric equivalents in mm.

Assembly may exhibit an expansion of .003" per station before installation but will adjust to recommended panel cutout when installed.  
Spacers count as stations. Subtract .250" from each dimension A through D when spacers are used.  
Add .500" to dimensions A through D for each additional station over 10.



## 2000 Series

| TRUTH<br>TABLE | PART<br>NUMBER | PART<br>DESCRIPTION  | NUMBER OF<br>POSITIONS | PCB TAIL<br>DIMENSIONS |      | TERMINATION |                    |
|----------------|----------------|--|------------------------|------------------------|------|-------------|--------------------|
|                |                |  |                        | X                      | Y    | †<br>TYPE   | CONNECTOR<br>CODE* |
| A01            | 2284G          | 1 Pole 8 Pos. Decimal  | 8                      | 0.34                   | 1.71 | E           | C                  |
| A02            | 2229G          | 1 Pole Decimal   | 10                     | 0.34                   | 2.02 | E           | E                  |
| A03            | 2281G          | 1 Pole 12 Pos. Decimal                                       | 12                     | 0.45                   | 2.33 | E           | ....               |
| A04            | 2283G          | 1 Pole 16 Pos. Decimal                                       | 16                     | 0.34                   | 1.71 | E           | D                  |
| A05            | 2217G          | 2 Pole Decimal   | 10                     | 1.40                   | 2.02 | E           | N/A                |
| B02            | 2214G          | 1 Pole BCD w/Diode Prov.                                     | 10                     | 0.98                   | 1.08 | E           | C                  |
| B02            | 2228G          | 1 Pole BCD   | 10                     | 0.34                   | 1.08 | E           | A                  |
| B03            | 2262G          | 1 Pole BCD (1-10 Marking)                                    | 10                     | 0.34                   | 1.08 | E           | A                  |
| B04            | 2245G          | 1 Pole 12 Pos. Binary w/Diode Prov.                          | 12                     | 0.98                   | 1.08 | W           | ....               |
| B05            | 2249G          | 1 Pole BCD Odd Bit Parity Diode Prov.                        | 10                     | 0.98                   | 1.08 | E           | A                  |
| B06            | 2227G          | 1 Pole BCD w/Even Bit Parity                                 | 10                     | 0.34                   | 1.08 | E           | A                  |
| C02            | 2205G          | 1 Pole BCD w/Compl Diode Prov.                               | 10                     | 0.98                   | 1.71 | E           | C                  |
| C02            | 2206G          | 1 Pole BCD w/Complement                                      | 10                     | 0.98                   | 1.71 | E           | C                  |
| C03            | 2263G          | 1 Pole BCD w/Compl. Diode Prov.<br>(1-10 Marking)            | 10                     | 0.98                   | 1.71 | E           | C                  |
| C06            | 2280G          | 1 Pole BCH w/Compl. Mkd 0-15                                 | 16                     | 0.34                   | 1.71 | E           | C                  |
| C06            | 2285G          | 1 Pole BCH w/Compl. Mkd 0-9-A-F                              | 16                     | 0.34                   | 1.71 | E           | C                  |
| C06            | 2286G          | 1 Pole BCH w/Diode Prov. Mkd 0-15                            | 16                     | 0.98                   | 1.71 | E           | C                  |
| C06            | 2296G          | 1 Pole BCH w/Diode Prov.                                     | 16                     | 0.98                   | 1.71 | E           | C                  |
| C07            | 2274G          | 1 Pole Excess 3 w/Complement                                 | 10                     | 0.34                   | 1.71 | E           | C                  |
| C08            | 2210G          | 1 Pole 9's Complement w/Complement                           | 10                     | 0.34                   | 1.71 | E           | C                  |
| C08            | 2250G          | 1 Pole 9's Compl. w/Compl Diode Prov.                        | 10                     | 0.98                   | 1.71 | E           | C                  |
| C09            | 2220G          | 1 Pole 10's Complement w/Compl.                              | 10                     | 0.34                   | 1.71 | E           | C                  |
| D02            | 2258G          | 2 Pole BCD w/Separate Common to Not<br>True Bits             | 10                     | 0.34                   | 1.71 | E           | C                  |
| D03            | 2276G          | 2 Pole BCD Diode Prov.                                       | 10                     | 0.98                   | 1.71 | E           | C                  |
| D04            | 2289G          | 2 Pole BCH w/Compl. Mkd 0-15                                 | 16                     | 0.34                   | 1.71 | E           | C                  |
| D04            | 2299G          | 2 Pole BCH w/Compl. Mkd 0-9-A-F                              | 16                     | 0.34                   | 1.71 | E           | C                  |
| D06            | 2287G          | 2 Pole BCH w/Separate Common To<br>Not True Bits Mkd 0-9-A-F | 16                     | 0.34                   | 1.71 | E           | C                  |
| D06            | 2288G          | 2 Pole BCH w/Separate Common To<br>Not True Bits Mkd 0-15    | 16                     | 0.34                   | 1.71 | E           | C                  |
| E01            | 2235G          | 2 Pole BCO w/Complement                                      | 8                      | 0.34                   | 1.71 | E           | C                  |
| E02            | 2257G          | 2 Pole BCD w/Complement                                      | 10                     | 0.34                   | 1.71 | E           | C                  |
| F01            | 2233G          | 2 Pole BCD and Decimal                                       | 10                     | 0.34                   | 1.71 | C           | D                  |
| S01            | 2264G          | 2 Pole 2 Position Marked +/-                                 | 2                      | 0.34                   | 1.08 | E           | A                  |
| S01            | 2266G          | 2 Pole 2 Position Marked 0-1                                 | 2                      | 0.34                   | 1.08 | E           | A                  |
| S05            | 2208G          | Biquinary  | 10                     | 0.34                   | 1.08 | W           | ....               |
| S06            | 2253G          | NOT/NOR (All Shorted But One) Decimal                        | 12                     | 0.34                   | 2.33 | E           | ....               |
| S07            | 2234G          | Incremental Voltage Divider                                  | 10                     | 1.79                   | 1.08 | E           | A                  |
| S08            | 2216G          | Wolff-Poggendorf Voltage Divider                             | 10                     | 1.79                   | 1.08 | E           | A                  |
| S09            | 2272G          | 1-2-3-4 Capacitor Decade                                     | 10                     | 1.88                   | 1.08 | E           | A                  |
| S10            | 2268G          | 1-2-3-6 Resistor Decade                                      | 10                     | 2.08                   | 1.08 | E           | A                  |
| S11            | 2223G          | 7 Bar Indicator  | 10                     | 0.34                   | 1.71 | C           | C                  |
| S12            | 2278G          | Kelvin-Varley Voltage Divider<br>Make Before Break           | 10                     | 1.41                   | 2.02 | W           |                    |

† **Type Codes:** **C**-Connector Only **E**-Either Connector Or Direct Wire **W**-Direct Wire Only

Replace "G" with "M" in part number for spray matte finish.



## 2000 Series

### AVAILABLE OPTIONS

|   |  |
|---|--|
| A | Diodes Installed Anode To Common   |
| C | Diodes Installed Cathode To Common   |
| D | Decimal Point  |
| K | Lighted Decimal Point  |
| L | Lighted Switch Legend. Black hot-stamped character on white translucent background. 5 Volt lamp standard, consult factory for other voltages |
| M | Spray Matte Finish   |
| P | +/- Rotor Marking  |
| R | Reverse Lighting. Illuminated white character on black background  |
| S | Sealed Switch  |
| T | Alphabet Marking   |
| U | EMI/RFI Shielding  |
|   | Stop Pins  |
|   | Consult Factory for Custom Rotor Marking, Custom Output Codes and Other Special Requests   |

### 2000 HARDWARE AND ACCESSORIES

**19SG-X** Standard Hardware Kit: Endpieces, Threaded Rods, Screws, Nuts and Washers

**NOTE:** REPLACE "G" WITH "M" TO ORDER SPRAY MATTE HARDWARE  
REPLACE "X" WITH THE APPROPRIATE NUMBER OF SWITCHES IN ASSEMBLY

| CATALOG NUMBER | DESCRIPTION        | PART NUMBER |
|----------------|--------------------|-------------|
| E20SG          | Endpiece Gloss     | 197788-01   |
| E20SM          | Endpiece Matte     | 197788-02   |
| S20SG          | .250" Spacer Gloss | 197787-01   |
| S20SM          | .250" Spacer Matte | 197787-02   |

| * CONNECTOR CODE |                   |
|------------------|-------------------|
| LETTER           | CINCH PART NUMBER |
| A                | 50-6A-20          |
| B                | 50-12A-30         |
| C                | 50-10A-20         |
| D                | 50-20A-30         |
| E                | 50-12A-20         |

**NOTE:** Cinch connector information is supplied for reference only. Information shown is deemed accurate but not guaranteed. EECO does not supply Cinch or other connectors for this product. Consult an appropriate connector supplier for additional information.

### ORDERING EXAMPLE - SWITCH

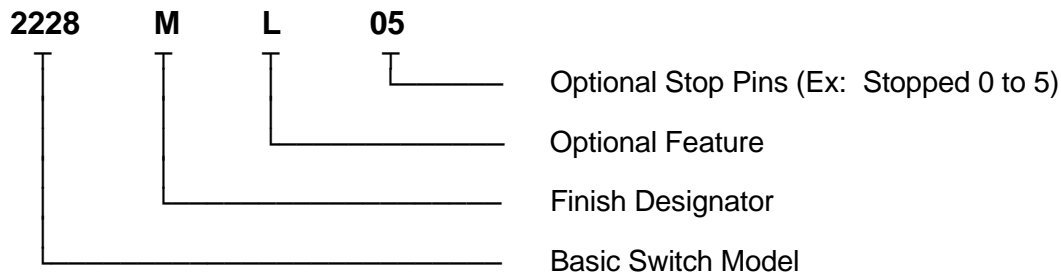

### ORDERING EXAMPLE

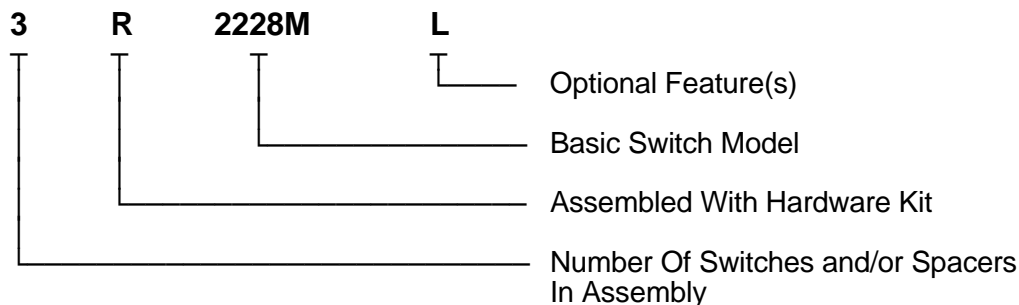

Certain combinations of switches and options may require a special part number. Consult factory for additional ordering information.



# EECO SWITCH STANDARD TRUTH TABLES

EECO Switch offers over 60 binary, decimal, and special purpose electrical output codes. The code designations (e.g. B02) are common to all EECO Switch products. Not all codes are offered in every switch series.

Using the truth tables on the following pages, select the electrical code that suits your circuit. Then select the corresponding 2000 Series part number from the table on page 4. The most common output codes are highlighted in *red*

Contact the factory for additional information and availability of other codes and options.

## SINGLE POLE DECIMAL CODES

**A01**

| OCTAL 1 Pole 8 Position |   |
|-------------------------|---|
| D I A                   | Common (C) connected to terminals indicated |
| L                       | 0 1 2 3 4 5 6 7                             |
| 0                       | ●   |
| 1                       | ●   |
| 2                       | ●   |
| 3                       | ●   |
| 4                       | ●   |
| 5                       | ●   |
| 6                       | ●   |
| 7                       | ●   |

**A02**

| DECIMAL 1 Pole 10 Position |   |
|----------------------------|---|
| D I A                      | Common (C) connected to terminals indicated |
| L                          | 0 1 2 3 4 5 6 7 8 9                         |
| 0                          | ●   |
| 1                          | ●   |
| 2                          | ●   |
| 3                          | ●   |
| 4                          | ●   |
| 5                          | ●   |
| 6                          | ●   |
| 7                          | ●   |
| 8                          | ●   |
| 9                          | ●   |

**A03**

| 1 Pole 12 Position |   |
|--------------------|---|
| D I A              | Common (C) connected to terminals indicated |
| L                  | 0 1 2 3 4 5 6 7 8 9 10 11                   |
| 0                  | ●   |
| 1                  | ●   |
| 2                  | ●   |
| 3                  | ●   |
| 4                  | ●   |
| 5                  | ●   |
| 6                  | ●   |
| 7                  | ●   |
| 8                  | ●   |
| 9                  | ●   |
| 10                 | ●   |
| 11                 | ●   |

**A04**

| 1 Pole 16 Position |   |
|--------------------|---|
| D I A              | Common (C) connected to terminals indicated |
| L                  | 0 1 2 3 4 5 6 7 8 9 10 11 12 13 14 15       |
| 0                  | ●   |
| 1                  | ●   |
| 2                  | ●   |
| 3                  | ●   |
| 4                  | ●   |
| 5                  | ●   |
| 6                  | ●   |
| 7                  | ●   |
| 8                  | ●   |
| 9                  | ●   |
| 10                 | ●   |
| 11                 | ●   |
| 12                 | ●   |
| 13                 | ●   |
| 14                 | ●   |
| 15                 | ●   |

## DOUBLE POLE DECIMAL CODES

**A05**

| DECIMAL 2 Pole 10 Position |   |
|----------------------------|---|
| D I A                      | Common (C) connected to terminals indicated |
| L                          | 0 1 2 3 4 5 6 7 8 9                         |
| 0                          | ●   |
| 1                          | ●   |
| 2                          | ●   |
| 3                          | ●   |
| 4                          | ●   |
| 5                          | ●   |
| 6                          | ●   |
| 7                          | ●   |
| 8                          | ●   |
| 9                          | ●   |

**A06**

| DECIMAL 2 Pole 10 Position<br>One Pole Shorting One Pole Non-Shorting |   |
|---|---|
| D I A   | Common (C) connected to terminals indicated |
| L   | 0 1 2 3 4 5 6 7 8 9                         |
| 0   | ●   |
| 1   | ●   |
| 2   | ●   |
| 3   | ●   |
| 4   | ●   |
| 5   | ●   |
| 6   | ●   |
| 7   | ●   |
| 8   | ●   |
| 9   | ●   |

**A07**

| DECIMAL 1 Pole 12 Position |   |
|----------------------------|---|
| D I A                      | Common (C) connected to terminals indicated |
| L                          | 0 1 2 3 4 5 6 7 8 9 10 11                   |
| 0                          | ●   |
| 1                          | ●   |
| 2                          | ●   |
| 3                          | ●   |
| 4                          | ●   |
| 5                          | ●   |
| 6                          | ●   |
| 7                          | ●   |
| 8                          | ●   |
| 9                          | ●   |
| 10                         | ●   |
| 11                         | ●   |

**A08**

| 2 Pole 5 Position |  |
|-------------------|--|
| D I A             | Common (C) and (C') connected to terminals indicated |
| L                 | 0 1 2 3 4  |
| 0                 | ●  |
| 1                 | ●  |
| 2                 | ●  |
| 3                 | ●  |
| 4                 | ●  |



**B01**

|     |   |   |   |            |  |
|-----|---|---|---|------------|--|
| BCD |   | 1 Pole                                      |   | 8 Position |  |
| D   | I | Common (C) connected to terminals indicated |   |            |  |
| A   | L | 1   | 2 | 4          |  |
| 0   | 1 | ●   |   |            |  |
| 2   | 2 | ●   |   |            |  |
| 3   | 3 | ●   | ● |            |  |
| 4   | 4 |   |   | ●          |  |
| 5   | 5 |   |   | ●          |  |
| 6   | 6 | ●   | ● |            |  |
| 7   | 7 | ●   | ● |            |  |

**B02**

|     |   |   |   |             |   |
|-----|---|---|---|-------------|---|
| BCD |   | 1 Pole                                      |   | 10 Position |   |
| D   | I | Common (C) connected to terminals indicated |   |             |   |
| A   | L | 1   | 2 | 4           | 8 |
| 0   | 1 | ●   |   |             |   |
| 2   | 2 |   | ● |             |   |
| 3   | 3 | ●   | ● |             |   |
| 4   | 4 |   |   | ●           |   |
| 5   | 5 | ●   | ● |             |   |
| 6   | 6 | ●   | ● |             |   |
| 7   | 7 | ●   | ● |             |   |
| 8   | 8 |   |   | ●           |   |
| 9   | 9 | ●   |   |             | ● |

**B03**

|                     |   |   |   |             |   |
|---------------------|---|---|---|-------------|---|
| BCD, binary 10 at 0 |   | 1 Pole                                      |   | 10 Position |   |
| D                   | I | Common (C) connected to terminals indicated |   |             |   |
| A                   | L | 1   | 2 | 4           | 8 |
| 0                   | 1 | ●   |   |             |   |
| 2                   | 2 |   | ● |             |   |
| 3                   | 3 | ●   | ● |             |   |
| 4                   | 4 |   |   | ●           |   |
| 5                   | 5 | ●   | ● |             |   |
| 6                   | 6 | ●   | ● |             |   |
| 7                   | 7 | ●   | ● |             |   |
| 8                   | 8 |   |   | ●           |   |
| 9                   | 9 | ●   |   |             | ● |
| 0                   | 0 | ●   |   |             |   |

**B04**

|             |    |   |   |             |   |
|-------------|----|---|---|-------------|---|
| BINARY CODE |    | 1 Pole                                      |   | 12 Position |   |
| D           | I  | Common (C) connected to terminals indicated |   |             |   |
| A           | L  | 1   | 2 | 4           | 8 |
| 0           | 1  | ●   |   |             |   |
| 2           | 2  | ●   | ● |             |   |
| 3           | 3  | ●   | ● |             |   |
| 4           | 4  |   |   | ●           |   |
| 5           | 5  | ●   | ● |             |   |
| 6           | 6  | ●   | ● |             |   |
| 7           | 7  | ●   | ● |             |   |
| 8           | 8  |   |   | ●           |   |
| 9           | 9  | ●   |   |             | ● |
| 10          | 10 | ●   | ● |             |   |
| 11          | 11 | ●   | ● |             |   |

**B05**

|                          |   |   |   |             |     |
|--------------------------|---|---|---|-------------|-----|
| BCD, with Odd Bit Parity |   | 1 Pole                                      |   | 10 Position |     |
| D                        | I | Common (C) connected to terminals indicated |   |             |     |
| A                        | L | 1   | 2 | 4           | 8 P |
| 0                        | 1 | ●   |   |             | ●   |
| 2                        | 2 |   | ● |             |     |
| 3                        | 3 | ●   | ● |             | ●   |
| 4                        | 4 |   |   | ●           |     |
| 5                        | 5 | ●   | ● |             | ●   |
| 6                        | 6 | ●   | ● |             | ●   |
| 7                        | 7 | ●   | ● |             | ●   |
| 8                        | 8 |   |   | ●           |     |
| 9                        | 9 | ●   |   |             | ●   |

**B06**

|                           |   |   |   |             |     |
|---------------------------|---|---|---|-------------|-----|
| BCD, with Even Bit Parity |   | 1 Pole                                      |   | 10 Position |     |
| D                         | I | Common (C) connected to terminals indicated |   |             |     |
| A                         | L | 1   | 2 | 4           | 8 P |
| 0                         | 1 | ●   |   |             |     |
| 2                         | 2 |   | ● |             |     |
| 3                         | 3 | ●   | ● |             | ●   |
| 4                         | 4 |   |   | ●           |     |
| 5                         | 5 | ●   | ● |             | ●   |
| 6                         | 6 | ●   | ● |             | ●   |
| 7                         | 7 | ●   | ● |             | ●   |
| 8                         | 8 |   |   | ●           |     |
| 9                         | 9 | ●   |   |             | ●   |

**B07**

|             |    |   |   |             |   |
|-------------|----|---|---|-------------|---|
| Binary Code |    | 1-Pole                                    |   | 16-Position |   |
| D           | I  | Common C connected to terminals indicated |   |             |   |
| A           | L  | 1   | 2 | 4           | 8 |
| 0           | 0  | ●   |   |             |   |
| 1           | 1  | ●   |   |             |   |
| 2           | 2  |   | ● |             |   |
| 3           | 3  | ●   | ● |             |   |
| 4           | 4  |   |   | ●           |   |
| 5           | 5  | ●   | ● |             |   |
| 6           | 6  | ●   | ● |             |   |
| 7           | 7  | ●   | ● |             |   |
| 8           | 8  |   |   | ●           |   |
| 9           | 9  | ●   |   |             | ● |
| A           | 10 | ●   |   |             |   |
| B           | 11 | ●   | ● |             |   |
| C           | 12 |   |   | ●           |   |
| D           | 13 | ●   | ● |             |   |
| E           | 14 | ●   |   |             | ● |
| F           | 15 | ●   | ● |             |   |

**C02**

|                  |   |   |   |             |   |
|------------------|---|---|---|-------------|---|
| BCD w/Complement |   | 1 Pole                                      |   | 10 Position |   |
| D                | I | Common (C) connected to terminals indicated |   |             |   |
| A                | L | 1   | 2 | 4           | 8 |
| 0                | 1 |   |   | ●           | ● |
| 2                | 2 | ●   |   |             |   |
| 3                | 3 | ●   | ● |             |   |
| 4                | 4 |   |   | ●           |   |
| 5                | 5 | ●   | ● |             |   |
| 6                | 6 | ●   | ● |             |   |
| 7                | 7 | ●   | ● |             |   |
| 8                | 8 |   |   | ●           |   |
| 9                | 9 | ●   |   |             | ● |

**C03**

|                  |   |   |   |        |   |             |   |   |   |
|------------------|---|---|---|--------|---|-------------|---|---|---|
| BCD w/Complement |   | Binary 10 at 0                              |   | 1 Pole |   | 10 Position |   |   |   |
| D                | I | Common (C) connected to terminals indicated |   |        |   |             |   |   |   |
| A                | L | 1   | 2 | 4      | 8 | 1           | 2 | 4 | 8 |
| 0                | 1 | ●   |   |        |   |             |   |   |   |
| 2                | 2 |   | ● |        |   |             |   |   |   |
| 3                | 3 | ●   | ● |        |   |             |   |   |   |
| 4                | 4 |   |   | ●      |   |             |   |   |   |
| 5                | 5 | ●   | ● |        |   |             |   |   |   |
| 6                | 6 | ●   | ● |        |   |             |   |   |   |
| 7                | 7 | ●   | ● |        |   |             |   |   |   |
| 8                | 8 |   |   | ●      |   |             |   |   |   |
| 9                | 9 | ●   |   |        |   |             |   |   | ● |
| 0                | 0 | ●   |   |        |   |             |   |   |   |

**C04**

|                          |    |   |   |             |   |   |   |   |   |
|--------------------------|----|---|---|-------------|---|---|---|---|---|
| Binary Code w/Complement |    | 1 Pole                                      |   | 12 Position |   |   |   |   |   |
| D                        | I  | Common (C) connected to terminals indicated |   |             |   |   |   |   |   |
| A                        | L  | 1   | 2 | 4           | 8 | 1 | 2 | 4 | 8 |
| 0                        | 1  | ●   |   |             |   |   |   |   |   |
| 2                        | 2  | ●   | ● |             |   |   |   |   |   |
| 3                        | 3  | ●   | ● |             |   |   |   |   |   |
| 4                        | 4  |   |   | ●           |   |   |   |   |   |
| 5                        | 5  | ●   | ● |             |   |   |   |   |   |
| 6                        | 6  | ●   | ● |             |   |   |   |   |   |
| 7                        | 7  | ●   | ● |             |   |   |   |   |   |
| 8                        | 8  |   |   | ●           |   |   |   |   |   |
| 9                        | 9  | ●   |   |             |   |   |   |   | ● |
| A                        | 10 | ●   |   |             |   |   |   |   |   |
| B                        | 11 | ●   | ● |             |   |   |   |   |   |
| C                        | 12 |   |   | ●           |   |   |   |   |   |
| D                        | 13 | ●   | ● |             |   |   |   |   |   |
| E                        | 14 | ●   |   |             |   |   |   |   | ● |
| F                        | 15 | ●   | ● |             |   |   |   |   |   |

**C06**

|                          |    |   |   |             |   |   |   |   |   |
|--------------------------|----|---|---|-------------|---|---|---|---|---|
| Binary Code w/Complement |    | 1-Pole                                      |   | 16-Position |   |   |   |   |   |
| D                        | I  | Common (C) connected to terminals indicated |   |             |   |   |   |   |   |
| A                        | L  | 1   | 2 | 4           | 8 | 1 | 2 | 4 | 8 |
| 0                        | 0  |   |   |             |   | ● | ● |   |   |
| 1                        | 1  | ●   |   |             |   |   |   |   |   |
| 2                        | 2  | ●   | ● |             |   |   |   |   |   |
| 3                        | 3  | ●   | ● |             |   |   |   |   |   |
| 4                        | 4  |   |   | ●           |   |   |   |   |   |
| 5                        | 5  | ●   | ● |             |   |   |   |   |   |
| 6                        | 6  | ●   | ● |             |   |   |   |   |   |
| 7                        | 7  | ●   | ● |             |   |   |   |   |   |
| 8                        | 8  |   |   | ●           |   |   |   |   |   |
| 9                        | 9  | ●   |   |             |   |   |   |   | ● |
| A                        | 10 | ●   |   |             |   |   |   |   |   |
| B                        | 11 | ●   | ● |             |   |   |   |   |   |
| C                        | 12 |   |   | ●           |   |   |   |   |   |
| D                        | 13 | ●   | ● |             |   |   |   |   |   |
| E                        | 14 | ●   |   |             |   |   |   |   | ● |
| F                        | 15 | ●   | ● |             |   |   |   |   |   |

**C07**

|                            |   |   |   |             |   |
|----------------------------|---|---|---|-------------|---|
| BCD Excess 3, w/Complement |   | 1 Pole                                      |   | 10 Position |   |
| D                          | I | Common (C) connected to terminals indicated |   |             |   |
| A                          | L | 1   | 2 | 4           | 8 |
| 0                          | 1 | ●   |   |             |   |
| 2                          | 2 | ●   | ● |             |   |
| 3                          | 3 | ●   | ● |             |   |
| 4                          | 4 |   |   | ●           |   |
| 5                          | 5 | ●   | ● |             |   |
| 6                          | 6 | ●   | ● |             |   |
| 7                          | 7 | ●   | ● |             |   |
| 8                          | 8 |   |   | ●           |   |
| 9                          | 9 | ●   |   |             | ● |

**C08**

|                                  |   |   |   |             |   |
|----------------------------------|---|---|---|-------------|---|
| 9's Complement BCD, w/Complement |   | 1 Pole                                      |   | 10 Position |   |
| D                                | I | Common (C) connected to terminals indicated |   |             |   |
| A                                | L | 1   | 2 | 4           | 8 |
| 0                                | 1 |   |   | ●           | ● |
| 2                                | 2 | ●   |   |             |   |
| 3                                | 3 | ●   | ● |             |   |
| 4                                | 4 |   |   | ●           |   |
| 5                                | 5 | ●   | ● |             |   |
| 6                                | 6 | ●   | ● |             |   |
| 7                                | 7 | ●   | ● |             |   |
| 8                                | 8 |   |   | ●           |   |
| 9                                | 9 | ●   |   |             | ● |

**C09**

|                                   |   |   |   |             |   |
|-----------------------------------|---|---|---|-------------|---|
| 10's Complement BCD, w/Complement |   | 1 Pole                                      |   | 10 Position |   |
| D                                 | I | Common (C) connected to terminals indicated |   |             |   |
| A                                 | L | 1   | 2 | 4           | 8 |
| 0                                 | 1 |   |   | ●           | ● |
| 2                                 | 2 | ●   |   |             |   |
| 3                                 | 3 | ●   | ● |             |   |
| 4                                 | 4 |   |   | ●           |   |
| 5                                 | 5 | ●   | ● |             |   |
| 6                                 | 6 | ●   | ● |             |   |
| 7                                 | 7 | ●   | ● |             |   |
| 8                                 | 8 |   |   | ●           |   |
| 9                                 | 9 | ●   |   |             | ● |
| 0                                 | 0 | ●   |   |             |   |

**C10**

|              |   |   |   |             |   |
|--------------|---|---|---|-------------|---|
| BCD Excess 3 |   | 1 Pole                                      |   | 10 Position |   |
| D            | I | Common (C) connected to terminals indicated |   |             |   |
| A            | L | 1   | 2 | 4           | 8 |
| 0            | 1 | ●   |   |             |   |
| 2            | 2 | ●   | ● |             |   |
| 3            | 3 | ●   | ● |             |   |
| 4            | 4 |   |   | ●           |   |
| 5            | 5 | ●   | ● |             |   |
| 6            | 6 | ●   | ● |             |   |
| 7            | 7 | ●   | ● |             |   |
| 8            | 8 |   |   | ●           |   |
| 9            | 9 | ●   |   |             | ● |

**C16**

|                        |    |   |   |             |   |
|------------------------|----|---|---|-------------|---|
| Binary Complement only |    | 1-Pole                                      |   | 16-Position |   |
| D                      | I  | Common (C) connected to terminals indicated |   |             |   |
| A                      | L  | 1   | 2 | 4           | 8 |
| 0                      | 0  | ●   | ● |             |   |
| 1                      | 1  | ●   | ● |             |   |
| 2                      | 2  | ●   | ● |             |   |
| 3                      | 3  | ●   | ● |             |   |
| 4                      | 4  |   |   | ●           |   |
| 5                      | 5  | ●   | ● |             |   |
| 6                      | 6  | ●   | ● |             |   |
| 7                      | 7  |   |   | ●           |   |
| 8                      | 8  | ●   | ● |             |   |
| 9                      | 9  | ●   | ● |             |   |
| A                      | 10 | ●   | ● |             |   |
| B                      | 11 |   |   | ●           |   |
| C                      | 12 | ●   | ● |             |   |
| D                      | 13 | ●   | ● |             |   |
| E                      | 14 | ●   | ● |             |   |
| F                      | 15 | ●   | ● |             |   |

**C11**

|                     |   |   |   |            |  |
|---------------------|---|---|---|------------|--|
| BCD Complement Only |   | 1 Pole                                      |   | 8 Position |  |
| D                   | I | Common (C) connected to terminals indicated |   |            |  |
| A                   | L | 1   | 2 | 4          |  |
| 0                   | 1 | ●   |   |            |  |
| 2                   |   |   |   |            |  |



| D01   |   | D02  |   | D03                             |   | D04  |  | D06                                      |   |
|---|---|--|---|---------------------------------|---|--|--|--|---|
| BCD 2 Pole 8 Position<br>w/Sep Com to NT Bits |   | BCD 2 Pole 10 Position<br>Sep Com to NT Bits |   | BCD Dual,<br>2 Pole 10 Position |   | Binary Code w/Complement<br>2 Pole 16 Position |  | 2 Pole Binary with<br>Sep Com to NT Bits |   |
| D   | Common C (●) and C (*) connected to terminals indicated | D  | Common C (●) and C (*) connected to terminals indicated | D                               | Common (C1) and (C2) connected to terminals indicated | D  | Common (C) and (C̄) connected to terminals indicated | D  | Common C (●) and C (*) connected to terminals indicated |
| I   |   | I  |   | I                               |   | I  |  | I  |   |
| A   |   | A  |   | A                               |   | A  |  | A  |   |
| L   | 1 2 4   | L  | 1 2 4 8   | L                               | C1 C2<br>1 2 4 8 1 2 4 8                              | L  | 1 2 4 8 1 2 4 8                                      | L  | 1 2 4 8   |
| 0   | ● ● ●   | 0  | ● ● ● ●   | 0                               |   | 0  | ● ● ● ● ● ● ● ●                                      | 0  | ● ● ● ●   |
| 1   | ● ● ●   | 1  | ● ● ● ●   | 1                               | ●   | 1  | ● ● ● ● ● ● ● ●                                      | 1  | ● ● ● ●   |
| 2   | ● ● ●   | 2  | ● ● ● ●   | 2                               | ● ●   | 2  | ● ● ● ● ● ● ● ●                                      | 2  | ● ● ● ●   |
| 3   | ● ● ●   | 3  | ● ● ● ●   | 3                               | ● ● ●   | 3  | ● ● ● ● ● ● ● ●                                      | 3  | ● ● ● ●   |
| 4   | ● ● ●   | 4  | ● ● ● ●   | 4                               | ● ● ● ●   | 4  | ● ● ● ● ● ● ● ●                                      | 4  | ● ● ● ●   |
| 5   | ● ● ●   | 5  | ● ● ● ●   | 5                               | ● ● ● ● ●   | 5  | ● ● ● ● ● ● ● ●                                      | 5  | ● ● ● ●   |
| 6   | ● ● ●   | 6  | ● ● ● ●   | 6                               | ● ● ● ● ● ●   | 6  | ● ● ● ● ● ● ● ●                                      | 6  | ● ● ● ●   |
| 7   | ● ● ●   | 7  | ● ● ● ●   | 7                               | ● ● ● ● ● ● ●   | 7  | ● ● ● ● ● ● ● ●                                      | 7  | ● ● ● ●   |
|   |   | 8  | ● ● ● ●   | 8                               | ● ● ● ● ● ● ● ●                                       | 8  | ● ● ● ● ● ● ● ●                                      | 8  | ● ● ● ●   |
|   |   | 9  | ● ● ● ●   | 9                               | ● ● ● ● ● ● ● ●                                       | 9  | ● ● ● ● ● ● ● ●                                      | 9  | ● ● ● ●   |
|   |   |  |   |                                 |   | A  | ● ● ● ● ● ● ● ●                                      | A  | ● ● ● ●   |
|   |   |  |   |                                 |   | B  | ● ● ● ● ● ● ● ●                                      | B  | ● ● ● ●   |
|   |   |  |   |                                 |   | C  | ● ● ● ● ● ● ● ●                                      | C  | ● ● ● ●   |
|   |   |  |   |                                 |   | D  | ● ● ● ● ● ● ● ●                                      | D  | ● ● ● ●   |
|   |   |  |   |                                 |   | E  | ● ● ● ● ● ● ● ●                                      | E  | ● ● ● ●   |
|   |   |  |   |                                 |   | F  | ● ● ● ● ● ● ● ●                                      | F  | ● ● ● ●   |

| E01                                   |  | E02                                    |  | E04   |  | E05  |  |
|---------------------------------------|--|--|--|---|--|--|--|
| BCD w/Complement<br>2 Pole 8 Position |  | BCD w/Complement<br>2 Pole 10 Position |  | 9's Complement BCD,<br>w/Complement<br>2 Pole 10 Position |  | 10's Complement BCD,<br>w/Complement<br>2 Pole 10 Position |  |
| D                                     | Common (C) and (C̄) connected to terminals indicated | D                                      | Common (C) and (C̄) connected to terminals indicated | D   | Common (C) and (C̄) connected to terminals indicated | D  | Common (C) and (C̄) connected to terminals indicated |
| I                                     |  | I                                      |  | I   |  | I  |  |
| A                                     |  | A                                      |  | A   |  | A  |  |
| L                                     | C C̄<br>1 2 4 1 2 4                                  | L                                      | C C̄<br>1 2 4 8 1 2 4 8                              | L   | C C̄<br>1 2 4 8 1 2 4 8                              | L  | C C̄<br>1 2 4 8 1 2 4 8                              |
| 0                                     |  | 0                                      | ● ● ● ●  | 0   | ● ● ● ● ● ● ● ●                                      | 0  | ● ● ● ● ● ● ● ●                                      |
| 1                                     | ●  | 1                                      | ● ● ● ●  | 1   | ● ● ● ● ● ● ● ●                                      | 1  | ● ● ● ● ● ● ● ●                                      |
| 2                                     | ●  | 2                                      | ● ● ● ●  | 2   | ● ● ● ● ● ● ● ●                                      | 2  | ● ● ● ● ● ● ● ●                                      |
| 3                                     | ●  | 3                                      | ● ● ● ●  | 3   | ● ● ● ● ● ● ● ●                                      | 3  | ● ● ● ● ● ● ● ●                                      |
| 4                                     | ●  | 4                                      | ● ● ● ●  | 4   | ● ● ● ● ● ● ● ●                                      | 4  | ● ● ● ● ● ● ● ●                                      |
| 5                                     | ●  | 5                                      | ● ● ● ●  | 5   | ● ● ● ● ● ● ● ●                                      | 5  | ● ● ● ● ● ● ● ●                                      |
| 6                                     | ●  | 6                                      | ● ● ● ●  | 6   | ● ● ● ● ● ● ● ●                                      | 6  | ● ● ● ● ● ● ● ●                                      |
| 7                                     | ●  | 7                                      | ● ● ● ●  | 7   | ● ● ● ● ● ● ● ●                                      | 7  | ● ● ● ● ● ● ● ●                                      |
|                                       |  | 8                                      | ● ● ● ●  | 8   | ● ● ● ● ● ● ● ●                                      | 8  | ● ● ● ● ● ● ● ●                                      |
|                                       |  | 9                                      | ● ● ● ●  | 9   | ● ● ● ● ● ● ● ●                                      | 9  | ● ● ● ● ● ● ● ●                                      |
|                                       |  |  |  |   |  | 0  | ● ● ● ● ● ● ● ●                                      |

| E06  |  | E07   |  | E08                                 |   |
|--|--|---|--|-------------------------------------|---|
| Binary Code w/Complement<br>2 Pole 12 Position |  | BCD Excess 3,<br>w/Complement<br>2 Pole 10 Position |  | Special 4 Pole, BCD<br>w/Complement |   |
| D  | Common (C) and (C̄) connected to terminals indicated | D   | Common (C) and (C̄) connected to terminals indicated | D                                   | Common (C1), (C2), (C3) and (C4) connected to terminals indicated |
| I  |  | I   |  | I                                   |   |
| A  |  | A   |  | A                                   |   |
| L  | C C̄<br>1 2 4 8 1 2 4 8                              | L   | C C̄<br>1 2 4 8 1 2 4 8                              | L                                   | C1 C2 C3 C4<br>1 1 2 2 4 4 8 8                                    |
| 0  |  | 0   | ● ● ● ●  | 0                                   | ● ● ● ● ● ● ● ●   |
| 1  | ●  | 1   | ● ● ● ●  | 1                                   | ● ● ● ● ● ● ● ●   |
| 2  | ●  | 2   | ● ● ● ●  | 2                                   | ● ● ● ● ● ● ● ●   |
| 3  | ●  | 3   | ● ● ● ●  | 3                                   | ● ● ● ● ● ● ● ●   |
| 4  | ●  | 4   | ● ● ● ●  | 4                                   | ● ● ● ● ● ● ● ●   |
| 5  | ●  | 5   | ● ● ● ●  | 5                                   | ● ● ● ● ● ● ● ●   |
| 6  | ●  | 6   | ● ● ● ●  | 6                                   | ● ● ● ● ● ● ● ●   |
| 7  | ●  | 7   | ● ● ● ●  | 7                                   | ● ● ● ● ● ● ● ●   |
| 8  | ●  | 8   | ● ● ● ●  | 8                                   | ● ● ● ● ● ● ● ●   |
| 9  | ●  | 9   | ● ● ● ●  | 9                                   | ● ● ● ● ● ● ● ●   |
| 10   | ●  |   |  |                                     |   |
| 11   | ●  |   |  |                                     |   |



**F01**

BCD and Non-Shorting DECIMAL  
2 Pole 10 Position

D I A L Common (C1) and (C2) connected to terminals indicated

|   |    |   |   |   |    |   |   |   |   |   |   |   |   |   |
|---|----|---|---|---|----|---|---|---|---|---|---|---|---|---|
|   | C1 |   |   |   | C2 |   |   |   |   |   |   |   |   |   |
| L | 1  | 2 | 4 | 8 | 0  | 1 | 2 | 3 | 4 | 5 | 6 | 7 | 8 | 9 |
| 0 |    |   |   |   | ●  |   |   |   |   |   |   |   |   |   |
| 1 | ●  |   |   |   |    | ● |   |   |   |   |   |   |   |   |
| 2 |    | ● |   |   |    |   | ● |   |   |   |   |   |   |   |
| 3 | ●  | ● |   |   |    |   |   | ● |   |   |   |   |   |   |
| 4 |    |   | ● |   |    |   |   |   | ● |   |   |   |   |   |
| 5 | ●  | ● |   |   |    |   |   |   |   | ● |   |   |   |   |
| 6 |    | ● | ● |   |    |   |   |   |   |   | ● |   |   |   |
| 7 | ●  | ● | ● |   |    |   |   |   |   |   |   | ● |   |   |
| 8 |    |   |   | ● |    |   |   |   |   |   |   |   | ● |   |
| 9 | ●  |   |   |   |    | ● |   |   |   |   |   |   |   | ● |

**G01**

1-2-2'-4 Berkeley Code  
1 Pole 10 Position

D I A L Common (C) connected to terminals indicated

|   |   |   |    |   |
|---|---|---|----|---|
| L | 1 | 2 | 2' | 4 |
| 0 |   |   |    |   |
| 1 | ● |   |    |   |
| 2 |   | ● |    |   |
| 3 | ● | ● |    |   |
| 4 |   |   | ●  | ● |
| 5 | ● | ● | ●  |   |
| 6 |   | ● | ●  | ● |
| 7 | ● | ● | ●  |   |
| 8 |   | ● | ●  | ● |
| 9 | ● | ● | ●  | ● |

**G02**

1-2-4-2' Berkeley Code  
1 Pole 10 Position

D I A L Common (C) connected to terminals indicated

|   |   |   |   |    |
|---|---|---|---|----|
| L | 1 | 2 | 4 | 2' |
| 0 |   |   |   |    |
| 1 | ● |   |   |    |
| 2 |   | ● |   |    |
| 3 | ● | ● |   |    |
| 4 |   |   | ● |    |
| 5 | ● | ● | ● |    |
| 6 |   | ● | ● | ●  |
| 7 | ● | ● | ● |    |
| 8 |   | ● | ● | ●  |
| 9 | ● | ● | ● | ●  |

**H01**

1-2-4-2' Berkeley Code w/Complement  
1 Pole 10 Position

D I A L Common (C) connected to terminals indicated

|   |   |   |   |    |   |   |   |    |
|---|---|---|---|----|---|---|---|----|
| L | 1 | 2 | 4 | 2' | 1 | 2 | 4 | 2' |
| 0 |   |   |   |    | ● | ● | ● | ●  |
| 1 | ● |   |   |    |   |   |   |    |
| 2 |   | ● |   |    |   | ● |   | ●  |
| 3 | ● | ● |   |    |   |   | ● | ●  |
| 4 |   |   | ● |    |   |   | ● |    |
| 5 | ● | ● | ● |    |   | ● | ● | ●  |
| 6 |   | ● | ● | ●  |   |   |   | ●  |
| 7 | ● | ● | ● |    |   | ● | ● | ●  |
| 8 |   | ● | ● | ●  |   |   |   | ●  |
| 9 | ● | ● | ● | ●  |   | ● | ● | ●  |

**S01**

1 or 2 Pole 2 Throw  
Common (C1) and (C2) connected to terminals indicated

|      |    |    |    |
|------|----|----|----|
|      |    | C1 | C2 |
| DIAL | A1 | B1 | B2 |
| 0    | 0  | +  | ●  |
| 1    | 5  | -  | ●  |
| 2    | 0  | 0  | +  |
| 3    | 5  | 1  | -  |
| 4    | 0  | 0  | +  |
| 5    | 5  | 1  | -  |
| 6    | 0  | 0  | +  |
| 7    | 5  | 1  | -  |
| 8    | 0  | 0  | +  |
| 9    | 5  | 1  | -  |

**S03**

5-Line TELETYPE  
1 Pole 10 Position

D I A L Common (C) connected to terminals indicated

|   |   |   |   |   |   |
|---|---|---|---|---|---|
| L | 1 | 2 | 3 | 4 | 5 |
| 0 | ● | ● | ● | ● | ● |
| 1 | ● | ● | ● | ● | ● |
| 2 | ● | ● | ● | ● | ● |
| 3 | ● | ● | ● | ● | ● |
| 4 | ● | ● | ● | ● | ● |
| 5 | ● | ● | ● | ● | ● |
| 6 | ● | ● | ● | ● | ● |
| 7 | ● | ● | ● | ● | ● |
| 8 | ● | ● | ● | ● | ● |
| 9 | ● | ● | ● | ● | ● |

**S04**

5-Line TELETYPE w/even bit parity  
1 Pole 10 Position

D I A L Common (C) connected to terminals indicated

|   |   |   |   |   |   |   |
|---|---|---|---|---|---|---|
| L | 1 | 2 | 3 | 4 | 5 | P |
| 0 | ● | ● | ● | ● | ● | ● |
| 1 | ● | ● | ● | ● | ● | ● |
| 2 | ● | ● | ● | ● | ● | ● |
| 3 | ● | ● | ● | ● | ● | ● |
| 4 | ● | ● | ● | ● | ● | ● |
| 5 | ● | ● | ● | ● | ● | ● |
| 6 | ● | ● | ● | ● | ● | ● |
| 7 | ● | ● | ● | ● | ● | ● |
| 8 | ● | ● | ● | ● | ● | ● |
| 9 | ● | ● | ● | ● | ● | ● |

**S05**

BIQUINARY  
1 Pole 10 Position

D I A L Common (C) connected to terminals indicated

|   |     |      |   |   |   |   |   |   |   |   |   |   |
|---|-----|------|---|---|---|---|---|---|---|---|---|---|
| L | ODD | EVEN | 0 | 1 | 2 | 3 | 4 | 5 | 6 | 7 | 8 | 9 |
| 0 |     | ●    | ● |   |   |   |   |   |   |   |   |   |
| 1 | ●   |      | ● |   |   |   |   |   |   |   |   |   |
| 2 |     | ●    |   | ● |   |   |   |   |   |   |   |   |
| 3 | ●   |      | ● |   |   |   |   |   |   |   |   |   |
| 4 |     | ●    |   | ● |   |   |   |   |   |   |   |   |
| 5 | ●   |      | ● |   |   |   |   |   |   |   |   |   |
| 6 |     | ●    |   | ● |   |   |   |   |   |   |   |   |
| 7 | ●   |      | ● |   |   |   |   |   |   |   |   |   |
| 8 |     | ●    |   | ● |   |   |   |   |   |   |   |   |
| 9 | ●   |      | ● |   |   |   |   |   |   |   |   |   |

**S06**

NOT/NOR SWITCH 1 Pole 12 Position  
(All Positions Shorted except Position indicated on Dial)

D I A L Common (C) connected to terminals indicated

|    |   |   |   |   |   |   |   |   |   |   |    |    |
|----|---|---|---|---|---|---|---|---|---|---|----|----|
| L  | 0 | 1 | 2 | 3 | 4 | 5 | 6 | 7 | 8 | 9 | 10 | 11 |
| 0  | ● | ● | ● | ● | ● | ● | ● | ● | ● | ● | ●  | ●  |
| 1  | ● | ● | ● | ● | ● | ● | ● | ● | ● | ● | ●  | ●  |
| 2  | ● | ● | ● | ● | ● | ● | ● | ● | ● | ● | ●  | ●  |
| 3  | ● | ● | ● | ● | ● | ● | ● | ● | ● | ● | ●  | ●  |
| 4  | ● | ● | ● | ● | ● | ● | ● | ● | ● | ● | ●  | ●  |
| 5  | ● | ● | ● | ● | ● | ● | ● | ● | ● | ● | ●  | ●  |
| 6  | ● | ● | ● | ● | ● | ● | ● | ● | ● | ● | ●  | ●  |
| 7  | ● | ● | ● | ● | ● | ● | ● | ● | ● | ● | ●  | ●  |
| 8  | ● | ● | ● | ● | ● | ● | ● | ● | ● | ● | ●  | ●  |
| 9  | ● | ● | ● | ● | ● | ● | ● | ● | ● | ● | ●  | ●  |
| 10 | ● | ● | ● | ● | ● | ● | ● | ● | ● | ● | ●  | ●  |
| 11 | ● | ● | ● | ● | ● | ● | ● | ● | ● | ● | ●  | ●  |

**S07**

INCREMENTAL Voltage Divider  
2 Pole 10 Position

D I A L Pins 1 and 2 connected across resistor indicated

|   |    |    |    |    |    |    |    |    |    |    |
|---|----|----|----|----|----|----|----|----|----|----|
| L | R0 | R1 | R2 | R3 | R4 | R5 | R6 | R7 | R8 | R9 |
| 0 | ●  |    |    |    |    |    |    |    |    |    |
| 1 |    | ●  |    |    |    |    |    |    |    |    |
| 2 |    |    | ●  |    |    |    |    |    |    |    |
| 3 |    |    |    | ●  |    |    |    |    |    |    |
| 4 |    |    |    |    | ●  |    |    |    |    |    |
| 5 |    |    |    |    |    | ●  |    |    |    |    |
| 6 |    |    |    |    |    |    | ●  |    |    |    |
| 7 |    |    |    |    |    |    |    | ●  |    |    |
| 8 |    |    |    |    |    |    |    |    | ●  |    |
| 9 |    |    |    |    |    |    |    |    |    | ●  |

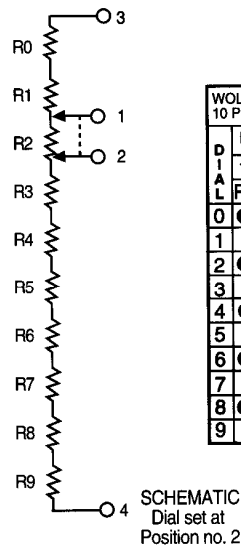

**S08**

WOLFF POGGENDORF Voltage Divider  
10 Position

D I A L Resistors in circuit

|   |   |   |   |    |   |   |   |    |
|---|---|---|---|----|---|---|---|----|
| L | 1 | 2 | 4 | 2' | 1 | 2 | 4 | 2' |
| 0 | ● | ● | ● |    |   |   |   | ●  |
| 1 |   | ● | ● | ●  |   |   |   | ●  |
| 2 | ● |   | ● | ●  | ● |   |   | ●  |
| 3 |   | ● | ● | ●  | ● | ● |   | ●  |
| 4 | ● | ● | ● | ●  | ● | ● |   | ●  |
| 5 |   | ● | ● | ●  | ● | ● | ● | ●  |
| 6 | ● | ● | ● | ●  | ● | ● | ● | ●  |
| 7 |   | ● | ● | ●  | ● | ● | ● | ●  |
| 8 | ● | ● | ● | ●  | ● | ● | ● | ●  |
| 9 |   | ● | ● | ●  | ● | ● | ● | ●  |

**S09**

CAPACITOR DECADE  
1-2-3-4 Code 10 Position

D I A L Capacitors in Circuit

|   |    |    |    |    |
|---|----|----|----|----|
| L | C1 | C2 | C3 | C4 |
| 0 |    |    |    |    |
| 1 | ●  |    |    |    |
| 2 |    | ●  |    |    |
| 3 |    |    | ●  |    |
| 4 |    |    |    | ●  |
| 5 | ●  | ●  | ●  | ●  |
| 6 | ●  | ●  | ●  | ●  |
| 7 | ●  | ●  | ●  | ●  |
| 8 | ●  | ●  | ●  | ●  |
| 9 | ●  | ●  | ●  | ●  |

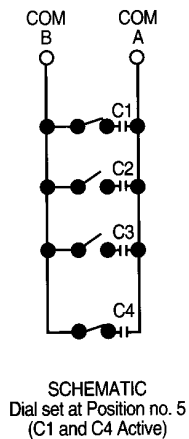

**S10**  
RESISTOR DECADE  
1-2-3-6 Code 10 Position

|      |                      |    |    |    |   |  |
|------|----------------------|----|----|----|---|--|
| DIAL | Resistors in circuit |    |    |    |   |  |
| L    | R1                   | R2 | R3 | R6 |   |  |
| 0    | ●                    |    |    |    |   |  |
| 1    |                      | ●  |    |    |   |  |
| 2    |                      |    | ●  |    |   |  |
| 3    |                      |    |    | ●  |   |  |
| 4    | ●                    |    |    |    |   |  |
| 5    |                      | ●  |    |    |   |  |
| 6    |                      |    | ●  |    |   |  |
| 7    | ●                    |    |    |    |   |  |
| 8    |                      |    |    | ●  |   |  |
| 9    |                      |    |    |    | ● |  |

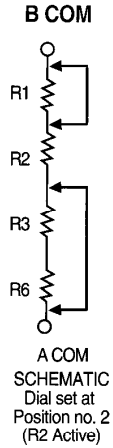

**S11**  
7 BAR INDICATOR  
1 Pole 10 Position

|      |   |   |   |   |   |   |   |
|------|---|---|---|---|---|---|---|
| DIAL | Common connected to terminals indicated |   |   |   |   |   |   |
| L    | A                                       | B | C | D | E | F | G |
| 0    | ●                                       |   |   | ● | ● | ● | ● |
| 1    | ●                                       | ● |   |   |   |   |   |
| 2    | ●                                       |   |   |   |   |   |   |
| 3    |   | ● | ● | ● | ● | ● | ● |
| 4    |   |   | ● | ● | ● | ● | ● |
| 5    |   |   |   | ● | ● | ● | ● |
| 6    | ●                                       | ● | ● | ● | ● | ● | ● |
| 7    |   |   |   |   |   |   |   |
| 8    | ●                                       | ● | ● | ● | ● | ● | ● |
| 9    | ●                                       | ● | ● | ● | ● | ● | ● |

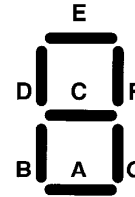

**S12**  
KELVIN VARLEY: Voltage Divider  
10 Position

|      |   |    |    |    |    |    |    |    |    |    |     |
|------|---|----|----|----|----|----|----|----|----|----|-----|
| DIAL | Pins 1 and 2 connected across resistors indicated |    |    |    |    |    |    |    |    |    |     |
| L    | R0  | R1 | R2 | R3 | R4 | R5 | R6 | R7 | R8 | R9 | R10 |
| 0    | ●   | ●  |    |    |    |    |    |    |    |    |     |
| 1    |   | ●  | ●  |    |    |    |    |    |    |    |     |
| 2    |   |    | ●  | ●  |    |    |    |    |    |    |     |
| 3    |   |    |    | ●  | ●  |    |    |    |    |    |     |
| 4    |   |    |    |    | ●  | ●  |    |    |    |    |     |
| 5    |   |    |    |    |    | ●  | ●  |    |    |    |     |
| 6    |   |    |    |    |    |    | ●  | ●  |    |    |     |
| 7    |   |    |    |    |    |    |    | ●  | ●  |    |     |
| 8    |   |    |    |    |    |    |    |    | ●  | ●  |     |
| 9    |   |    |    |    |    |    |    |    |    | ●  | ●   |

**S15**  
Modified 5 Bit TELETYPE  
1-2-4-2' Code 10 Position

|      |   |   |   |   |   |
|------|---|---|---|---|---|
| DIAL | Common (C) connected to terminals indicated |   |   |   |   |
| L    | 1   | 2 | 3 | 4 | 5 |
| 0    |   | ● | ● | ● | ● |
| 1    |   | ● | ● | ● | ● |
| 2    | ●   |   |   |   | ● |
| 3    | ●   |   |   |   | ● |
| 4    | ●   | ● |   | ● |   |
| 5    | ●   |   |   |   | ● |
| 6    | ●   |   | ● |   | ● |
| 7    | ●   | ● |   |   | ● |
| 8    | ●   |   |   |   | ● |
| 9    |   |   |   | ● | ● |

**S17**  
Resistor DECADE  
1-2-4-2' Code 10 Position

|      |                      |    |    |     |  |
|------|----------------------|----|----|-----|--|
| DIAL | Resistors in circuit |    |    |     |  |
| L    | R1                   | R2 | R4 | R2' |  |
| 0    |                      |    |    |     |  |
| 1    | ●                    |    |    |     |  |
| 2    | ●                    | ●  |    |     |  |
| 3    | ●                    | ●  |    |     |  |
| 4    |                      |    | ●  |     |  |
| 5    | ●                    | ●  |    |     |  |
| 6    | ●                    | ●  |    |     |  |
| 7    | ●                    | ●  |    |     |  |
| 8    | ●                    | ●  |    |     |  |
| 9    | ●                    | ●  |    |     |  |

**S18**  
Resistor DECADE  
1-2-2-2-2 Code 10 Position

|      |                      |    |    |    |    |
|------|----------------------|----|----|----|----|
| DIAL | Resistors in circuit |    |    |    |    |
| L    | R1                   | R2 | R3 | R4 | R5 |
| 0    |                      |    |    |    |    |
| 1    | ●                    |    |    |    |    |
| 2    |                      |    |    |    | ●  |
| 3    | ●                    |    |    |    |    |
| 4    |                      |    |    |    | ●  |
| 5    | ●                    | ●  | ●  | ●  | ●  |
| 6    |                      |    | ●  | ●  | ●  |
| 7    | ●                    | ●  | ●  | ●  | ●  |
| 8    |                      |    | ●  | ●  | ●  |
| 9    | ●                    | ●  | ●  | ●  | ●  |

**S19**  
2 Pole 2 Throw

|  |           |   |
|--|-----------|---|
| Commons C(●) and C(*) connected to terminals indicated |           |   |
| DIAL   | A         | B |
| 0  | 0 + ● ★   | ● |
| 1  | 5 - ★ ●   | ● |
| 2  | 0 0 + ● ★ | ● |
| 3  | 1 5 - ★ ● | ● |
| 4  | 0 0 + ● ★ | ● |
| 5  | 1 5 - ★ ● | ● |
| 6  | 0 0 + ● ★ | ● |
| 7  | 1 5 - ★ ● | ● |
| 8  | 0 0 + ● ★ | ● |
| 9  | 1 5 - ★ ● | ● |

**S20**  
2 Pole 1-1'-2-5 with Complement

|      |   |   |    |   |   |   |    |
|------|---|---|----|---|---|---|----|
| DIAL | Commons (C) and (C') connected to terminals indicated |   |    |   |   |   |    |
| L    | 5   | 2 | 1' | 1 | 5 | 2 | 1' |
| 0    |   |   |    | ● | ● | ● | ●  |
| 1    |   |   |    | ● | ● | ● | ●  |
| 2    | ●   |   |    |   |   |   |    |
| 3    | ●   | ● | ●  |   |   |   |    |
| 4    | ●   | ● | ●  |   |   |   |    |
| 5    |   |   |    | ● | ● | ● | ●  |
| 6    | ●   | ● | ●  |   |   |   |    |
| 7    | ●   | ● | ●  |   |   |   |    |
| 8    | ●   | ● | ●  |   |   |   |    |
| 9    | ●   | ● | ●  |   |   |   |    |

**S21**  
ECCO Voltage Divider (THUMB POT)  
10 Position

|      |   |    |    |    |  |    |    |    |
|------|---|----|----|----|--|----|----|----|
| DIAL | Resistors in circuit between term 2 & 5 |    |    |    | Resistors in circuit between term 8 & 11 |    |    |    |
| L    | 4                                       | 2  | 1  | 2' | 4  | 2  | 1  | 2' |
|      | R1                                      | R2 | R3 | R4 | R1                                       | R2 | R3 | R4 |
| 0    |   |    |    |    | ●  | ●  | ●  | ●  |
| 1    |   |    |    |    | ●  | ●  | ●  | ●  |
| 2    | ●                                       |    |    |    |  |    |    |    |
| 3    | ●                                       | ●  | ●  | ●  |  |    |    |    |
| 4    | ●                                       | ●  | ●  | ●  |  |    |    |    |
| 5    | ●                                       |    |    |    | ●  | ●  | ●  | ●  |
| 6    | ●                                       | ●  | ●  | ●  |  |    |    |    |
| 7    | ●                                       | ●  | ●  | ●  |  |    |    |    |
| 8    | ●                                       | ●  | ●  | ●  |  |    |    |    |
| 9    | ●                                       | ●  | ●  | ●  |  |    |    |    |

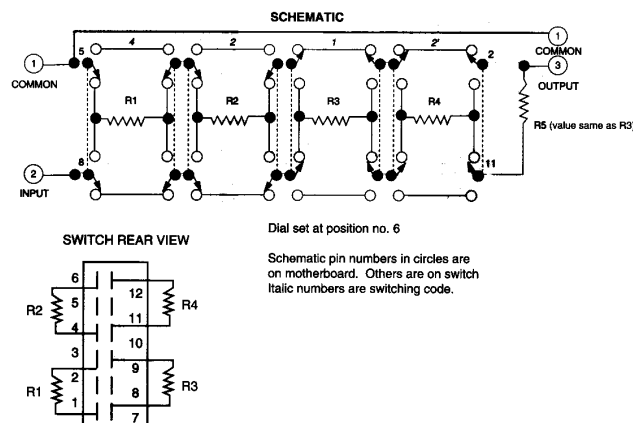

**S22**  
1-2-4-5 Code

|      |   |   |   |   |  |
|------|---|---|---|---|--|
| DIAL | Common (C) connected to terminals indicated |   |   |   |  |
| L    | 1   | 2 | 4 | 5 |  |
| 0    |   |   |   |   |  |
| 1    | ●   |   |   |   |  |
| 2    | ●   | ● |   |   |  |
| 3    | ●   | ● |   |   |  |
| 4    |   |   | ● |   |  |
| 5    |   |   |   | ● |  |
| 6    | ●   | ● |   |   |  |
| 7    | ●   | ● |   |   |  |
| 8    | ●   | ● |   |   |  |
| 9    | ●   | ● |   |   |  |

**S23**  
JOHNSON CODE

|      |   |   |   |   |   |
|------|---|---|---|---|---|
| DIAL | Common (C) connected to terminals indicated |   |   |   |   |
| L    | A   | B | C | D | E |
| 0    | ●   | ● | ● | ● | ● |
| 1    | ●   | ● | ● | ● | ● |
| 2    | ●   | ● | ● | ● | ● |
| 3    | ●   | ● | ● | ● | ● |
| 4    |   |   |   |   |   |
| 5    |   |   |   |   |   |
| 6    |   |   |   |   |   |
| 7    |   |   |   |   |   |
| 8    |   |   |   |   |   |
| 9    |   |   |   |   |   |

Consult factory for additional information.



# EECO® 7000 SERIES THUMBWHEEL SWITCHES

*The 7000 Series combines heavy-duty construction and a compact package size.*

Designed to meet demanding military performance specifications, the *7000 Series* switch features a unique one-piece housing design to permanently seal the contacts from moisture, dirt, and dust. The *7000 Series* is available in either P.C. board or flexible cable termination styles, and in a variety of decimal or binary output codes. Optional features include lighted legends, EMI/RFI shielding and a doublewide message unit. Lamps are easily replaced without tools on lighted models. Typical applications include military and commercial aircraft, shipboard, and harsh industrial environments. The *7000 Series* is backed by EECO's one-year warranty.



## SPECIFICATIONS

### MECHANICAL

|                                  |  |                   |
|----------------------------------|--|-------------------|
| No. of Switching Positions       | 8, 10, 12, 16  |                   |
| Temperature Life Characteristics | Rotational Cycles                                      | Temperature Range |
| Unlighted                        | 50,000   | -65°C To +85°C    |
| Lighted                          | 50,000   | -65°C To +71°C    |
| Tangential Operating Force       | 8,10 and 12 Position 6-20 Oz.<br>16 Position: 6-24 Oz. |                   |
| Weight                           | 0.40 Oz.(Approx.)                                      |                   |
| Stop Strength (When Applicable)  | 5 Lbs.   |                   |

### ELECTRICAL

|   |                             |
|---|-----------------------------|
| Maximum Electrical Current, Non-Switching                 | 3A Per Common Terminal      |
| Maximum Rated Load, Switching                             | 125 mA at 28 VDC or 115 VAC |
| Circuit Resistance (Excluding Cable)                      |                             |
| Initial   | 100 mΩ Maximum              |
| After Life  | 1Ω Maximum                  |
| Insulation Resistance                                     | 1,000 MΩ Minimum            |
| Dielectric Withstanding Voltage (At Atmospheric Pressure) |                             |
| 8, 10, 12 Position  | 750 VAC (RMS)               |
| 16 Position   | 500 VAC (RMS)               |

### ENVIRONMENTAL

|               |                     |
|---------------|---------------------|
| Vibration     | 15 G's, 10-2,000 Hz |
| Shock         | 100 G's             |
| Salt Spray    | 48 Hrs.             |
| Humidity      | 10 Days             |
| Thermal Shock | -65°C To +85°C      |
| Altitude      | 70,000 Ft.          |
| Seal          | 10 +/- 1 PSIG       |
| Acceleration  | 20 G's              |

### MATERIALS

|                           |  |
|---------------------------|--|
| Plastic                   | Polycarbonate per Federal Spec LP-393A |
| Metals                    | Corrosion Resistant                    |
| O-Ring                    | Buna-N                                 |
| Circuit Boards - Material | Glass Epoxy per MIL-P-13949 Type GF    |
| Plating                   | Gold Over Nickel Plating Per MIL-45204 |
| Contacts                  | Copper Alloy, Gold Over Nickel Plating |
| Cable                     | Per MIL-W-16878 Type B                 |



# 7000 Series

## OUTLINE DIMENSIONS

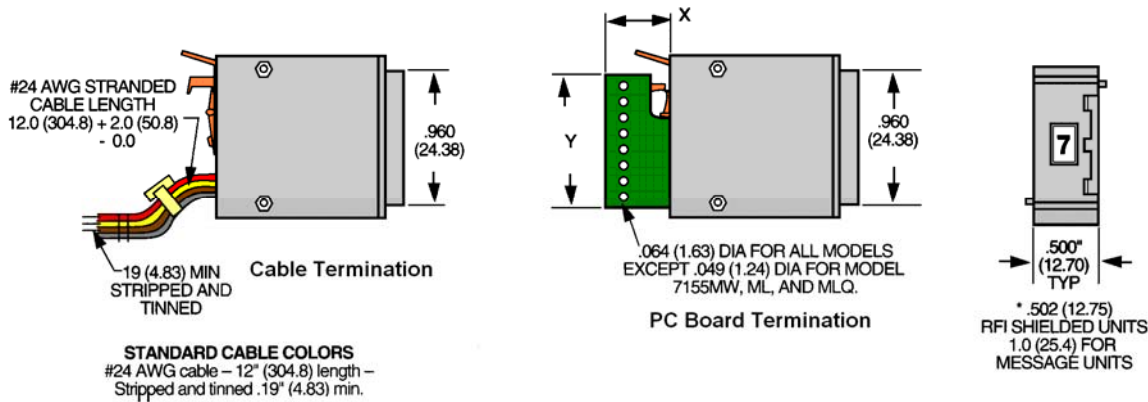

| Cable Color Code | TRUTH TABLE |         |         |     |     |         |     |
|------------------|-------------|---------|---------|-----|-----|---------|-----|
|                  | A02         | B02 B07 | C02 C04 | C12 | D01 | D02 D06 | E01 |
| White/Brown      | C           | C       | C       | C   |     | X       | C   |
| White/Orange     |             |         |         |     |     | Y       | C   |
| White/Black      |             |         |         |     |     | Y       | C   |
| Black            | 0           |         | 1       | 8   | Y   |         |     |
| Brown            | 1           | 1       | 1       |     | 1   | 1       | 1   |
| Red              | 2           | 2       | 2       |     | 2   | 2       | 2   |
| Orange           | 3           |         | 4       | 4   |     | 4       | 4   |
| Yellow           | 4           | 4       | 4       |     | 4   | 4       | 4   |
| Green            | 5           |         |         |     |     |         |     |
| Blue             | 6           |         | 1       | 1   |     |         | 1   |
| Violet           | 7           |         | 2       | 2   |     |         | 2   |
| Gray             | 8           | 8       | 8       |     |     | 8       |     |
| White            | 9           |         |         |     | X   |         |     |

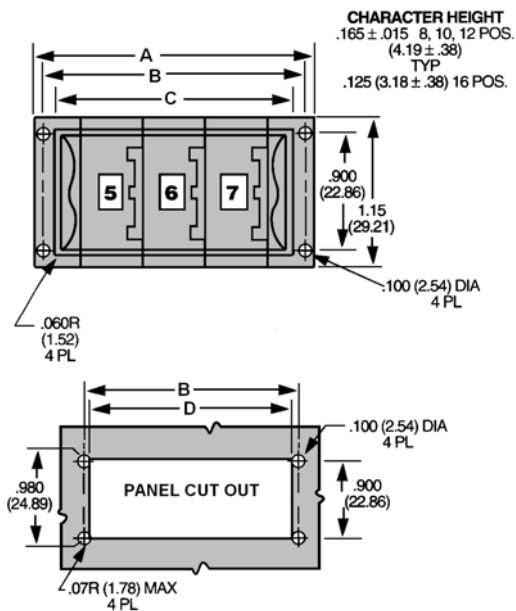
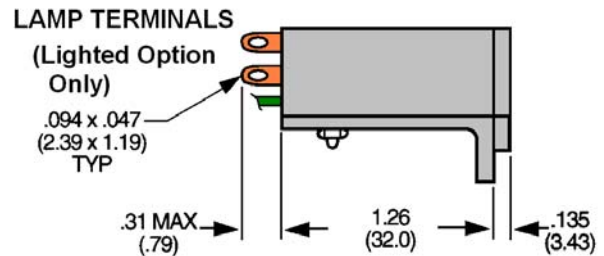

| MOUNTING DIMENSIONS |                        |              |              |              |                            |               |
|---------------------|------------------------|--------------|--------------|--------------|----------------------------|---------------|
| No. Of Stations     | STANDARD SWITCH MODELS |              |              |              | W/RFI SHIELDING (Option U) |               |
|                     | A                      | B            | C            | D            | B                          | D             |
| 1                   | 1.26 (32.0)            | 1.09 (27.7)  | 0.90 (22.9)  | 0.92 (23.4)  | 1.094 (27.8)               | 0.926 (23.5)  |
| 2                   | 1.76 (44.7)            | 1.59 (40.4)  | 1.40 (35.6)  | 1.42 (36.1)  | 1.596 (40.5)               | 1.428 (36.3)  |
| 3                   | 2.26 (57.4)            | 2.09 (53.1)  | 1.90 (48.3)  | 1.92 (48.8)  | 2.098 (53.3)               | 1.930 (49.0)  |
| 4                   | 2.76 (70.1)            | 2.59 (65.8)  | 2.40 (61.0)  | 2.42 (61.5)  | 2.600 (66.0)               | 2.432 (61.8)  |
| 5                   | 3.26 (82.8)            | 3.09 (78.5)  | 2.90 (73.7)  | 2.92 (74.2)  | 3.102 (78.8)               | 2.934 (74.5)  |
| 6                   | 3.76 (95.5)            | 3.59 (91.2)  | 3.40 (86.4)  | 3.42 (86.9)  | 3.604 (91.5)               | 3.436 (87.3)  |
| 7                   | 4.26 (108.2)           | 4.09 (103.9) | 3.90 (99.1)  | 3.92 (99.6)  | 4.106 (104.3)              | 3.938 (100.0) |
| 8                   | 4.76 (120.9)           | 4.59 (116.6) | 4.40 (111.8) | 4.42 (112.3) | 4.608 (117.0)              | 4.440 (112.8) |
| 9                   | 5.26 (133.6)           | 5.09 (129.3) | 4.90 (124.5) | 4.92 (125.0) | 5.110 (129.8)              | 4.942 (125.5) |
| 10                  | 5.76 (146.3)           | 5.59 (142.0) | 5.40 (137.2) | 5.42 (137.7) | 5.612 (142.5)              | 5.444 (138.3) |

Tolerances: .XXX ± 0.010" .XX ± 0.030" unless otherwise noted.  
 Assembly may exhibit an expansion of .003" per station before installation but will adjust to recommended panel cutout when installed.

Spacers count as stations. Subtract .250" from each dimension A through D when spacers are used.  
 Add .500" to dimensions A through D for each additional station over 10.

( ) Metric equivalents in mm



## STANDARD SWITCH MODELS

| TRUTH<br>TABLE               | PART<br>NUMBER | PART<br>DESCRIPTION                                   | NO. OF<br>POSITIONS | PCB TAIL DIMS   |                 | TYPE  |
|------------------------------|----------------|---|---------------------|-----------------|-----------------|-------|
|                              |                |   |                     | X               | Y               |       |
| <b>DECIMAL SWITCHES</b>      |                |   |                     |                 |                 |       |
| A02                          | 7151MW         | 1 Pole Decimal  | 10                  | 0.385<br>(9.8)  | 1.200<br>(30.5) | PCB   |
| A02                          | 7251MW         | 1 Pole Decimal  | 10                  |                 |                 | Cable |
| <b>BINARY CODED SWITCHES</b> |                |   |                     |                 |                 |       |
| B02                          | 7154MW         | 1 Pole BCD  | 10                  | 0.385<br>(9.8)  | 1.200<br>(30.5) | PCB   |
| B02                          | 7254MW         | 1 Pole BCD  | 10                  |                 |                 | Cable |
| B02                          | 7354MW         | 1 Pole BCD Diode Provision                            | 10                  | 0.875<br>(22.2) | 1.146<br>(29.1) | PCB   |
| B07                          | 7158MW         | 1 Pole BCH Marked 0-9-A-F                             | 16                  | 0.385<br>(9.8)  | 0.950<br>(24.1) | PCB   |
| B07                          | 7162MW         | 1 Pole BCH Marked 0-15                                | 16                  | 0.385<br>(9.8)  | 0.950<br>(24.1) | PCB   |
| C02                          | 7156MW         | 1 Pole BCD w/Complement                               | 10                  | 0.385<br>(9.8)  | 1.146<br>(29.1) | PCB   |
| C02                          | 7256MW         | 1 Pole BCD w/Complement                               | 10                  |                 |                 | Cable |
| C02                          | 7356MW         | 1 Pole BCD w/Complement Diode Provision               | 10                  | 0.875<br>(22.2) | 1.146<br>(29.1) | PCB   |
| C04                          | 7257MW         | 1 Pole 12 Position BCD w/Complement                   | 12                  |                 |                 | Cable |
| C12                          | 7261MW         | 1 Pole BCD Complement Only                            | 10                  |                 |                 | Cable |
| D01                          | 7152MW         | 2 Pole BCO w/Separate Common To Not True Bits         | 8                   | 0.385<br>(9.8)  | 0.950<br>(24.1) | PCB   |
| D01                          | 7252MW         | 2 Pole BCO w/Separate Common To Not True Bits         | 8                   |                 |                 | Cable |
| D02                          | 7155MW         | 2 Pole BCD w/Separate Common To Not True Bits         | 10                  | 0.385<br>(9.8)  | 0.950<br>(24.1) | PCB   |
| D02                          | 7255MW         | 2 Pole BCD w/Separate Common To Not True Bits         | 10                  |                 |                 | Cable |
| D06                          | 7159MW         | 2 Pole BCH w/Separate Common to Not True Bits 0-9-A-F | 16                  | 0.385<br>(9.8)  | 0.950<br>(24.1) | PCB   |
| D06                          | 7163MW         | 2 Pole BCH w/Separate Common to Not True Bits 0-15    | 16                  | 0.385<br>(9.8)  | 0.950<br>(24.1) | PCB   |
| E01                          | 7153MW         | 2 Pole BCO w/Complement                               | 8                   | 0.385<br>(9.8)  | 0.950<br>(24.1) | PCB   |
| E01                          | 7253MW         | 2 Pole BCO w/Complement                               | 8                   |                 |                 | Cable |
| E01                          | 7353MW         | 2 Pole BCO w/Complement Diode Provision               | 8                   | 0.875<br>(22.2) | 1.146<br>(29.1) | PCB   |
| S01                          | 7160MW         | 1 Pole Repeating Marked +/-                           | 10                  | 0.385<br>(9.8)  | 0.950<br>(24.1) | PCB   |

Metric equivalents ( ) in mm. Consult factory for other codes and options.

## RoHS COMPLIANCE

Eeco Switch is fully committed to complying with the European Lead-Free and RoHS directives. The 7000 Series is Lead-Free and RoHS compliant.



# 7000 Series

## AVAILABLE OPTIONS

- A Diodes Installed Anode To Common
  - C Diodes Installed Cathode To Common
  - D Decimal Point (Stamped)
  - K Lighted Decimal Point (Spacer Only)
  - L Lighted Switch Legend. Illuminated White Character On Black Background. 5 Volt Lamp Standard, Consult Factory For Other Voltages. N/A Double Wide Units
  - M Spray Matte Finish (Standard)
  - P +/- Rotor Marking
  - Q Aviation Red Lighting. Also Requires Option L
  - T Alphabet Marking
  - U EMI/RFI Shielding. Factory Assembled Only.
- Stop Pins  
Consult Factory for Custom Rotor Marking, Double Wide Switch Modules, Custom Output Codes and Other Special Requests

## 7000 HARDWARE AND ACCESSORIES

**70SM-X** Standard Hardware Kit: Endpieces, Threaded Rods, Screws, Nuts and Washers

**NOTE: REPLACE "X" IN HARDWARE KIT PART NUMBER WITH THE APPROPRIATE NUMBER OF SWITCHES AND SPACERS IN THE ASSEMBLY**

| CATALOG NUMBER | PART NUMBER | DESCRIPTION        |
|----------------|-------------|--------------------|
| E70SM          | 235446-02   | Endpiece, Matte    |
| S70SM          | 193263-00   | .250" Spacer Matte |

### ORDERING EXAMPLE - SWITCH

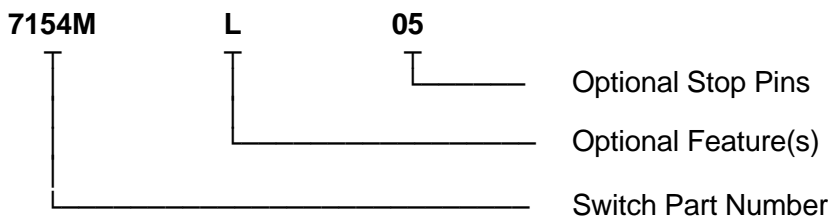

### ORDERING EXAMPLE - ASSEMBLY

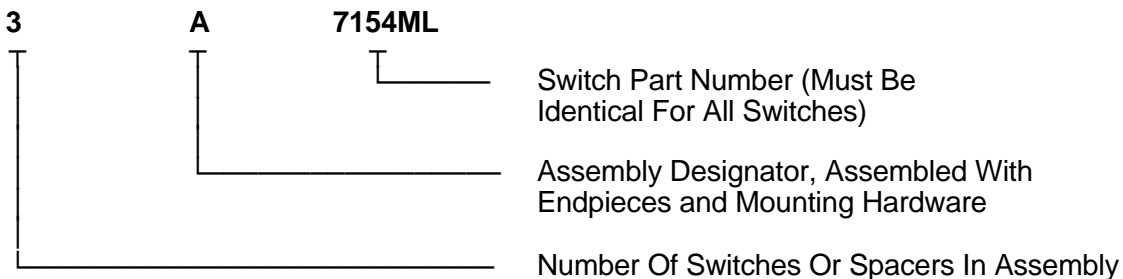

Assemblies of mixed switches and/or certain options require a special assembly number. Consult factory for additional ordering information.



TRUTH TABLES

A02

| DECIMAL 1 Pole 10 Position |                           |   |   |   |   |   |   |   |   |   |
|----------------------------|---------------------------|---|---|---|---|---|---|---|---|---|
| D<br>I<br>A<br>L           | Common (C) Connected To ● |   |   |   |   |   |   |   |   |   |
|                            | 0                         | 1 | 2 | 3 | 4 | 5 | 6 | 7 | 8 | 9 |
| 0                          | ●                         |   |   |   |   |   |   |   |   |   |
| 1                          |                           | ● |   |   |   |   |   |   |   |   |
| 2                          |                           |   | ● |   |   |   |   |   |   |   |
| 3                          |                           |   |   | ● |   |   |   |   |   |   |
| 4                          |                           |   |   |   | ● |   |   |   |   |   |
| 5                          |                           |   |   |   |   | ● |   |   |   |   |
| 6                          |                           |   |   |   |   |   | ● |   |   |   |
| 7                          |                           |   |   |   |   |   |   | ● |   |   |
| 8                          |                           |   |   |   |   |   |   |   | ● |   |
| 9                          |                           |   |   |   |   |   |   |   |   | ● |

B02

| BCD 1 Pole 10 Position |                           |   |   |   |
|------------------------|---------------------------|---|---|---|
| D<br>I<br>A<br>L       | Common (C) Connected To ● |   |   |   |
|                        | 1                         | 2 | 4 | 8 |
| 0                      |                           |   |   |   |
| 1                      | ●                         |   |   |   |
| 2                      |                           | ● |   |   |
| 3                      | ●                         | ● |   |   |
| 4                      |                           |   | ● |   |
| 5                      | ●                         |   | ● |   |
| 6                      |                           | ● | ● |   |
| 7                      | ●                         | ● | ● |   |
| 8                      |                           |   |   | ● |
| 9                      | ●                         |   |   | ● |

B07

| HEXADECIMAL 1 Pole 16 Position |   |                           |   |   |   |
|--------------------------------|---|---------------------------|---|---|---|
| D<br>I<br>A<br>L               |   | Common (C) Connected To ● |   |   |   |
|                                |   | 1                         | 2 | 4 | 8 |
| 0                              | 0 |                           |   |   |   |
| 1                              | 1 | ●                         |   |   |   |
| 2                              | 2 |                           | ● |   |   |
| 3                              | 3 | ●                         | ● |   |   |
| 4                              | 4 |                           |   | ● |   |
| 5                              | 5 | ●                         |   | ● |   |
| 6                              | 6 |                           | ● | ● |   |
| 7                              | 7 | ●                         | ● | ● |   |
| 8                              | 8 |                           |   |   | ● |
| 9                              | 9 | ●                         |   |   | ● |
| 10                             | A |                           | ● |   | ● |
| 11                             | B | ●                         | ● |   | ● |
| 12                             | C |                           |   | ● | ● |
| 13                             | D | ●                         |   | ● | ● |
| 14                             | E |                           | ● | ● | ● |
| 15                             | F | ●                         | ● | ● | ● |

C02

| BCD w/Complement 1 Pole 10 Position |                           |   |   |   |   |   |   |   |
|-------------------------------------|---------------------------|---|---|---|---|---|---|---|
| D<br>I<br>A<br>L                    | Common (C) Connected To ● |   |   |   |   |   |   |   |
|                                     | 1                         | 2 | 4 | 8 | 1 | 2 | 4 | 8 |
| 0                                   |                           |   |   |   | ● | ● | ● | ● |
| 1                                   | ●                         |   |   |   |   | ● | ● | ● |
| 2                                   |                           | ● |   |   | ● |   | ● | ● |
| 3                                   | ●                         | ● |   |   |   |   | ● | ● |
| 4                                   |                           |   | ● |   | ● | ● |   | ● |
| 5                                   | ●                         |   | ● |   |   | ● |   | ● |
| 6                                   |                           | ● | ● |   | ● |   |   | ● |
| 7                                   | ●                         | ● | ● |   |   |   |   | ● |
| 8                                   |                           |   |   | ● | ● | ● | ● |   |
| 9                                   | ●                         |   |   | ● |   | ● | ● |   |

C04

| Binary Code w/Complement 1 Pole 12 Position |                           |   |   |   |   |   |   |   |
|---|---------------------------|---|---|---|---|---|---|---|
| D<br>I<br>A<br>L                            | Common (C) Connected To ● |   |   |   |   |   |   |   |
|   | 1                         | 2 | 4 | 8 | 1 | 2 | 4 | 8 |
| 0   |                           |   |   |   | ● | ● | ● | ● |
| 1   | ●                         |   |   |   |   | ● | ● | ● |
| 2   |                           | ● |   |   | ● |   | ● | ● |
| 3   | ●                         | ● |   |   |   |   | ● | ● |
| 4   |                           |   | ● |   | ● | ● |   | ● |
| 5   | ●                         |   | ● |   |   | ● |   | ● |
| 6   |                           | ● | ● |   | ● |   |   | ● |
| 7   | ●                         | ● | ● |   |   |   |   | ● |
| 8   |                           |   |   | ● | ● | ● | ● |   |
| 9   | ●                         |   |   | ● |   | ● | ● |   |
| 10  |                           | ● |   | ● | ● |   | ● |   |
| 11  | ●                         | ● |   | ● |   |   | ● |   |

C12

| BCD Complement 1 Pole 10 Position |                           |   |   |   |
|-----------------------------------|---------------------------|---|---|---|
| D<br>I<br>A<br>L                  | Common (C) Connected To ● |   |   |   |
|                                   | 1                         | 2 | 4 | 8 |
| 0                                 | ●                         | ● | ● | ● |
| 1                                 |                           | ● | ● | ● |
| 2                                 | ●                         |   | ● | ● |
| 3                                 |                           |   | ● | ● |
| 4                                 | ●                         | ● |   | ● |
| 5                                 |                           | ● |   | ● |
| 6                                 | ●                         |   |   | ● |
| 7                                 |                           |   |   | ● |
| 8                                 | ●                         | ● | ● |   |
| 9                                 |                           | ● | ● |   |



TRUTH TABLES

**D01**

| BCO w/Complement<br>2 Pole 8 Position |  |   |   |  |
|---------------------------------------|--|---|---|--|
| D<br>I<br>A<br>L                      | Commons (X) and (Y) Connected To ● and * |   |   |  |
|                                       | 1  | 2 | 4 |  |
| 0                                     | *  | * | * |  |
| 1                                     | ●  | * | * |  |
| 2                                     | *  | ● | * |  |
| 3                                     | ●  | ● | * |  |
| 4                                     | *  | * | ● |  |
| 5                                     | ●  | * | ● |  |
| 6                                     | *  | ● | ● |  |
| 7                                     | ●  | ● | ● |  |

**D02**

| BCD w/Complement<br>2 Pole 10 Position |  |   |   |   |  |
|--|--|---|---|---|--|
| D<br>I<br>A<br>L                       | Commons (X) and (Y) Connected To ● and * |   |   |   |  |
|  | 1  | 2 | 4 | 8 |  |
| 0                                      | *  | * | * | * |  |
| 1                                      | ●  | * | * | * |  |
| 2                                      | *  | ● | * | * |  |
| 3                                      | ●  | ● | * | * |  |
| 4                                      | *  | * | ● | * |  |
| 5                                      | ●  | * | ● | * |  |
| 6                                      | *  | ● | ● | * |  |
| 7                                      | ●  | ● | ● | * |  |
| 8                                      | *  | * | * | ● |  |
| 9                                      | ●  | * | * | ● |  |

**D06**

| HEXADECIMAL<br>2 Pole 16 Position |   |  |   |   |   |  |
|-----------------------------------|---|--|---|---|---|--|
| D<br>I<br>A<br>L                  |   | Commons (X) and (Y) Connected To ● and * |   |   |   |  |
|                                   |   | 1  | 2 | 4 | 8 |  |
| 0                                 | 0 | *  | * | * | * |  |
| 1                                 | 1 | ●  | * | * | * |  |
| 2                                 | 2 | *  | ● | * | * |  |
| 3                                 | 3 | ●  | ● | * | * |  |
| 4                                 | 4 | *  | * | ● | * |  |
| 5                                 | 5 | ●  | * | ● | * |  |
| 6                                 | 6 | *  | ● | ● | * |  |
| 7                                 | 7 | ●  | ● | ● | * |  |
| 8                                 | 8 | *  | * | * | ● |  |
| 9                                 | 9 | ●  | * | * | ● |  |
| 10                                | A | *  | ● | * | ● |  |
| 11                                | B | ●  | ● | * | ● |  |
| 12                                | C | *  | * | ● | ● |  |
| 13                                | D | ●  | * | ● | ● |  |
| 14                                | E | *  | ● | ● | ● |  |
| 15                                | F | ●  | ● | ● | ● |  |

**E02**

| BCD w/Complement<br>1 Pole 10 Position |                                   |   |   |   |   |   |   |   |  |
|--|-----------------------------------|---|---|---|---|---|---|---|--|
| D<br>I<br>A<br>L                       | Common (C) and (C) Connected To ● |   |   |   |   |   |   |   |  |
|  | 1                                 | 2 | 4 | 8 | 1 | 2 | 4 | 8 |  |
| 0                                      |                                   |   |   |   | ● | ● | ● | ● |  |
| 1                                      | ●                                 |   |   |   |   | ● | ● | ● |  |
| 2                                      |                                   | ● |   |   | ● |   | ● | ● |  |
| 3                                      | ●                                 | ● |   |   |   |   | ● | ● |  |
| 4                                      |                                   |   | ● |   | ● | ● |   | ● |  |
| 5                                      | ●                                 |   | ● |   |   | ● |   | ● |  |
| 6                                      |                                   | ● | ● |   | ● |   |   | ● |  |
| 7                                      | ●                                 | ● | ● |   |   |   |   | ● |  |
| 8                                      |                                   |   |   | ● | ● | ● | ● |   |  |
| 9                                      | ●                                 |   |   | ● |   | ● | ● |   |  |

**S01**

| A/B Repeating Code<br>Double Pole 10 Position |                                     |    |    |    |  |
|---|-------------------------------------|----|----|----|--|
| D<br>I<br>A<br>L                              | Common (C1) and (C2) Connected To ● |    |    |    |  |
|   | C1                                  |    | C2 |    |  |
|   | A1                                  | B1 | A2 | B2 |  |
| +   |                                     | ●  |    | ●  |  |
| -   | ●                                   |    | ●  |    |  |
| +   |                                     | ●  |    | ●  |  |
| -   | ●                                   |    | ●  |    |  |
| +   |                                     | ●  |    | ●  |  |
| -   | ●                                   |    | ●  |    |  |
| +   |                                     | ●  |    | ●  |  |
| -   | ●                                   |    | ●  |    |  |
| +   |                                     | ●  |    | ●  |  |
| -   | ●                                   |    | ●  |    |  |

EECO has a large library of special codes and options not listed in this document. Consult the factory with your special requirements.



# EECO® 1776/1976 SERIES THUMBWHEEL SWITCHES

*EECO's 1776 and 1976 Series thumbwheel switches are the standards of the industry. Both Series offer 8, 10, 12 or 16 position binary or decimal output codes for every possible application.*

The *1776 Series* is a standard .500" wide, while the *1976 Series* is .350" wide to save valuable front panel space. Optional notched terminals allow motherboards to be easily attached. The list of available options includes custom legends, lighting options, doublewide message units and fast-mount installation hardware. Many switch models offer mounting provisions for diodes. The *1776 and 1976 Series* both offer proven reliability at an economical price, and both are backed by EECO's one-year warranty.



## SPECIFICATIONS

### MECHANICAL

|                            |   |
|----------------------------|---|
| No. of Switching Positions | 8, 10, 12, 16                                   |
| Life                       | Minimum 1,000,000 Detents @ 10 mA, 5 VDC, +25°C |
| Tangential Operating Force | 1776 Series: 6-18 Oz., 1976 Series 5-16 Oz.     |
| Weight                     | 0.35 Oz.  |

### ELECTRICAL

|   |   |
|---|---|
| Maximum Electrical Current, Non-Switching | 3A Per Common Terminal  |
| Maximum Rated Load, Switching             | 125 mA at 28 VDC or 115 VAC   |
| Contact Resistance (Initial)              | 100 mΩ Maximum  |
| (After Life)                              | 200 mΩ Maximum  |
| Insulation Resistance                     | 1,000 MΩ Minimum At 100 VDC   |
| Dielectric Withstanding Voltage           | 1000 VAC (RMS) Single Pole Models<br>500 VAC (RMS) Double Pole Models |

### ENVIRONMENTAL

|                       |                 |
|-----------------------|-----------------|
| Operating Temperature | -20°C To +75°C  |
| Storage Temperature   | -40°C To +100°C |
| Seal                  | Dust Resistant  |

### MATERIALS

|                         |  |
|-------------------------|--|
| Plastic                 | Polycarbonate per Federal Spec LP-393A |
| Metals                  | Corrosion Resistant                    |
| Circuit Disc - Material | Glass Epoxy                            |
| Plating                 | Gold Over Nickel Plating               |
| Terminals               | Copper Alloy, Plated for Soldering     |
| Contacts                | Copper Alloy, Gold Over Nickel Plating |

### RoHS COMPLIANCE

EECO Switch is fully committed to complying with the European Lead-Free and RoHS directives. The 1776 and 1976 series are Lead Free and RoHS compliant.



# 1776/1976 Series

## OUTLINE DIMENSIONS

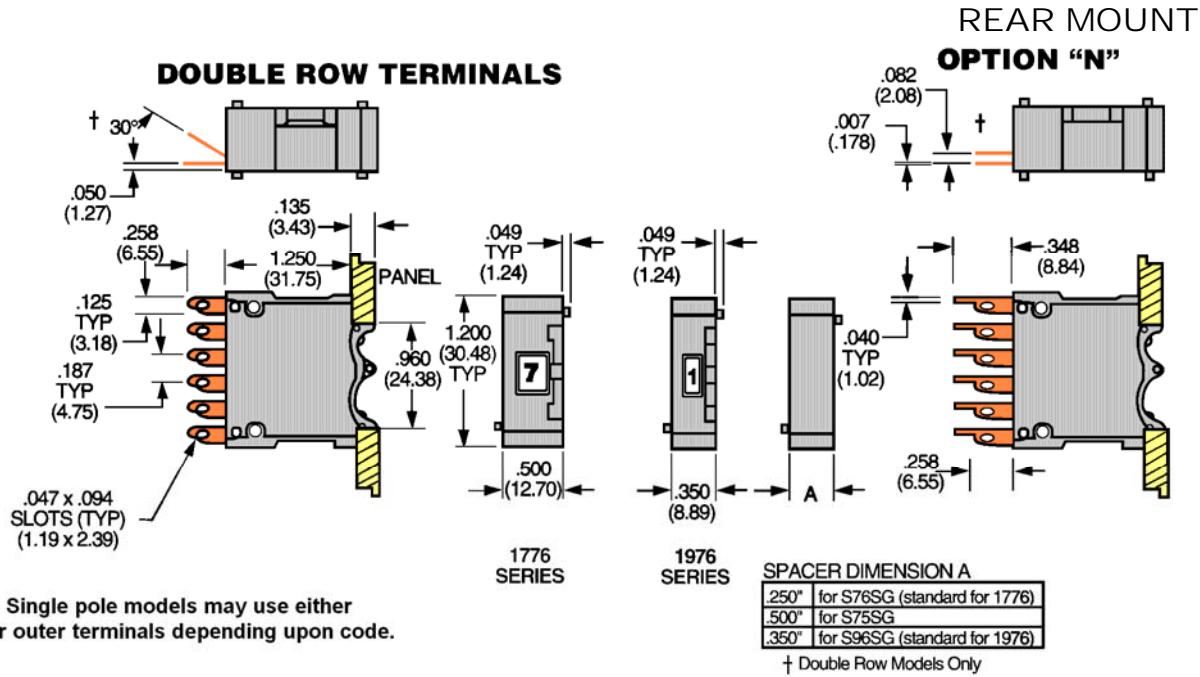

## 1776/1976 HARDWARE AND ACCESSORIES

- 77SG-X/97SG-X** Standard Hardware Kit: Endpieces, Threaded Rods, Screws, Nuts and Washers
- 78SG-X/98SG-X** Fast Mount Hardware Kit: Endpieces, Bezels Threaded Rods, Screws, Nuts and Washers (Option Y)

**NOTE:** REPLACE "G" WITH "M" TO ORDER SPRAY MATTE HARDWARE  
 REPLACE "X" WITH THE APPROPRIATE NUMBER OF SWITCHES IN ASSEMBLY

| SERIES    | CATALOG NUMBER | PART NUMBER | DESCRIPTION               |
|-----------|----------------|-------------|---------------------------|
| 1776/1976 | E76SG          | 195934-00   | Endpiece Gloss            |
| 1776/1976 | E76SM          | 195970-00   | Endpiece Matte            |
| 1776/1976 | Option Y       | 233658-01   | Fast Mount Endpiece Gloss |
| 1776/1976 | Option Y       | 233659-01   | Fast Mount Bezel Gloss    |
| 1776/1976 | Option Y       | 233659-02   | Fast Mount Bezel Matte    |
| 1776      | S75SG          | 233875-01   | .500" Spacer Gloss        |
| 1776      | S75SM          | 233875-02   | .500" Spacer Matte        |
| 1776      | S76SG          | 195954-00   | .250" Spacer Gloss        |
| 1776      | S76SM          | 195972-00   | .250" Spacer Matte        |
| 1976      | S96SG          | 234104-01   | .350" Spacer Gloss        |
| 1976      | S96SM          | 234104-03   | .350" Spacer Matte        |
| 1776      | SW7600DP       | 196992-01   | Diode/Resistor Module     |

PANEL MOUNTING INFORMATION

**1776 MODEL**

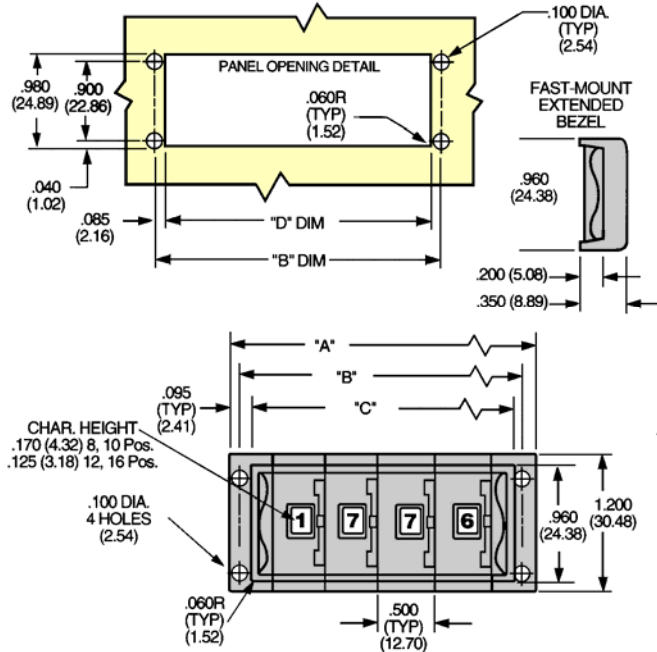

| NO. OF STATIONS | A               | B               | C               | D               |
|-----------------|-----------------|-----------------|-----------------|-----------------|
| 1               | 1.26<br>(32.0)  | 1.09<br>(27.7)  | 0.90<br>(22.9)  | 0.92<br>(23.4)  |
| 2               | 1.76<br>(44.7)  | 1.59<br>(40.4)  | 1.40<br>(35.6)  | 1.42<br>(36.1)  |
| 3               | 2.26<br>(57.4)  | 2.09<br>(53.1)  | 1.90<br>(48.3)  | 1.92<br>(48.8)  |
| 4               | 2.76<br>(70.1)  | 2.59<br>(65.8)  | 2.40<br>(61.0)  | 2.42<br>(61.5)  |
| 5               | 3.26<br>(82.8)  | 3.09<br>(78.5)  | 2.90<br>(73.7)  | 2.92<br>(74.2)  |
| 6               | 3.76<br>(95.5)  | 3.59<br>(91.2)  | 3.40<br>(86.4)  | 3.42<br>(86.9)  |
| 7               | 4.26<br>(108.2) | 4.09<br>(103.9) | 3.90<br>(99.1)  | 3.92<br>(99.6)  |
| 8               | 4.76<br>(120.9) | 4.59<br>(116.6) | 4.40<br>(111.8) | 4.42<br>(112.3) |
| 9               | 5.26<br>(133.6) | 5.09<br>(129.3) | 4.90<br>(124.5) | 4.92<br>(125.0) |
| 10              | 5.76<br>(146.3) | 5.59<br>(142.0) | 5.40<br>(137.2) | 5.42<br>(137.7) |

Assembly dimensions may exhibit expansion of 0.003" per station before installation, but will adjust to recommended panel dimensions shown once installed. Subtract 0.250" from each dimension shown for each S76SG spacer included in the assembly. Add 0.500" to each dimension per switch for assemblies over 10 stations. Tolerances .XXX ± 0.010", .XX ± 0.030. Metric equivalents shown in ( ).

**1976 MODEL**

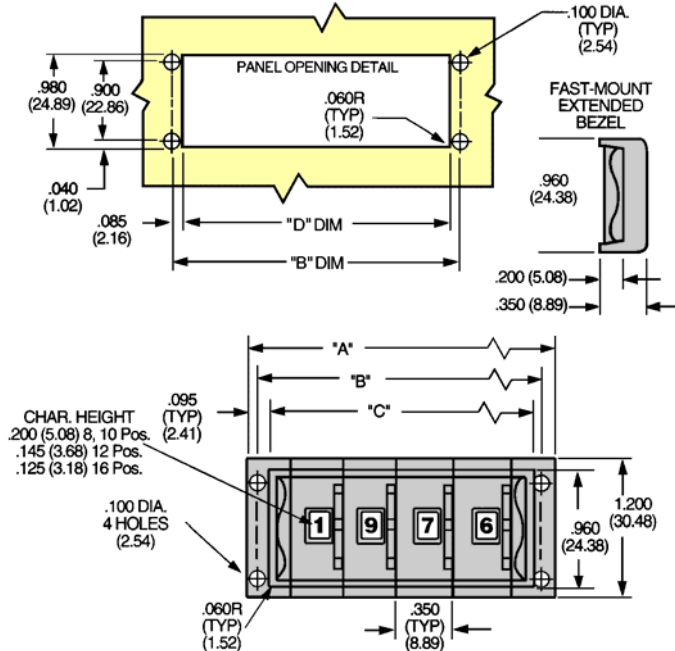

| NO. OF STATIONS | A               | B               | C              | D              |
|-----------------|-----------------|-----------------|----------------|----------------|
| 1               | 1.11<br>(28.2)  | 0.94<br>(23.9)  | 0.75<br>(19.1) | 0.77<br>(19.6) |
| 2               | 1.46<br>(37.1)  | 1.29<br>(32.8)  | 1.10<br>(27.9) | 1.12<br>(28.4) |
| 3               | 1.81<br>(46.0)  | 1.64<br>(41.7)  | 1.45<br>(36.8) | 1.47<br>(37.3) |
| 4               | 2.16<br>(54.9)  | 1.99<br>(50.5)  | 1.80<br>(45.7) | 1.82<br>(46.2) |
| 5               | 2.51<br>(63.8)  | 2.34<br>(59.4)  | 2.15<br>(54.6) | 2.17<br>(55.1) |
| 6               | 2.86<br>(72.6)  | 2.69<br>(68.3)  | 2.50<br>(63.5) | 2.52<br>(64.0) |
| 7               | 3.21<br>(81.5)  | 3.04<br>(77.2)  | 2.85<br>(72.4) | 2.87<br>(72.9) |
| 8               | 3.56<br>(90.4)  | 3.39<br>(86.1)  | 3.20<br>(81.3) | 3.22<br>(81.8) |
| 9               | 3.91<br>(99.3)  | 3.74<br>(95.0)  | 3.55<br>(90.2) | 3.57<br>(90.7) |
| 10              | 4.26<br>(108.2) | 4.09<br>(103.9) | 3.90<br>(99.1) | 3.92<br>(99.6) |

Assembly dimensions may exhibit expansion of 0.003" per station before installation, but will adjust to recommended panel dimensions shown once installed. Add 0.350" to each dimension per switch for assemblies over 10 stations. Tolerances .XXX ± 0.010", .XX ± 0.030. Metric equivalents shown in ( ).



## 1776/1976 Series

### STANDARD SWITCH MODELS

| TRUTH TABLE | 1776 SERIES | 1976 SERIES | PRODUCT DESCRIPTION                           | NO. Of POSITIONS |
|-------------|-------------|-------------|---|------------------|
| A02         | 177601G     | 197601G     | 1 Pole Decimal                                | 10               |
| A02         | 177641G     | 197641G     | 1 Pole Decimal Make-Before Break              | 10               |
| A08         | 177640G     | 197640G     | 2 Pole 5 Pos. Decimal Mkd. 0-4                | 5                |
| B01         | 177608G     | 197608G     | 1 Pole BCO                                    | 8                |
| B01         | 177658G†    | 197658G†    | 1 Pole BCO w/Diode Provision                  | 8                |
| B02         | 177602G     | 197602G     | 1 Pole BCD                                    | 10               |
| B02         | 177652G†    | 197652G†    | 1 Pole BCD Diode Provision                    | 10               |
| B04         | 177632G     | 197632G     | 1 Pole 12 Position Binary                     | 12               |
| B04         | 177682G†    | 197682G†    | 1 Pole 12 Binary w/Diode Provision            | 12               |
| B07         | 177633G     | 197633G     | 1 Pole BCH Marked 0-15                        | 16               |
| B07         | 177634G     | 197634G     | 1 Pole BCH Marked 0-9-A-F                     | 16               |
| C10         | 177603G     | 197603G     | 1 Pole Excess 3                               | 10               |
| C10         | 177653G†    | 197653G†    | 1 Pole Excess 3 w/Diode Provision             | 10               |
| C11         | 177618G     | 197618G     | 1 Pole BCO Complement                         | 8                |
| C11         | 177668G†    | 197668G†    | 1 Pole BCO Complement w/Diode Provision       | 8                |
| C12         | 177612G     | 197612G     | 1 Pole BCD Complement                         | 10               |
| C12         | 177662G†    | 197662G†    | 1 Pole BCD Complement w/Diode Provision       | 10               |
| C13         | 177619G     | 197619G     | 1 Pole 9's Complement                         | 10               |
| C13         | 177669G†    | 197669G†    | 1 Pole 9's Complement w/Diode Provision       | 10               |
| C14         | 177621G     | 197621G     | 1 Pole 10's Complement                        | 10               |
| C14         | 177671G†    | 197671G†    | 1 Pole 10's Complement w/Diode Provision      | 10               |
| C15         | 177617G     | 197617G     | 1 Pole Complement of 9's Complement           | 10               |
| C15         | 177667G†    | 197667G†    | 1 Pole Complement of 9's Compl. w/Diode Prov. | 10               |
| D02         | 177656G     | 197656G     | 2 Pole BCD w/Separate Common to Not True Bits | 10               |
| D03         | 177626G     | 197626G     | 2 Pole Dual BCD                               | 10               |
| D04         | 177637G     | 197637G     | 2 Pole BCH Marked 0-15w/Complement            | 16               |
| D04         | 177638G     | 197638G     | 2 Pole BCH Marked 0-9-A-F w/Complement        | 16               |
| E01         | 177609G     | 197609G     | 1 Pole BCO w/Complement                       | 8                |
| E02         | 177606G     | 197606G     | 2 Pole BCD w/Complement                       | 10               |
| E04         | 177620G     | 197620G     | 2 Pole 9's Complement w/Complement            | 10               |
| E05         | 177622G     | 197622G     | 2 Pole 10's Complement w/Complement           | 10               |
| E05         | 177623G     | 197623G     | 1 Pole Complement of 10's Complement          | 10               |
| E06         | 177636G     | 197636G     | 2 Pole 12 Pos. Binary w/Complement            | 12               |
| E07         | 177614G     | 197614G     | 2 Pole Excess 3 w/Complement                  | 10               |
| E08         | 177646G     | 197646G     | 4 Pole Special BCD w/Complement               | 10               |
| G02         | 177615G     | 197615G     | 1 Pole 1-2-4-2' Code                          | 10               |
| N/A         | 177691G     | 197691G     | Non Functional Switch                         | 10               |
| S01         | 177605G     | 197605G     | 2 Pole Repeating Marked 0-5                   | 10               |
| S01         | 177610G     | 197610G     | 2 Pole Repeating Marked 0-1                   | 10               |
| S01         | 177611G     | 197611G     | 2 Pole Repeating Marked +/-                   | 10               |
| S08         | 177616G     | 197616G     | Wolff-Poggendorf Voltage Divider              | 10               |
| S10         | 177604G     | 197604G     | Resistor Decade(1-2-3-6)                      | 10               |
| S11         | 177607G     | 197607G     | 7 Bar Indicator                               | 10               |
| S15         | 177642G     | 197642G     | 1 Pole Mod. Teletype Code                     | 10               |
| S17         | 177624G     | 197624G     | Resistor Decade 1-2-4-2' Code                 | 10               |
| S18         | 177625G     | 197625G     | Resistor Decade 1-2-2-2-2 Code                | 10               |
| S20         | 177645G     | 197645G     | 2 Pole 1-1'-2-5 w/Complement                  | 10               |
| S21         | 177676GN    | 197676GN    | Thumbpot Voltage Divider                      | 10               |
| S22         | 177627G     | 197627G     | 1 Pole 1-2-4-5 Code                           | 10               |
| S23         | 177674G     | 197674G     | 1 Pole Johnson Code                           | 10               |

NOTE: † Includes row of inactive terminals for mounting components. Consult factory for additional information.



AVAILABLE OPTIONS

- A Diodes Installed Anode To Common
  - C Diodes Installed Cathode To Common
  - D Decimal Point
  - G Gloss Finish (Standard)
  - K Lighted Decimal Point
  - L Lighted Switch Legend, black hot-stamped character on white translucent background. 5 Volt lamp standard, consult factory for other voltages
  - M Spray Matte Finish
  - N Notched Terminals – Required to attach PC boards. Also accepts soldered cable connection
  - P +/-Rotor Marking
  - R Reverse Lighting – Illuminated white character on black background
  - T Alphabet Marking
  - U EMI/RFI Shielding
  - Y Fast Mount Hardware (applies to assembly part number)
- Stop Pins  
 Consult Factory for Custom Rotor Marking, Double-Wide Switch Modules, Custom Output Codes and Other Special Requests

ORDERING EXAMPLE - SWITCH

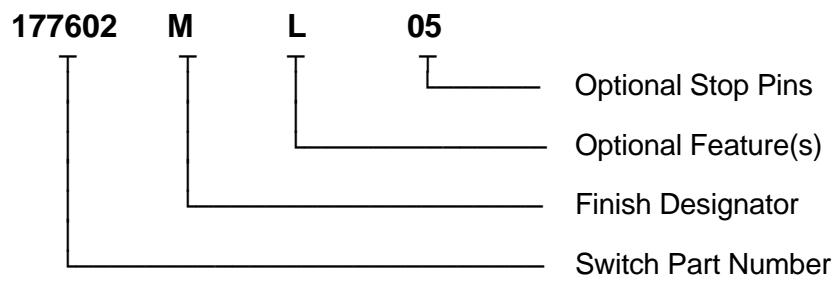

ORDERING EXAMPLE - SWITCH ASSEMBLY

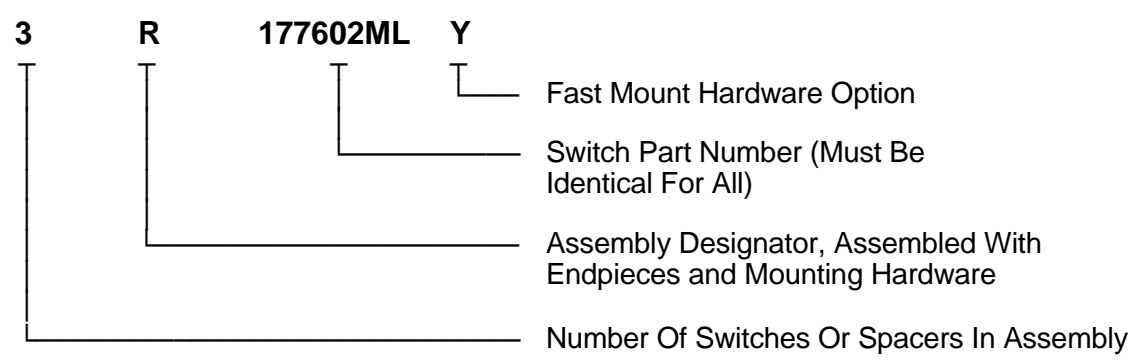

Assemblies of mixed switches and/or certain options require a special assembly number. Consult factory for additional ordering information.



# EECO SWITCH STANDARD TRUTH TABLES

EECO Switch offers over 60 binary, decimal, and special purpose electrical output codes. The code designations (e.g. B02) are common to all EECO Switch products. Not all codes are offered in every switch series.

Using the truth tables on the following pages, select the electrical code that suits your circuit. Then select the corresponding 1776/1976 Series part number from the table on page 4. The most common output codes are highlighted in *red*

Contact the factory for additional information and availability of other codes and options.

## SINGLE POLE DECIMAL CODES

A01

| OCTAL       |   | 1 Pole 8 Position |   |   |   |   |   |   |
|-------------|---|-------------------|---|---|---|---|---|---|
| D<br>I<br>A | Common (C) connected to terminals indicated |                   |   |   |   |   |   |   |
|             | L   | 0                 | 1 | 2 | 3 | 4 | 5 | 6 |
| 0           | ●   |                   |   |   |   |   |   |   |
| 1           |   | ●                 |   |   |   |   |   |   |
| 2           |   |                   | ● |   |   |   |   |   |
| 3           |   |                   |   | ● |   |   |   |   |
| 4           |   |                   |   |   | ● |   |   |   |
| 5           |   |                   |   |   |   | ● |   |   |
| 6           |   |                   |   |   |   |   | ● |   |
| 7           |   |                   |   |   |   |   |   | ● |

A02

| DECIMAL     |   | 1 Pole 10 Position |   |   |   |   |   |   |   |   |   |
|-------------|---|--------------------|---|---|---|---|---|---|---|---|---|
| D<br>I<br>A | Common (C) connected to terminals indicated |                    |   |   |   |   |   |   |   |   |   |
|             | L   | 0                  | 1 | 2 | 3 | 4 | 5 | 6 | 7 | 8 | 9 |
| 0           | ●   |                    |   |   |   |   |   |   |   |   |   |
| 1           |   | ●                  |   |   |   |   |   |   |   |   |   |
| 2           |   |                    | ● |   |   |   |   |   |   |   |   |
| 3           |   |                    |   | ● |   |   |   |   |   |   |   |
| 4           |   |                    |   |   | ● |   |   |   |   |   |   |
| 5           |   |                    |   |   |   | ● |   |   |   |   |   |
| 6           |   |                    |   |   |   |   | ● |   |   |   |   |
| 7           |   |                    |   |   |   |   |   | ● |   |   |   |
| 8           |   |                    |   |   |   |   |   |   | ● |   |   |
| 9           |   |                    |   |   |   |   |   |   |   | ● |   |

A03

|             |   | 1 Pole 12 Position |   |   |   |   |   |   |   |   |   |    |    |
|-------------|---|--------------------|---|---|---|---|---|---|---|---|---|----|----|
| D<br>I<br>A | Common (C) connected to terminals indicated |                    |   |   |   |   |   |   |   |   |   |    |    |
|             | L   | 0                  | 1 | 2 | 3 | 4 | 5 | 6 | 7 | 8 | 9 | 10 | 11 |
| 0           | ●   |                    |   |   |   |   |   |   |   |   |   |    |    |
| 1           |   | ●                  |   |   |   |   |   |   |   |   |   |    |    |
| 2           |   |                    | ● |   |   |   |   |   |   |   |   |    |    |
| 3           |   |                    |   | ● |   |   |   |   |   |   |   |    |    |
| 4           |   |                    |   |   | ● |   |   |   |   |   |   |    |    |
| 5           |   |                    |   |   |   | ● |   |   |   |   |   |    |    |
| 6           |   |                    |   |   |   |   | ● |   |   |   |   |    |    |
| 7           |   |                    |   |   |   |   |   | ● |   |   |   |    |    |
| 8           |   |                    |   |   |   |   |   |   | ● |   |   |    |    |
| 9           |   |                    |   |   |   |   |   |   |   | ● |   |    |    |
| 10          |   |                    |   |   |   |   |   |   |   |   | ● |    |    |
| 11          |   |                    |   |   |   |   |   |   |   |   |   | ●  |    |

A04

|             |   | 1 Pole 16 Position |   |   |   |   |   |   |   |   |   |    |    |    |    |    |    |
|-------------|---|--------------------|---|---|---|---|---|---|---|---|---|----|----|----|----|----|----|
| D<br>I<br>A | Common (C) connected to terminals indicated |                    |   |   |   |   |   |   |   |   |   |    |    |    |    |    |    |
|             | L   | 0                  | 1 | 2 | 3 | 4 | 5 | 6 | 7 | 8 | 9 | 10 | 11 | 12 | 13 | 14 | 15 |
| 0           | ●   |                    |   |   |   |   |   |   |   |   |   |    |    |    |    |    |    |
| 1           |   | ●                  |   |   |   |   |   |   |   |   |   |    |    |    |    |    |    |
| 2           |   |                    | ● |   |   |   |   |   |   |   |   |    |    |    |    |    |    |
| 3           |   |                    |   | ● |   |   |   |   |   |   |   |    |    |    |    |    |    |
| 4           |   |                    |   |   | ● |   |   |   |   |   |   |    |    |    |    |    |    |
| 5           |   |                    |   |   |   | ● |   |   |   |   |   |    |    |    |    |    |    |
| 6           |   |                    |   |   |   |   | ● |   |   |   |   |    |    |    |    |    |    |
| 7           |   |                    |   |   |   |   |   | ● |   |   |   |    |    |    |    |    |    |
| 8           |   |                    |   |   |   |   |   |   | ● |   |   |    |    |    |    |    |    |
| 9           |   |                    |   |   |   |   |   |   |   | ● |   |    |    |    |    |    |    |
| 10          |   |                    |   |   |   |   |   |   |   |   | ● |    |    |    |    |    |    |
| 11          |   |                    |   |   |   |   |   |   |   |   |   | ●  |    |    |    |    |    |
| 12          |   |                    |   |   |   |   |   |   |   |   |   |    | ●  |    |    |    |    |
| 13          |   |                    |   |   |   |   |   |   |   |   |   |    |    | ●  |    |    |    |
| 14          |   |                    |   |   |   |   |   |   |   |   |   |    |    |    | ●  |    |    |
| 15          |   |                    |   |   |   |   |   |   |   |   |   |    |    |    |    | ●  |    |

## DOUBLE POLE DECIMAL CODES

A05

| DECIMAL     |   | 2 Pole 10 Position |   |   |   |  |   |   |   |   |   |    |    |    |    |    |    |    |    |    |    |  |
|-------------|---|--------------------|---|---|---|--|---|---|---|---|---|----|----|----|----|----|----|----|----|----|----|--|
| D<br>I<br>A | Common (C) connected to terminals indicated |                    |   |   |   | Common (C') connected to terminals indicated |   |   |   |   |   |    |    |    |    |    |    |    |    |    |    |  |
|             | L   | 0                  | 1 | 2 | 3 | 4  | 5 | 6 | 7 | 8 | 9 | 0' | 1' | 2' | 3' | 4' | 5' | 6' | 7' | 8' | 9' |  |
| 0           | ●   |                    |   |   |   |  |   |   |   |   |   | ●  |    |    |    |    |    |    |    |    |    |  |
| 1           |   | ●                  |   |   |   |  |   |   |   |   |   |    | ●  |    |    |    |    |    |    |    |    |  |
| 2           |   |                    | ● |   |   |  |   |   |   |   |   |    |    | ●  |    |    |    |    |    |    |    |  |
| 3           |   |                    |   | ● |   |  |   |   |   |   |   |    |    |    | ●  |    |    |    |    |    |    |  |
| 4           |   |                    |   |   | ● |  |   |   |   |   |   |    |    |    |    | ●  |    |    |    |    |    |  |
| 5           |   |                    |   |   |   | ●  |   |   |   |   |   |    |    |    |    |    | ●  |    |    |    |    |  |
| 6           |   |                    |   |   |   |  | ● |   |   |   |   |    |    |    |    |    |    | ●  |    |    |    |  |
| 7           |   |                    |   |   |   |  |   | ● |   |   |   |    |    |    |    |    |    |    | ●  |    |    |  |
| 8           |   |                    |   |   |   |  |   |   | ● |   |   |    |    |    |    |    |    |    |    | ●  |    |  |
| 9           |   |                    |   |   |   |  |   |   |   | ● |   |    |    |    |    |    |    |    |    |    | ●  |  |

A06

| DECIMAL     |   | 2 Pole 10 Position |   |   |   |  |   |   |   |   |   |    |    |    |    |    |    |    |    |    |    |  |
|-------------|---|--------------------|---|---|---|--|---|---|---|---|---|----|----|----|----|----|----|----|----|----|----|--|
| D<br>I<br>A | Common (C) connected to terminals indicated |                    |   |   |   | Common (C') connected to terminals indicated |   |   |   |   |   |    |    |    |    |    |    |    |    |    |    |  |
|             | L   | 0                  | 1 | 2 | 3 | 4  | 5 | 6 | 7 | 8 | 9 | 0' | 1' | 2' | 3' | 4' | 5' | 6' | 7' | 8' | 9' |  |
| 0           | ●   |                    |   |   |   |  |   |   |   |   |   | ●  |    |    |    |    |    |    |    |    |    |  |
| 1           |   | ●                  |   |   |   |  |   |   |   |   |   |    | ●  |    |    |    |    |    |    |    |    |  |
| 2           |   |                    | ● |   |   |  |   |   |   |   |   |    |    | ●  |    |    |    |    |    |    |    |  |
| 3           |   |                    |   | ● |   |  |   |   |   |   |   |    |    |    | ●  |    |    |    |    |    |    |  |
| 4           |   |                    |   |   | ● |  |   |   |   |   |   |    |    |    |    | ●  |    |    |    |    |    |  |
| 5           |   |                    |   |   |   | ●  |   |   |   |   |   |    |    |    |    |    | ●  |    |    |    |    |  |
| 6           |   |                    |   |   |   |  | ● |   |   |   |   |    |    |    |    |    |    | ●  |    |    |    |  |
| 7           |   |                    |   |   |   |  |   | ● |   |   |   |    |    |    |    |    |    |    | ●  |    |    |  |
| 8           |   |                    |   |   |   |  |   |   | ● |   |   |    |    |    |    |    |    |    |    | ●  |    |  |
| 9           |   |                    |   |   |   |  |   |   |   | ● |   |    |    |    |    |    |    |    |    |    | ●  |  |

A07

| DECIMAL     |   | 1 Pole 12 Position |   |   |   |   |  |   |   |   |   |    |    |    |    |    |    |    |    |    |    |    |    |     |     |
|-------------|---|--------------------|---|---|---|---|--|---|---|---|---|----|----|----|----|----|----|----|----|----|----|----|----|-----|-----|
| D<br>I<br>A | Common (C) connected to terminals indicated |                    |   |   |   |   | Common (C') connected to terminals indicated |   |   |   |   |    |    |    |    |    |    |    |    |    |    |    |    |     |     |
|             | L   | 0                  | 1 | 2 | 3 | 4 | 5  | 6 | 7 | 8 | 9 | 10 | 11 | 0' | 1' | 2' | 3' | 4' | 5' | 6' | 7' | 8' | 9' | 10' | 11' |
| 0           | ●   |                    |   |   |   |   |  |   |   |   |   |    |    | ●  |    |    |    |    |    |    |    |    |    |     |     |
| 1           |   | ●                  |   |   |   |   |  |   |   |   |   |    |    |    | ●  |    |    |    |    |    |    |    |    |     |     |
| 2           |   |                    | ● |   |   |   |  |   |   |   |   |    |    |    |    | ●  |    |    |    |    |    |    |    |     |     |
| 3           |   |                    |   | ● |   |   |  |   |   |   |   |    |    |    |    |    | ●  |    |    |    |    |    |    |     |     |
| 4           |   |                    |   |   | ● |   |  |   |   |   |   |    |    |    |    |    |    | ●  |    |    |    |    |    |     |     |
| 5           |   |                    |   |   |   | ● |  |   |   |   |   |    |    |    |    |    |    |    | ●  |    |    |    |    |     |     |
| 6           |   |                    |   |   |   |   | ●  |   |   |   |   |    |    |    |    |    |    |    |    | ●  |    |    |    |     |     |
| 7           |   |                    |   |   |   |   |  | ● |   |   |   |    |    |    |    |    |    |    |    |    | ●  |    |    |     |     |
| 8           |   |                    |   |   |   |   |  |   | ● |   |   |    |    |    |    |    |    |    |    |    |    | ●  |    |     |     |
| 9           |   |                    |   |   |   |   |  |   |   | ● |   |    |    |    |    |    |    |    |    |    |    |    | ●  |     |     |
| 10          |   |                    |   |   |   |   |  |   |   |   | ● |    |    |    |    |    |    |    |    |    |    |    | ●  |     |     |
| 11          |   |                    |   |   |   |   |  |   |   |   |   | ●  |    |    |    |    |    |    |    |    |    |    |    | ●   |     |

A08

|             |  | 2 Pole 5 Position |   |   |   |   |    |    |    |    |    |
|-------------|--|-------------------|---|---|---|---|----|----|----|----|----|
| D<br>I<br>A | Common (C) and (C') connected to terminals indicated |                   |   |   |   |   |    |    |    |    |    |
|             | L  | 0                 | 1 | 2 | 3 | 4 | 0' | 1' | 2' | 3' | 4' |
| 0           | ●  |                   |   |   |   |   | ●  |    |    |    |    |
| 1           |  | ●                 |   |   |   |   |    | ●  |    |    |    |
| 2           |  |                   | ● |   |   |   |    |    | ●  |    |    |
| 3           |  |                   |   | ● |   |   |    |    |    | ●  |    |
| 4           |  |                   |   |   | ● |   |    |    |    |    | ●  |



| B01                      |   | B02                       |   | B03                                       |   | B04                               |   | B05  |   | B06   |   |
|--------------------------|---|---------------------------|---|---|---|-----------------------------------|---|--|---|---|---|
| BCD<br>1 Pole 8 Position |   | BCD<br>1 Pole 10 Position |   | BCD, binary 10 at 0<br>1 Pole 10 Position |   | BINARY CODE<br>1 Pole 12 Position |   | BCD, with Odd Bit Parity<br>1 Pole 10 Position |   | BCD, with Even Bit Parity<br>1 Pole 10 Position |   |
| D                        | Common (C) connected to terminals indicated | D                         | Common (C) connected to terminals indicated | D   | Common (C) connected to terminals indicated | D                                 | Common (C) connected to terminals indicated | D  | Common (C) connected to terminals indicated | D   | Common (C) connected to terminals indicated |
| I                        |   | I                         |   | I   |   | I                                 |   | I  |   | I   |   |
| A                        |   | A                         |   | A   |   | A                                 |   | A  |   | A   |   |
| L                        | 1 2 4                                       | L                         | 1 2 4 8                                     | L   | 1 2 4 8                                     | L                                 | 1 2 4 8                                     | L  | 1 2 4 8 P                                   | L   | 1 2 4 8 P                                   |
| 0                        |   | 0                         |   | 0   |   | 0                                 |   | 0  |   | 0   |   |
| 1                        | ●   | 1                         | ●   | 1   | ●   | 1                                 | ●   | 1  | ●   | 1   | ●   |
| 2                        | ●   | 2                         | ●   | 2   | ●   | 2                                 | ●   | 2  | ●   | 2   | ●   |
| 3                        | ●   | 3                         | ●   | 3   | ●   | 3                                 | ●   | 3  | ●   | 3   | ●   |
| 4                        | ●   | 4                         | ●   | 4   | ●   | 4                                 | ●   | 4  | ●   | 4   | ●   |
| 5                        | ●   | 5                         | ●   | 5   | ●   | 5                                 | ●   | 5  | ●   | 5   | ●   |
| 6                        | ●   | 6                         | ●   | 6   | ●   | 6                                 | ●   | 6  | ●   | 6   | ●   |
| 7                        | ●   | 7                         | ●   | 7   | ●   | 7                                 | ●   | 7  | ●   | 7   | ●   |
| 8                        | ●   | 8                         | ●   | 8   | ●   | 8                                 | ●   | 8  | ●   | 8   | ●   |
| 9                        | ●   | 9                         | ●   | 9   | ●   | 9                                 | ●   | 9  | ●   | 9   | ●   |
| 10                       |   |                           |   |   |   | 10                                | ●   |  |   |   |   |
| 11                       |   |                           |   |   |   | 11                                | ●   |  |   |   |   |

| B07                               |   | C02                                    |   | C03  |   | C04  |   | C06   |   |
|-----------------------------------|---|--|---|--|---|--|---|---|---|
| Binary Code<br>1-Pole 16-Position |   | BCD w/Complement<br>1 Pole 10 Position |   | BCD w/Complement<br>Binary 10 at 0<br>1 Pole 10 Position |   | Binary Code w/Complement<br>1 Pole 12 Position |   | Binary Code W/Complement<br>1-Pole, 16-Position |   |
| D                                 | Common (C) connected to terminals indicated | D                                      | Common (C) connected to terminals indicated | D  | Common (C) connected to terminals indicated | D  | Common (C) connected to terminals indicated | D   | Common (C) connected to terminals indicated |
| I                                 |   | I                                      |   | I  |   | I  |   | I   |   |
| A                                 |   | A                                      |   | A  |   | A  |   | A   |   |
| L                                 | 1 2 4 8                                     | L                                      | 1 2 4 8 1 2 4 8                             | L  | 1 2 4 8 T 2 4 8                             | L  | 1 2 4 8 T 2 4 8                             | L   | 1 2 4 8 T 2 4 8                             |
| 0                                 | 0   | 0                                      | ●   | 0  | ●   | 0  | ●   | 0   | ●   |
| 1                                 | 1   | 1                                      | ●   | 1  | ●   | 1  | ●   | 1   | ●   |
| 2                                 | 2   | 2                                      | ●   | 2  | ●   | 2  | ●   | 2   | ●   |
| 3                                 | 3   | 3                                      | ●   | 3  | ●   | 3  | ●   | 3   | ●   |
| 4                                 | 4   | 4                                      | ●   | 4  | ●   | 4  | ●   | 4   | ●   |
| 5                                 | 5   | 5                                      | ●   | 5  | ●   | 5  | ●   | 5   | ●   |
| 6                                 | 6   | 6                                      | ●   | 6  | ●   | 6  | ●   | 6   | ●   |
| 7                                 | 7   | 7                                      | ●   | 7  | ●   | 7  | ●   | 7   | ●   |
| 8                                 | 8   | 8                                      | ●   | 8  | ●   | 8  | ●   | 8   | ●   |
| 9                                 | 9   | 9                                      | ●   | 9  | ●   | 9  | ●   | 9   | ●   |
| A                                 | 10  |  |   |  |   | 10   | ●   | 10  | ●   |
| B                                 | 11  |  |   |  |   | 11   | ●   | 11  | ●   |
| C                                 | 12  |  |   |  |   | 12   | ●   | 12  | ●   |
| D                                 | 13  |  |   |  |   | 13   | ●   | 13  | ●   |
| E                                 | 14  |  |   |  |   | 14   | ●   | 14  | ●   |
| F                                 | 15  |  |   |  |   | 15   | ●   | 15  | ●   |

| C07  |   | C08   |   | C09  |   | C10                                |   |
|--|---|---|---|--|---|------------------------------------|---|
| BCD Excess 3, w/Complement<br>1 Pole 10 Position |   | 9's Complement BCD,<br>w/Complement<br>1 Pole 10 Position |   | 10's Complement BCD,<br>w/Complement<br>1 Pole 10 Position |   | BCD Excess 3<br>1 Pole 10 Position |   |
| D  | Common (C) connected to terminals indicated | D   | Common (C) connected to terminals indicated | D  | Common (C) connected to terminals indicated | D                                  | Common (C) connected to terminals indicated |
| I  |   | I   |   | I  |   | I                                  |   |
| A  |   | A   |   | A  |   | A                                  |   |
| L  | 1 2 4 8 1 2 4 8                             | L   | 1 2 4 8 T 2 4 8                             | L  | 1 2 4 8 T 2 4 8                             | L                                  | 1 2 4 8                                     |
| 0  | ●   | 0   | ●   | 0  | ●   | 0                                  | ●   |
| 1  | ●   | 1   | ●   | 1  | ●   | 1                                  | ●   |
| 2  | ●   | 2   | ●   | 2  | ●   | 2                                  | ●   |
| 3  | ●   | 3   | ●   | 3  | ●   | 3                                  | ●   |
| 4  | ●   | 4   | ●   | 4  | ●   | 4                                  | ●   |
| 5  | ●   | 5   | ●   | 5  | ●   | 5                                  | ●   |
| 6  | ●   | 6   | ●   | 6  | ●   | 6                                  | ●   |
| 7  | ●   | 7   | ●   | 7  | ●   | 7                                  | ●   |
| 8  | ●   | 8   | ●   | 8  | ●   | 8                                  | ●   |
| 9  | ●   | 9   | ●   | 9  | ●   | 9                                  | ●   |

| C11                                      |   | C12                                       |   | C13                                      |   | C14                                       |   | C15                                  |   |
|--|---|---|---|--|---|---|---|--------------------------------------|---|
| BCD Complement Only<br>1 Pole 8 Position |   | BCD Complement Only<br>1 Pole 10 Position |   | 9's Complement BCD<br>1 Pole 10 Position |   | 10's Complement BCD<br>1 Pole 10 Position |   | 9's Complement<br>1 Pole 10 Position |   |
| D  | Common (C) connected to terminals indicated | D   | Common (C) connected to terminals indicated | D  | Common (C) connected to terminals indicated | D   | Common (C) connected to terminals indicated | D                                    | Common (C) connected to terminals indicated |
| I  |   | I   |   | I  |   | I   |   | I                                    |   |
| A  |   | A   |   | A  |   | A   |   | A                                    |   |
| L  | 1 2 4                                       | L   | 1 2 4 8                                     | L  | 1 2 4 8                                     | L   | 1 2 4 8                                     | L                                    | 1 2 4 8                                     |
| 0  | ●   | 0   | ●   | 0  | ●   | 0   | ●   | 0                                    | ●   |
| 1  | ●   | 1   | ●   | 1  | ●   | 1   | ●   | 1                                    | ●   |
| 2  | ●   | 2   | ●   | 2  | ●   | 2   | ●   | 2                                    | ●   |
| 3  | ●   | 3   | ●   | 3  | ●   | 3   | ●   | 3                                    | ●   |
| 4  | ●   | 4   | ●   | 4  | ●   | 4   | ●   | 4                                    | ●   |
| 5  | ●   | 5   | ●   | 5  | ●   | 5   | ●   | 5                                    | ●   |
| 6  | ●   | 6   | ●   | 6  | ●   | 6   | ●   | 6                                    | ●   |
| 7  | ●   | 7   | ●   | 7  | ●   | 7   | ●   | 7                                    | ●   |
| 8  | ●   | 8   | ●   | 8  | ●   | 8   | ●   | 8                                    | ●   |
| 9  | ●   | 9   | ●   | 9  | ●   | 9   | ●   | 9                                    | ●   |

| C16  |   |
|--|---|
| Binary Complement only<br>1-Pole 16-Position |   |
| D  | Common (C) connected to terminals indicated |
| I  |   |
| A  |   |
| L  | 1 2 4 8                                     |
| 0  | ●   |
| 1  | ●   |
| 2  | ●   |
| 3  | ●   |
| 4  | ●   |
| 5  | ●   |
| 6  | ●   |
| 7  | ●   |
| 8  | ●   |
| 9  | ●   |
| A  | 10  |
| B  | 11  |
| C  | 12  |
| D  | 13  |
| E  | 14  |
| F  | 15  |



D01

BCD 2 Pole 8 Position w/Sep Com to NT Bits

|   |   |   |   |  |           |   |   |   |
|---|---|---|---|--|-----------|---|---|---|
| D | Common C (●) and C (★) connected to terminals indicated |   |   |  |           |   |   |   |
| I |   |   |   |  |           |   |   |   |
| A |   |   |   |  |           |   |   |   |
| L | C   |   |   |  | $\bar{C}$ |   |   |   |
|   | 1   | 2 | 4 |  | 1         | 2 | 4 | 8 |
| 0 | ★   | ★ | ★ |  |           |   |   |   |
| 1 | ●   | ★ | ★ |  |           |   |   |   |
| 2 | ★   | ● | ★ |  |           |   |   |   |
| 3 | ●   | ● | ★ |  |           |   |   |   |
| 4 | ★   | ★ | ● |  |           |   |   |   |
| 5 | ●   | ★ | ● |  |           |   |   |   |
| 6 | ★   | ● | ● |  |           |   |   |   |
| 7 | ●   | ● | ● |  |           |   |   |   |

D02

BCD 2 Pole 10 Position Sep Com to NT Bits

|   |   |   |   |   |  |    |   |   |   |  |
|---|---|---|---|---|--|----|---|---|---|--|
| D | Common C (●) and C (★) connected to terminals indicated |   |   |   |  |    |   |   |   |  |
| I |   |   |   |   |  |    |   |   |   |  |
| A |   |   |   |   |  |    |   |   |   |  |
| L | C1  |   |   |   |  | C2 |   |   |   |  |
|   | 1   | 2 | 4 | 8 |  | 1  | 2 | 4 | 8 |  |
| 0 | ★   | ★ | ★ | ★ |  |    |   |   |   |  |
| 1 | ●   | ★ | ★ | ★ |  |    |   |   |   |  |
| 2 | ★   | ● | ★ | ★ |  |    |   |   |   |  |
| 3 | ●   | ● | ★ | ★ |  |    |   |   |   |  |
| 4 | ★   | ★ | ● | ★ |  |    |   |   |   |  |
| 5 | ●   | ★ | ● | ★ |  |    |   |   |   |  |
| 6 | ★   | ● | ● | ★ |  |    |   |   |   |  |
| 7 | ●   | ★ | ● | ★ |  |    |   |   |   |  |
| 8 | ★   | ★ | ★ | ★ |  |    |   |   |   |  |
| 9 | ●   | ● | ● | ● |  |    |   |   |   |  |

D03

BCD Dual, 2 Pole 10 Position

|   |   |   |   |   |   |    |   |   |   |   |
|---|---|---|---|---|---|----|---|---|---|---|
| D | Common (C1) and (C2) connected to terminals indicated |   |   |   |   |    |   |   |   |   |
| I |   |   |   |   |   |    |   |   |   |   |
| A |   |   |   |   |   |    |   |   |   |   |
| L | C1  |   |   |   |   | C2 |   |   |   |   |
|   | 1   | 2 | 4 | 8 |   | 1  | 2 | 4 | 8 |   |
| 0 |   |   |   |   |   |    |   |   |   |   |
| 1 | ●   |   |   |   |   | ●  |   |   |   |   |
| 2 |   | ● |   |   |   |    | ● |   |   |   |
| 3 |   |   | ● |   |   |    |   | ● |   |   |
| 4 |   |   |   | ● |   |    |   |   | ● |   |
| 5 | ●   |   |   |   | ● |    |   |   |   | ● |
| 6 |   | ● |   |   |   | ●  |   |   |   |   |
| 7 |   |   | ● |   |   |    | ● |   |   |   |
| 8 |   |   |   | ● |   |    |   | ● |   |   |
| 9 | ●   |   |   |   | ● |    |   |   |   | ● |

D04

Binary Code w/Complement 2 Pole 16 Position

|   |   |   |   |   |   |   |   |   |           |   |   |   |   |   |   |   |
|---|---|---|---|---|---|---|---|---|-----------|---|---|---|---|---|---|---|
| D | Common (C) and (C) connected to terminals indicated |   |   |   |   |   |   |   |           |   |   |   |   |   |   |   |
| I |   |   |   |   |   |   |   |   |           |   |   |   |   |   |   |   |
| A |   |   |   |   |   |   |   |   |           |   |   |   |   |   |   |   |
| L | C   |   |   |   |   |   |   |   | $\bar{C}$ |   |   |   |   |   |   |   |
|   | 1   | 2 | 4 | 8 | 1 | 2 | 4 | 8 | 1         | 2 | 4 | 8 | 1 | 2 | 4 | 8 |
| 0 | 0   |   |   |   |   |   |   |   | ●         | ● | ● | ● |   |   |   |   |
| 1 | 1   | ● |   |   |   |   |   |   |           |   |   |   | ● | ● | ● | ● |
| 2 | 2   |   | ● |   |   |   |   |   |           |   |   |   |   | ● | ● | ● |
| 3 | 3   |   |   | ● |   |   |   |   |           |   |   |   |   |   | ● | ● |
| 4 | 4   |   |   |   | ● |   |   |   |           |   |   |   |   |   |   | ● |
| 5 | 5   | ● |   |   |   | ● |   |   |           |   |   |   |   |   |   | ● |
| 6 | 6   |   | ● |   |   |   | ● |   |           |   |   |   |   |   |   | ● |
| 7 | 7   |   |   | ● |   |   |   | ● |           |   |   |   |   |   |   | ● |
| 8 | 8   |   |   |   | ● |   |   |   | ●         |   |   |   |   |   |   | ● |
| 9 | 9   | ● |   |   |   | ● |   |   |           |   |   |   |   |   |   | ● |
| A | 10  |   | ● |   |   |   | ● |   |           |   |   |   |   |   |   | ● |
| B | 11  |   |   | ● |   |   |   | ● |           |   |   |   |   |   |   | ● |
| C | 12  |   |   |   | ● |   |   |   | ●         |   |   |   |   |   |   | ● |
| D | 13  |   |   |   |   | ● |   |   |           | ● |   |   |   |   |   | ● |
| E | 14  |   |   |   |   |   | ● |   |           |   | ● |   |   |   |   | ● |
| F | 15  | ● |   |   |   |   |   | ● |           |   |   |   |   |   |   | ● |

D06

2 Pole Binary with Sep Com to NT Bits

|   |   |   |   |   |           |   |   |   |
|---|---|---|---|---|-----------|---|---|---|
| D | Common C (●) and C (★) connected to terminals indicated |   |   |   |           |   |   |   |
| I |   |   |   |   |           |   |   |   |
| A |   |   |   |   |           |   |   |   |
| L | C   |   |   |   | $\bar{C}$ |   |   |   |
|   | 1   | 2 | 4 | 8 | 1         | 2 | 4 | 8 |
| 0 | 0   | ★ | ★ | ★ | ★         |   |   |   |
| 1 | 1   | ● | ★ | ★ | ★         |   |   |   |
| 2 | 2   | ★ | ● | ★ | ★         |   |   |   |
| 3 | 3   | ● | ● | ★ | ★         |   |   |   |
| 4 | 4   | ★ | ★ | ● | ★         |   |   |   |
| 5 | 5   | ● | ★ | ● | ★         |   |   |   |
| 6 | 6   | ★ | ● | ● | ★         |   |   |   |
| 7 | 7   | ● | ● | ● | ★         |   |   |   |
| 8 | 8   | ★ | ★ | ★ | ★         |   |   |   |
| 9 | 9   | ● | ★ | ★ | ●         |   |   |   |
| A | 10  | ★ | ★ | ★ | ●         |   |   |   |
| B | 11  | ● | ★ | ★ | ●         |   |   |   |
| C | 12  | ★ | ★ | ★ | ●         |   |   |   |
| D | 13  | ● | ★ | ★ | ●         |   |   |   |
| E | 14  | ★ | ★ | ★ | ●         |   |   |   |
| F | 15  | ● | ● | ● | ●         |   |   |   |

E01

BCD w/Complement 2 Pole 8 Position

|   |   |   |   |  |           |   |   |   |
|---|---|---|---|--|-----------|---|---|---|
| D | Common (C) and (C) connected to terminals indicated |   |   |  |           |   |   |   |
| I |   |   |   |  |           |   |   |   |
| A |   |   |   |  |           |   |   |   |
| L | C   |   |   |  | $\bar{C}$ |   |   |   |
|   | 1   | 2 | 4 |  | 1         | 2 | 4 | 8 |
| 0 |   |   |   |  | ●         | ● | ● |   |
| 1 | ●   |   |   |  |           |   |   | ● |
| 2 |   | ● |   |  |           |   |   | ● |
| 3 | ●   |   |   |  |           |   |   | ● |
| 4 |   |   | ● |  |           |   |   | ● |
| 5 | ●   |   |   |  |           |   |   | ● |
| 6 |   | ● |   |  |           |   |   | ● |
| 7 | ●   |   |   |  |           |   |   | ● |

E02

BCD w/Complement 2 Pole 10 Position

|   |   |   |   |   |   |           |   |   |   |   |
|---|---|---|---|---|---|-----------|---|---|---|---|
| D | Common (C) and (C) connected to terminals indicated |   |   |   |   |           |   |   |   |   |
| I |   |   |   |   |   |           |   |   |   |   |
| A |   |   |   |   |   |           |   |   |   |   |
| L | C   |   |   |   |   | $\bar{C}$ |   |   |   |   |
|   | 1   | 2 | 4 | 8 |   | 1         | 2 | 4 | 8 |   |
| 0 |   |   |   |   |   | ●         | ● | ● | ● |   |
| 1 | ●   |   |   |   |   |           |   |   |   | ● |
| 2 |   | ● |   |   |   |           |   |   |   | ● |
| 3 | ●   |   |   |   |   |           |   |   |   | ● |
| 4 |   |   | ● |   |   |           |   |   |   | ● |
| 5 | ●   |   |   |   |   |           |   |   |   | ● |
| 6 |   | ● |   |   |   |           |   |   |   | ● |
| 7 | ●   |   |   |   |   |           |   |   |   | ● |
| 8 |   |   |   | ● |   |           |   |   |   | ● |
| 9 | ●   |   |   |   | ● |           |   |   |   | ● |

E04

9's Complement BCD, w/Complement 2 Pole 10 Position

|   |   |   |   |   |   |           |   |   |   |   |
|---|---|---|---|---|---|-----------|---|---|---|---|
| D | Common (C) and (C) connected to terminals indicated |   |   |   |   |           |   |   |   |   |
| I |   |   |   |   |   |           |   |   |   |   |
| A |   |   |   |   |   |           |   |   |   |   |
| L | C   |   |   |   |   | $\bar{C}$ |   |   |   |   |
|   | 1   | 2 | 4 | 8 |   | 1         | 2 | 4 | 8 |   |
| 0 |   |   |   |   |   | ●         | ● | ● | ● |   |
| 1 |   |   |   |   |   | ●         | ● | ● | ● |   |
| 2 | ●   |   |   |   |   |           |   |   |   | ● |
| 3 | ●   |   |   |   |   |           |   |   |   | ● |
| 4 | ●   |   |   |   |   |           |   |   |   | ● |
| 5 |   | ● |   |   |   |           |   |   |   | ● |
| 6 | ●   |   |   |   |   |           |   |   |   | ● |
| 7 | ●   |   |   |   |   |           |   |   |   | ● |
| 8 |   |   |   | ● |   |           |   |   |   | ● |
| 9 |   |   |   |   | ● |           |   |   |   | ● |

E05

10's Complement BCD, w/Complement 2 Pole 10 Position

|   |   |   |   |   |   |           |   |   |   |   |
|---|---|---|---|---|---|-----------|---|---|---|---|
| D | Common (C) and (C) connected to terminals indicated |   |   |   |   |           |   |   |   |   |
| I |   |   |   |   |   |           |   |   |   |   |
| A |   |   |   |   |   |           |   |   |   |   |
| L | C   |   |   |   |   | $\bar{C}$ |   |   |   |   |
|   | 1   | 2 | 4 | 8 |   | 1         | 2 | 4 | 8 |   |
| 1 |   |   |   |   |   | ●         | ● | ● | ● |   |
| 2 |   |   |   |   |   | ●         | ● | ● | ● |   |
| 3 | ●   |   |   |   |   |           |   |   |   | ● |
| 4 | ●   |   |   |   |   |           |   |   |   | ● |
| 5 | ●   |   |   |   |   |           |   |   |   | ● |
| 6 |   | ● |   |   |   |           |   |   |   | ● |
| 7 | ●   |   |   |   |   |           |   |   |   | ● |
| 8 | ●   |   |   |   |   |           |   |   |   | ● |
| 9 |   |   |   | ● |   |           |   |   |   | ● |
| 0 |   |   |   |   | ● |           |   |   |   | ● |

E06

Binary Code w/Complement 2 Pole 12 Position

|    |   |   |   |   |   |   |           |   |   |   |   |  |
|----|---|---|---|---|---|---|-----------|---|---|---|---|--|
| D  | Common (C) and (C) connected to terminals indicated |   |   |   |   |   |           |   |   |   |   |  |
| I  |   |   |   |   |   |   |           |   |   |   |   |  |
| A  |   |   |   |   |   |   |           |   |   |   |   |  |
| L  | C   |   |   |   |   |   | $\bar{C}$ |   |   |   |   |  |
|    | 1   | 2 | 4 | 8 |   | 1 | 2         | 4 | 8 |   |   |  |
| 0  |   |   |   |   |   | ● | ●         | ● | ● |   |   |  |
| 1  | ●   |   |   |   |   |   |           |   |   | ● | ● |  |
| 2  |   | ● |   |   |   |   |           |   |   |   | ● |  |
| 3  | ●   |   |   |   |   |   |           |   |   |   | ● |  |
| 4  |   |   | ● |   |   |   |           |   |   |   | ● |  |
| 5  | ●   |   |   |   |   |   |           |   |   |   | ● |  |
| 6  |   | ● |   |   |   |   |           |   |   |   | ● |  |
| 7  | ●   |   |   |   |   |   |           |   |   |   | ● |  |
| 8  |   |   |   | ● |   |   |           |   |   |   | ● |  |
| 9  | ●   |   |   |   | ● |   |           |   |   |   | ● |  |
| 10 |   | ● |   |   |   |   |           |   |   |   | ● |  |
| 11 | ●   |   |   |   |   |   |           |   |   |   | ● |  |

E07

BCD Excess 3, w/Complement 2 Pole 10 Position

|   |   |   |   |   |   |           |   |   |   |   |
|---|---|---|---|---|---|-----------|---|---|---|---|
| D | Common (C) and (C) connected to terminals indicated |   |   |   |   |           |   |   |   |   |
| I |   |   |   |   |   |           |   |   |   |   |
| A |   |   |   |   |   |           |   |   |   |   |
| L | C   |   |   |   |   | $\bar{C}$ |   |   |   |   |
|   | 1   | 2 | 4 | 8 |   | 1         | 2 | 4 | 8 |   |
| 0 | ●   | ● |   |   |   |           |   |   |   | ● |
| 1 |   |   | ● |   |   |           |   |   |   | ● |
| 2 |   | ● |   |   |   |           |   |   |   | ● |
| 3 | ●   |   |   |   |   |           |   |   |   | ● |
| 4 | ●   |   |   |   |   |           |   |   |   | ● |
| 5 |   |   | ● |   |   |           |   |   |   | ● |
| 6 | ●   |   |   |   |   |           |   |   |   | ● |
| 7 |   |   |   | ● |   |           |   |   |   | ● |
| 8 | ●   |   |   |   |   |           |   |   |   | ● |
| 9 |   |   |   |   | ● |           |   |   |   | ● |

E08

Special 4 Pole, BCD w/Complement

|   |   |   |   |   |    |   |   |   |    |   |   |   |    |   |   |   |
|---|---|---|---|---|----|---|---|---|----|---|---|---|----|---|---|---|
| D | Common (C1), (C2), (C3) and (C4) connected to terminals indicated |   |   |   |    |   |   |   |    |   |   |   |    |   |   |   |
| I |   |   |   |   |    |   |   |   |    |   |   |   |    |   |   |   |
| A |   |   |   |   |    |   |   |   |    |   |   |   |    |   |   |   |
| L | C1  |   |   |   | C2 |   |   |   | C3 |   |   |   | C4 |   |   |   |
|   | 1   | 2 | 4 | 8 | 1  | 2 | 4 | 8 | 1  | 2 | 4 | 8 | 1  | 2 | 4 | 8 |
| 0 | ●   |   |   |   | ●  |   |   |   | ●  |   |   |   | ●  |   |   |   |
| 1 |   |   |   |   |    |   |   |   |    |   |   |   |    |   |   |   |
| 2 | ●   |   |   |   |    |   |   |   |    |   |   |   |    |   |   |   |
| 3 | ●   |   |   |   |    |   |   |   |    |   |   |   |    |   |   |   |
| 4 | ●   |   |   |   |    |   |   |   |    |   |   |   |    |   |   |   |
| 5 |   |   |   |   |    |   |   |   |    |   |   |   |    |   |   |   |
| 6 | ●   |   |   |   |    |   |   |   |    |   |   |   |    |   |   |   |
| 7 | ●   |   |   |   |    |   |   |   |    |   |   |   |    |   |   |   |
| 8 | ●   |   |   |   |    |   |   |   |    |   |   |   |    |   |   |   |
| 9 | ●   |   |   |   |    |   |   |   |    |   |   |   |    |   |   |   |



**F01**

BCD and Non-Shorting DECIMAL  
2 Pole 10 Position

D I A Common (C1) and (C2) connected to terminals indicated

|   |   |    |   |   |   |    |   |   |   |   |   |   |   |   |
|---|---|----|---|---|---|----|---|---|---|---|---|---|---|---|
| L |   | C1 |   |   |   | C2 |   |   |   |   |   |   |   |   |
|   | 1 | 2  | 4 | 8 | 0 | 1  | 2 | 3 | 4 | 5 | 6 | 7 | 8 | 9 |
| 0 |   |    |   |   | ● |    |   |   |   |   |   |   |   |   |
| 1 | ● |    |   |   |   | ●  |   |   |   |   |   |   |   |   |
| 2 |   | ●  |   |   |   |    | ● |   |   |   |   |   |   |   |
| 3 | ● | ●  |   |   |   |    |   | ● |   |   |   |   |   |   |
| 4 |   |    | ● |   |   |    |   |   | ● |   |   |   |   |   |
| 5 | ● |    |   |   |   |    |   |   |   | ● |   |   |   |   |
| 6 |   | ●  | ● |   |   |    |   |   |   |   | ● |   |   |   |
| 7 | ● | ●  | ● |   |   |    |   |   |   |   |   | ● |   |   |
| 8 |   |    |   | ● |   |    |   |   |   |   |   |   | ● |   |
| 9 | ● |    |   |   | ● |    |   |   |   |   |   |   |   | ● |

**G01**

1-2-2'-4 Berkeley Code  
1 Pole 10 Position

D I A Common (C) connected to terminals indicated

|   |   |   |    |   |
|---|---|---|----|---|
| L | 1 | 2 | 2' | 4 |
| 0 |   |   |    |   |
| 1 | ● |   |    |   |
| 2 |   | ● |    |   |
| 3 | ● | ● |    |   |
| 4 |   |   | ●  | ● |
| 5 | ● | ● | ●  |   |
| 6 |   | ● | ●  | ● |
| 7 | ● |   | ●  | ● |
| 8 | ● | ● | ●  | ● |
| 9 | ● | ● | ●  | ● |

**G02**

1-2-4-2' Berkeley Code  
1 Pole 10 Position

D I A Common (C) connected to terminals indicated

|   |   |   |   |    |
|---|---|---|---|----|
| L | 1 | 2 | 4 | 2' |
| 0 |   |   |   |    |
| 1 | ● |   |   |    |
| 2 |   | ● |   |    |
| 3 | ● | ● |   |    |
| 4 |   |   | ● |    |
| 5 | ● | ● | ● |    |
| 6 |   | ● | ● | ●  |
| 7 | ● |   | ● | ●  |
| 8 | ● | ● | ● | ●  |
| 9 | ● | ● | ● | ●  |

**H01**

1-2-4-2' Berkeley Code w/Complement  
1 Pole 10 Position

D I A Common (C) connected to terminals indicated

|   |   |   |   |    |   |   |   |    |
|---|---|---|---|----|---|---|---|----|
| L | 1 | 2 | 4 | 2' | 1 | 2 | 4 | 2' |
| 0 |   |   |   |    | ● | ● | ● | ●  |
| 1 | ● |   |   |    |   |   |   |    |
| 2 |   | ● |   |    |   |   |   |    |
| 3 | ● | ● |   |    |   |   |   |    |
| 4 |   |   | ● |    |   |   |   |    |
| 5 | ● | ● | ● |    |   |   |   |    |
| 6 |   | ● | ● | ●  |   |   |   |    |
| 7 | ● |   | ● | ●  |   |   |   |    |
| 8 | ● | ● | ● | ●  |   |   |   |    |
| 9 | ● | ● | ● | ●  |   |   |   |    |

**S01**

1 or 2 Pole 2 Throw  
Common (C1) and (C2) connected to terminals indicated

|      |    |    |    |    |
|------|----|----|----|----|
| DIAL |    | C1 | C2 |    |
|      | A1 | B1 | A2 | B2 |
| 0    | 0  | +  | ●  | ●  |
| 5    | 1  | -  | ●  | ●  |
| 0    | 0  | +  | ●  | ●  |
| 5    | 1  | -  | ●  | ●  |
| 0    | 0  | +  | ●  | ●  |
| 5    | 1  | -  | ●  | ●  |
| 0    | 0  | +  | ●  | ●  |
| 5    | 1  | -  | ●  | ●  |
| 0    | 0  | +  | ●  | ●  |
| 5    | 1  | -  | ●  | ●  |

**S03**

5-Line TELETYPE  
1 Pole 10 Position

D I A Common (C) connected to terminals indicated

|   |   |   |   |   |   |
|---|---|---|---|---|---|
| L | 1 | 2 | 3 | 4 | 5 |
| 0 | ● | ● | ● | ● | ● |
| 1 | ● | ● | ● | ● | ● |
| 2 | ● | ● | ● | ● | ● |
| 3 | ● | ● | ● | ● | ● |
| 4 |   | ● |   | ● |   |
| 5 |   |   | ● |   | ● |
| 6 | ● |   | ● |   | ● |
| 7 | ● | ● | ● | ● | ● |
| 8 | ● | ● | ● | ● | ● |
| 9 |   |   | ● |   | ● |

**S04**

5-Line TELETYPE w/even bit parity  
1 Pole 10 Position

D I A Common (C) connected to terminals indicated

|   |   |   |   |   |   |   |
|---|---|---|---|---|---|---|
| L | 1 | 2 | 3 | 4 | 5 | P |
| 0 | ● | ● | ● | ● | ● | ● |
| 1 | ● | ● | ● | ● | ● | ● |
| 2 | ● | ● | ● | ● | ● | ● |
| 3 | ● | ● | ● | ● | ● | ● |
| 4 |   | ● |   | ● |   | ● |
| 5 |   |   | ● |   | ● |   |
| 6 | ● |   | ● |   | ● | ● |
| 7 | ● | ● | ● | ● | ● | ● |
| 8 | ● | ● | ● | ● | ● | ● |
| 9 |   |   | ● |   | ● |   |

**S05**

BIQUINARY  
1 Pole 10 Position

D I A Common (C) connected to terminals indicated

|   |     |      |     |     |     |     |     |
|---|-----|------|-----|-----|-----|-----|-----|
| L | ODD | EVEN | 0,1 | 2,3 | 4,5 | 6,7 | 8,9 |
| 0 |     | ●    |     | ●   |     | ●   |     |
| 1 | ●   |      | ●   |     | ●   |     | ●   |
| 2 |     | ●    |     | ●   |     | ●   |     |
| 3 | ●   |      | ●   |     | ●   |     | ●   |
| 4 |     | ●    |     | ●   |     | ●   |     |
| 5 | ●   |      | ●   |     | ●   |     | ●   |
| 6 |     | ●    |     | ●   |     | ●   |     |
| 7 | ●   |      | ●   |     | ●   |     | ●   |
| 8 |     | ●    |     | ●   |     | ●   |     |
| 9 | ●   |      | ●   |     | ●   |     | ●   |

**S06**

NOT/NOR SWITCH 1 Pole 12 Position  
(All Positions Shorted except Position indicated on Dial)

D I A Common (C) connected to terminals indicated

|    |   |   |   |   |   |   |   |   |   |   |    |    |
|----|---|---|---|---|---|---|---|---|---|---|----|----|
| L  | 0 | 1 | 2 | 3 | 4 | 5 | 6 | 7 | 8 | 9 | 10 | 11 |
| 0  |   | ● | ● | ● | ● | ● | ● | ● | ● | ● | ●  | ●  |
| 1  | ● |   | ● | ● | ● | ● | ● | ● | ● | ● | ●  | ●  |
| 2  |   | ● |   | ● | ● | ● | ● | ● | ● | ● | ●  | ●  |
| 3  | ● | ● |   | ● | ● | ● | ● | ● | ● | ● | ●  | ●  |
| 4  |   | ● | ● |   | ● | ● | ● | ● | ● | ● | ●  | ●  |
| 5  | ● | ● | ● |   | ● | ● | ● | ● | ● | ● | ●  | ●  |
| 6  |   | ● | ● | ● |   | ● | ● | ● | ● | ● | ●  | ●  |
| 7  | ● | ● | ● | ● |   | ● | ● | ● | ● | ● | ●  | ●  |
| 8  |   | ● | ● | ● | ● |   | ● | ● | ● | ● | ●  | ●  |
| 9  | ● | ● | ● | ● | ● |   | ● | ● | ● | ● | ●  | ●  |
| 10 |   | ● | ● | ● | ● | ● |   | ● | ● | ● | ●  | ●  |
| 11 | ● | ● | ● | ● | ● | ● | ● |   | ● | ● | ●  | ●  |

**S07**

INCREMENTAL Voltage Divider  
2 Pole 10 Position

D I A Pins 1 and 2 connected across resistor indicated

|   |    |    |    |    |    |    |    |    |    |    |
|---|----|----|----|----|----|----|----|----|----|----|
| L | R0 | R1 | R2 | R3 | R4 | R5 | R6 | R7 | R8 | R9 |
| 0 | ●  |    |    |    |    |    |    |    |    |    |
| 1 |    | ●  |    |    |    |    |    |    |    |    |
| 2 |    |    | ●  |    |    |    |    |    |    |    |
| 3 |    |    |    | ●  |    |    |    |    |    |    |
| 4 |    |    |    |    | ●  |    |    |    |    |    |
| 5 |    |    |    |    |    | ●  |    |    |    |    |
| 6 |    |    |    |    |    |    | ●  |    |    |    |
| 7 |    |    |    |    |    |    |    | ●  |    |    |
| 8 |    |    |    |    |    |    |    |    | ●  |    |
| 9 |    |    |    |    |    |    |    |    |    | ●  |

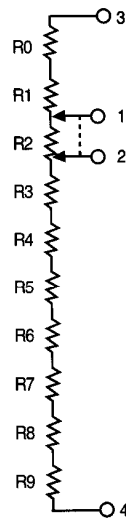

SCHEMATIC  
Dial set at  
Position no. 2

**S08**

WOLFF POGGENDORF Voltage Divider  
10 Position

D I A Resistors in circuit

|   |   |   |   |    |   |   |   |    |
|---|---|---|---|----|---|---|---|----|
| L | 1 | 2 | 4 | 2' | 1 | 2 | 4 | 2' |
| 0 | ● | ● | ● | ●  |   |   |   | ●  |
| 1 |   | ● | ● | ●  | ● |   |   | ●  |
| 2 |   |   | ● | ●  | ● | ● |   | ●  |
| 3 |   |   |   | ●  | ● | ● | ● | ●  |
| 4 | ● | ● | ● |    | ● | ● | ● | ●  |
| 5 |   | ● | ● | ●  |   | ● | ● | ●  |
| 6 | ● |   | ● | ●  | ● |   | ● | ●  |
| 7 |   |   | ● | ●  | ● | ● |   | ●  |
| 8 | ● | ● | ● | ●  | ● | ● | ● | ●  |
| 9 |   |   | ● | ●  | ● | ● | ● | ●  |

**S09**

CAPACITOR DECADE  
1-2-3-4 Code 10 Position

D I A Capacitors in Circuit

|   |    |    |    |    |
|---|----|----|----|----|
| L | C1 | C2 | C3 | C4 |
| 0 |    |    |    |    |
| 1 | ●  |    |    |    |
| 2 |    | ●  |    |    |
| 3 |    |    | ●  |    |
| 4 |    |    |    | ●  |
| 5 | ●  | ●  | ●  | ●  |
| 6 |    | ●  | ●  | ●  |
| 7 | ●  |    | ●  | ●  |
| 8 | ●  | ●  | ●  | ●  |
| 9 | ●  | ●  | ●  | ●  |

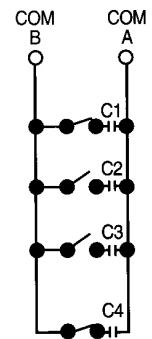

SCHEMATIC  
Dial set at Position no. 5  
(C1 and C4 Active)



**S10**  
RESISTOR DECADE  
1-2-3-6 Code 10 Position

|   |                      |    |    |    |   |   |
|---|----------------------|----|----|----|---|---|
| D | Resistors in circuit |    |    |    |   |   |
| I |                      |    |    |    |   |   |
| A |                      |    |    |    |   |   |
| L | R1                   | R2 | R3 | R6 |   |   |
| 0 | ●                    |    |    |    |   |   |
| 1 | ●                    |    |    |    |   |   |
| 2 | ●                    |    |    |    |   |   |
| 3 | ●                    | ●  |    |    |   |   |
| 4 | ●                    | ●  | ●  |    |   |   |
| 5 | ●                    | ●  | ●  | ●  |   |   |
| 6 | ●                    | ●  | ●  | ●  | ● |   |
| 7 | ●                    | ●  | ●  | ●  | ● | ● |
| 8 | ●                    | ●  | ●  | ●  | ● | ● |
| 9 | ●                    | ●  | ●  | ●  | ● | ● |

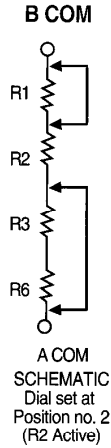

**S11**  
7 BAR INDICATOR  
1 Pole 10 Position

|   |   |   |   |   |   |   |   |
|---|---|---|---|---|---|---|---|
| D | Common connected to terminals indicated |   |   |   |   |   |   |
| I |   |   |   |   |   |   |   |
| A | A                                       | B | C | D | E | F | G |
| L |   |   |   |   |   |   |   |
| 0 | ●                                       | ● |   | ● | ● | ● | ● |
| 1 | ●                                       | ● | ● | ● | ● | ● | ● |
| 2 | ●                                       | ● | ● | ● | ● | ● | ● |
| 3 | ●                                       | ● | ● | ● | ● | ● | ● |
| 4 | ●                                       | ● | ● | ● | ● | ● | ● |
| 5 | ●                                       | ● | ● | ● | ● | ● | ● |
| 6 | ●                                       | ● | ● | ● | ● | ● | ● |
| 7 | ●                                       | ● | ● | ● | ● | ● | ● |
| 8 | ●                                       | ● | ● | ● | ● | ● | ● |
| 9 | ●                                       | ● | ● | ● | ● | ● | ● |

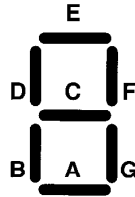

**S12**  
KELVIN VARLEY: Voltage Divider  
10 Position

|   |   |    |    |    |    |    |    |    |    |    |     |
|---|---|----|----|----|----|----|----|----|----|----|-----|
| D | Pins 1 and 2 connected across resistors indicated |    |    |    |    |    |    |    |    |    |     |
| I |   |    |    |    |    |    |    |    |    |    |     |
| A |   |    |    |    |    |    |    |    |    |    |     |
| L | R0  | R1 | R2 | R3 | R4 | R5 | R6 | R7 | R8 | R9 | R10 |
| 0 | ●   | ●  |    |    |    |    |    |    |    |    |     |
| 1 | ●   | ●  | ●  |    |    |    |    |    |    |    |     |
| 2 | ●   | ●  | ●  | ●  |    |    |    |    |    |    |     |
| 3 | ●   | ●  | ●  | ●  | ●  |    |    |    |    |    |     |
| 4 | ●   | ●  | ●  | ●  | ●  | ●  |    |    |    |    |     |
| 5 | ●   | ●  | ●  | ●  | ●  | ●  | ●  |    |    |    |     |
| 6 | ●   | ●  | ●  | ●  | ●  | ●  | ●  | ●  |    |    |     |
| 7 | ●   | ●  | ●  | ●  | ●  | ●  | ●  | ●  | ●  |    |     |
| 8 | ●   | ●  | ●  | ●  | ●  | ●  | ●  | ●  | ●  | ●  |     |
| 9 | ●   | ●  | ●  | ●  | ●  | ●  | ●  | ●  | ●  | ●  | ●   |

**S15**  
Modified 5 Bit TELETYPE  
10 Position

|   |   |   |   |   |   |
|---|---|---|---|---|---|
| D | Common (C) connected to terminals indicated |   |   |   |   |
| I |   |   |   |   |   |
| A |   |   |   |   |   |
| L | 1   | 2 | 3 | 4 | 5 |
| 0 | ●   | ● | ● | ● | ● |
| 1 | ●   | ● | ● | ● | ● |
| 2 | ●   | ● | ● | ● | ● |
| 3 | ●   | ● | ● | ● | ● |
| 4 | ●   | ● | ● | ● | ● |
| 5 | ●   | ● | ● | ● | ● |
| 6 | ●   | ● | ● | ● | ● |
| 7 | ●   | ● | ● | ● | ● |
| 8 | ●   | ● | ● | ● | ● |
| 9 | ●   | ● | ● | ● | ● |

**S17**  
Resistor DECADE  
1-2-4-2' Code 10 Position

|   |                      |    |    |     |   |
|---|----------------------|----|----|-----|---|
| D | Resistors in circuit |    |    |     |   |
| I |                      |    |    |     |   |
| A |                      |    |    |     |   |
| L | R1                   | R2 | R4 | R2' |   |
| 0 | ●                    |    |    |     |   |
| 1 | ●                    |    |    |     |   |
| 2 | ●                    | ●  |    |     |   |
| 3 | ●                    | ●  | ●  |     |   |
| 4 | ●                    | ●  | ●  | ●   |   |
| 5 | ●                    | ●  | ●  | ●   | ● |
| 6 | ●                    | ●  | ●  | ●   | ● |
| 7 | ●                    | ●  | ●  | ●   | ● |
| 8 | ●                    | ●  | ●  | ●   | ● |
| 9 | ●                    | ●  | ●  | ●   | ● |

**S18**  
Resistor DECADE  
1-2-2-2 Code 10 Position

|   |                      |    |    |    |    |
|---|----------------------|----|----|----|----|
| D | Resistors in circuit |    |    |    |    |
| I |                      |    |    |    |    |
| A |                      |    |    |    |    |
| L | R1                   | R2 | R3 | R4 | R5 |
| 0 | ●                    |    |    |    |    |
| 1 | ●                    |    |    |    |    |
| 2 | ●                    | ●  |    |    | ●  |
| 3 | ●                    | ●  | ●  |    | ●  |
| 4 | ●                    | ●  | ●  | ●  | ●  |
| 5 | ●                    | ●  | ●  | ●  | ●  |
| 6 | ●                    | ●  | ●  | ●  | ●  |
| 7 | ●                    | ●  | ●  | ●  | ●  |
| 8 | ●                    | ●  | ●  | ●  | ●  |
| 9 | ●                    | ●  | ●  | ●  | ●  |

**S19**  
2 Pole 2 Throw  
Commons C(●) and C(\*) connected to terminals indicated

|      |         |   |
|------|---------|---|
| DIAL | A       | B |
| 0    | 0 + ● ★ |   |
| 1    | 5 - ★ ● |   |
| 0    | 0 + ● ★ |   |
| 1    | 5 - ★ ● |   |
| 0    | 0 + ● ★ |   |
| 1    | 5 - ★ ● |   |
| 0    | 0 + ● ★ |   |
| 1    | 5 - ★ ● |   |
| 0    | 0 + ● ★ |   |
| 1    | 5 - ★ ● |   |

**S20**  
2 Pole 1-1'-2-5 with Complement  
Commons (C) and C' connected to terminals indicated

|      |   |    |
|------|---|----|
| DIAL | C | C' |
| 0    | ● | ●  |
| 1    | ● | ●  |
| 2    | ● | ●  |
| 3    | ● | ●  |
| 4    | ● | ●  |
| 5    | ● | ●  |
| 6    | ● | ●  |
| 7    | ● | ●  |
| 8    | ● | ●  |
| 9    | ● | ●  |

**S21**  
EECO Voltage Divider (THUMB POT) 10 Position

|   |   |    |    |    |  |    |    |    |
|---|---|----|----|----|--|----|----|----|
| D | Resistors in circuit between term 2 & 5 |    |    |    | Resistors in circuit between term 8 & 11 |    |    |    |
| I |   |    |    |    |  |    |    |    |
| A |   |    |    |    |  |    |    |    |
| L | 4                                       | 2  | 1  | 2' | 4  | 2  | 1  | 2' |
|   | R1                                      | R2 | R3 | R4 | R1                                       | R2 | R3 | R4 |
| 0 |   |    |    |    | ●  | ●  | ●  | ●  |
| 1 | ●                                       |    |    |    | ●  | ●  | ●  | ●  |
| 2 | ●                                       | ●  |    |    | ●  | ●  | ●  | ●  |
| 3 | ●                                       | ●  | ●  |    | ●  | ●  | ●  | ●  |
| 4 | ●                                       | ●  | ●  | ●  | ●  | ●  | ●  | ●  |
| 5 | ●                                       | ●  | ●  | ●  | ●  | ●  | ●  | ●  |
| 6 | ●                                       | ●  | ●  | ●  | ●  | ●  | ●  | ●  |
| 7 | ●                                       | ●  | ●  | ●  | ●  | ●  | ●  | ●  |
| 8 | ●                                       | ●  | ●  | ●  | ●  | ●  | ●  | ●  |
| 9 | ●                                       | ●  | ●  | ●  | ●  | ●  | ●  | ●  |

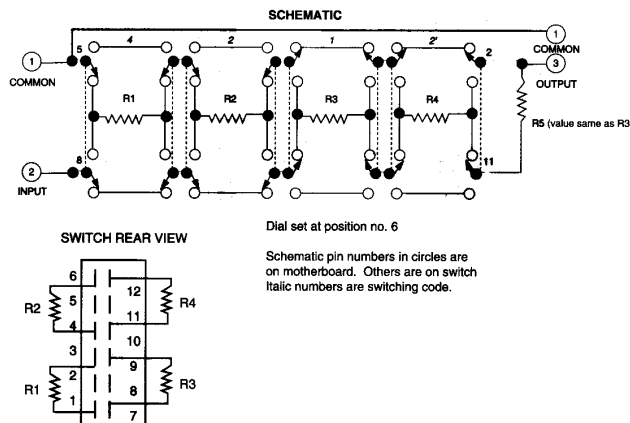

**S22**  
1-2-4-5 Code  
Common (C) connected to terminals indicated

|      |   |   |   |   |
|------|---|---|---|---|
| DIAL | 1 | 2 | 4 | 5 |
| 0    | ● |   |   |   |
| 1    | ● | ● |   |   |
| 2    | ● | ● | ● |   |
| 3    | ● | ● | ● | ● |
| 4    | ● | ● | ● | ● |
| 5    | ● | ● | ● | ● |
| 6    | ● | ● | ● | ● |
| 7    | ● | ● | ● | ● |
| 8    | ● | ● | ● | ● |
| 9    | ● | ● | ● | ● |

**S23**  
JOHNSON CODE  
Common (C) connected to terminals indicated

|      |   |   |   |   |   |
|------|---|---|---|---|---|
| DIAL | A | B | C | D | E |
| 0    | ● | ● | ● | ● | ● |
| 1    | ● | ● | ● | ● | ● |
| 2    | ● | ● | ● | ● | ● |
| 3    | ● | ● | ● | ● | ● |
| 4    | ● | ● | ● | ● | ● |
| 5    | ● | ● | ● | ● | ● |
| 6    | ● | ● | ● | ● | ● |
| 7    | ● | ● | ● | ● | ● |
| 8    | ● | ● | ● | ● | ● |
| 9    | ● | ● | ● | ● | ● |

Consult factory for additional information.



# THUMB POT™ SERIES THUMB POT VOLTAGE DIVIDERS

*EECO's THUMB POT™ is a digital voltage divider which allows the user to set varying voltages while maintaining a constant resistance within the circuit.*

Sharing many of the features and options of our 1776 and 1976 Series switches, the THUMB POT is available in 2, 3, or 4 decade models, with resistance values from 1,000 to 100,000 ohms. The THUMB POT is based on a proprietary circuit developed by EECO, using matched resistor pairs. Unlike rotary or dial potentiometers, the THUMB POT offers exact setting repeatability, with setting accuracy as precise as ± 0.05% of full scale voltage.

The THUMB POT is covered by EECO's one-year warranty.

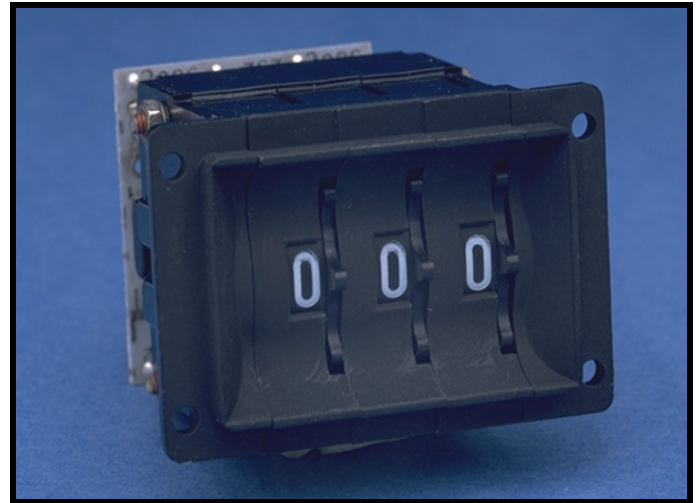

## SPECIFICATIONS

### MECHANICAL

|                            |  |
|----------------------------|--|
| No. of Switching Positions | 10   |
| Life                       | Minimum 1,000,000 Detents @ 10 mA, 5VDC, +25°C |
| Tangential Operating Force | 5-18 Oz.                                       |
| Weight                     | (Approx.) 0.4 Oz Per Decade                    |

### ELECTRICAL

|   |                                |
|---|--------------------------------|
| Standard Resistance Range                             | 1,000 to 100,000Ω              |
| Standard Resistance Tolerance                         | ± 1%                           |
| Setting Accuracy                                      | To 0.05% of Full Scale Voltage |
| Standard Input Voltages (Function Of Input Impedance) |                                |
| 1,000 To 5,000 Ω Input Impedance                      | 16 Volts @ 25°C                |
| 10,000 To 50,000 Ω Input Impedance                    | 50 Volts @ 25°C                |
| 100,000 Ω Input Impedance                             | 150 Volts @ 25°C               |
| Insulation Resistance                                 | 1,000M Ω Minimum               |
| Dielectric Withstanding Voltage                       | 500 VAC (RMS)                  |

### ENVIRONMENTAL

|                       |                |
|-----------------------|----------------|
| Operating Temperature | -20°C To +75°C |
| Seal                  | Dust Resistant |

### MATERIALS

|                         |  |
|-------------------------|--|
| Plastic                 | Polycarbonate per Federal Spec LP-393A |
| Metals                  | Corrosion Resistant                    |
| Circuit Disc - Material | Glass Epoxy                            |
| Plating                 | Gold Over Nickel Plating               |
| Terminals               | Copper Alloy, Plated for Soldering     |
| Contacts                | Copper Alloy, Gold Over Nickel Plating |

### RoHS COMPLIANCE

EECO Switch is fully committed to complying with the European Lead-Free and RoHS directives. Consult the factory for the RoHS status of this product.



**OUTLINE DIMENSIONS AND PANEL MOUNTING INFORMATION**

**1776 MODEL**

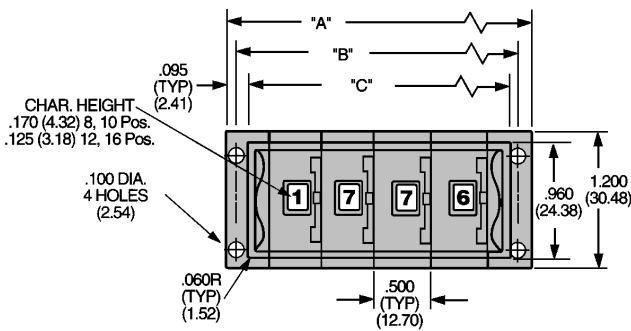
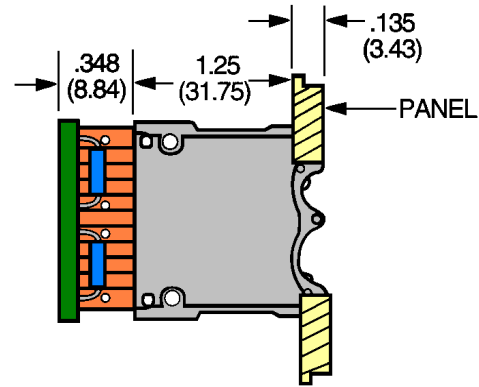
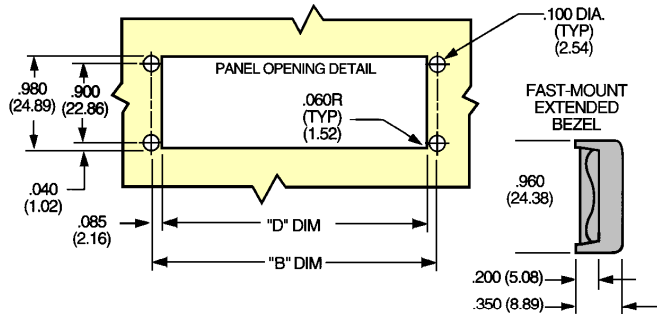

**MOUNTING DIMENSIONS 76 SERIES**

| NO. OF DECADES | A              | B              | C              | D              |
|----------------|----------------|----------------|----------------|----------------|
| 2              | 1.76<br>(44.7) | 1.59<br>(40.4) | 1.40<br>(35.6) | 1.42<br>(36.1) |
| 3              | 2.26<br>(57.4) | 2.09<br>(53.1) | 1.90<br>(48.3) | 1.92<br>(48.8) |
| 4              | 2.76<br>(70.1) | 2.59<br>(65.8) | 2.40<br>(61.0) | 2.42<br>(61.5) |

Assembly dimensions may exhibit expansion of 0.003" per station before installation, but will adjust to recommended panel dimensions shown once installed.  
Tolerances .XXX ± 0.010", .XX ± 0.030.  
( ) Metric equivalents in mm.

**1976 MODEL**

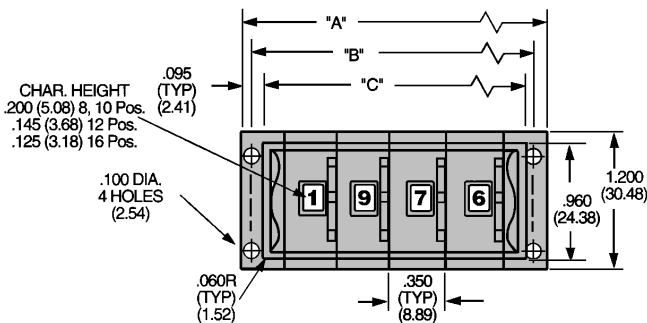
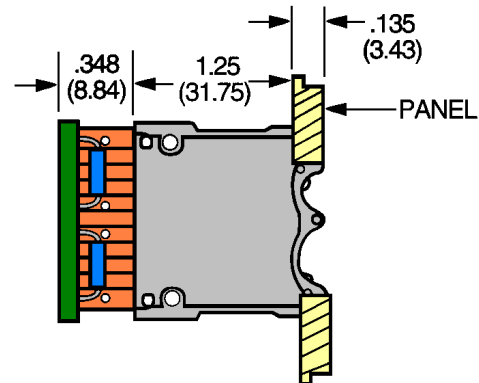
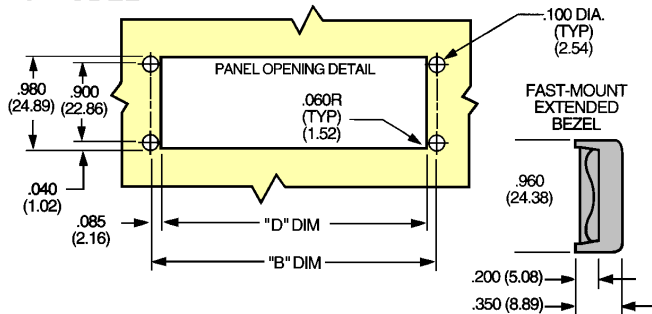

**MOUNTING DIMENSIONS 96 SERIES**

| NO. OF DECADES | A              | B              | C              | D              |
|----------------|----------------|----------------|----------------|----------------|
| 2              | 1.46<br>(37.1) | 1.29<br>(32.8) | 1.10<br>(27.9) | 1.12<br>(28.4) |
| 3              | 1.81<br>(46.0) | 1.64<br>(41.7) | 1.45<br>(36.8) | 1.47<br>(37.3) |
| 4              | 2.16<br>(54.9) | 1.99<br>(50.5) | 1.80<br>(45.7) | 1.82<br>(46.2) |

Assembly dimensions may exhibit expansion of 0.003" per station before installation, but will adjust to recommended panel dimensions shown once installed.  
Tolerances .XXX ± 0.010", .XX ± 0.030.  
( ) Metric equivalents in mm.

## SCHEMATIC AND TERMINAL INFORMATION

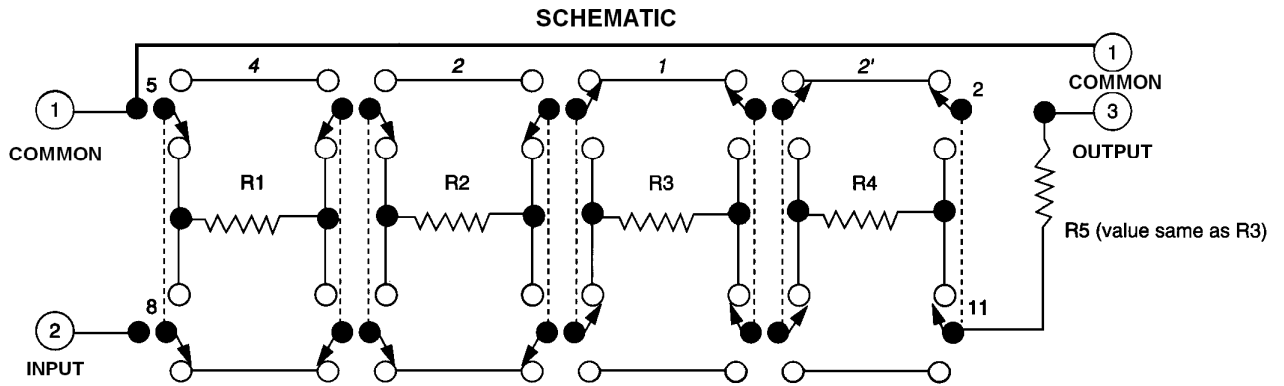

Dial set at position 6  
 Schematic pin numbers in circles are located on motherboard. Other numbers refer to switch terminals. Italic numbers refer to resistor values.

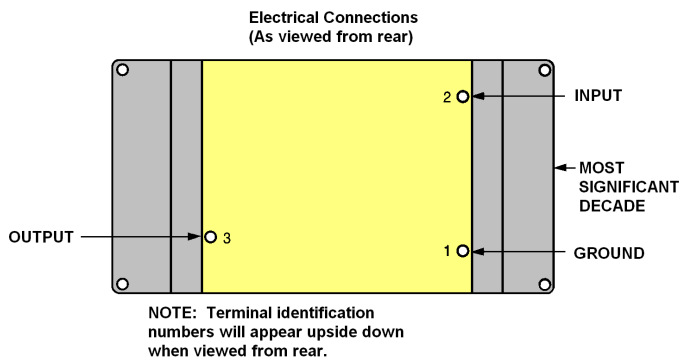

### S21

| EECO Thumbpot Voltage Divider<br>10 Position |  |         |         |          |   |         |         |           |
|--|--|---------|---------|----------|---|---------|---------|-----------|
| D<br>I<br>A<br>L                             | Resistors in circuit<br>between terminals<br>2 and 5 |         |         |          | Resistors in circuit<br>between terminals<br>8 and 11 |         |         |           |
|  | 4<br>R1  | 2<br>R2 | 1<br>R3 | 2'<br>R4 | 4<br>R1   | 2<br>R2 | 1<br>R3 | 2''<br>R4 |
| 0  |  |         |         |          | ●   | ●       | ●       | ●         |
| 1  |  |         | ●       |          | ●   | ●       |         | ●         |
| 2  |  | ●       |         |          | ●   |         | ●       | ●         |
| 3  |  |         | ●       | ●        | ●   | ●       |         |           |
| 4  | ●  |         |         |          |   | ●       | ●       | ●         |
| 5  | ●  |         | ●       |          |   | ●       |         | ●         |
| 6  | ●  | ●       |         |          |   |         | ●       | ●         |
| 7  | ●  | ●       | ●       |          |   |         |         | ●         |
| 8  | ●  | ●       |         | ●        |   |         | ●       |           |
| 9  | ●  | ●       | ●       | ●        |   |         |         |           |



### OPTIONS AND ORDERING INFORMATION

#### AVAILABLE OPTIONS

- D** Decimal Point
- G** Gloss Finish (Standard)
- M** Spray Matte Finish
- P** +/- Rotor Marking
- T** Alphabet Marking
- U** EMI/RFI Shielding
- Y** Fast Mount Hardware (applies to assembly part number)  
Stop Pins  
Consult Factory for Custom Rotor Marking or Other Special Requests

| INPUT RESISTANCE | RESISTANCE AND ACCURACY DESIGNATORS                    |                 |                 |                 |                 |
|------------------|--|-----------------|-----------------|-----------------|-----------------|
|                  | SETTING ACCURACY<br>(AS % OF FULL SCALE INPUT VOLTAGE) |                 |                 |                 |                 |
|                  | 1%   | .5%             | .25%†           | .10%†           | .05%†           |
| 100,000 Ω ± 1%   | 01   | 05              | 09              | 13              | 17              |
| 50,000 Ω ± 1%    | 29   | 32              | 35              | 38              | 41              |
| 10,000 Ω ± 1%    | 02   | 06              | 10              | 14              | 18              |
| 5,000 Ω ± 1%     | 30   | 33              | 36              | 39              | 42              |
| 1,000 Ω ± 1%     | 03 <sup>1</sup>  | 07 <sup>1</sup> | 11 <sup>1</sup> | 15 <sup>1</sup> | 19 <sup>1</sup> |

| DEVICE RESOLUTION | PART NO. PREFIX |
|-------------------|-----------------|
| 1.0 (2 Decades)   | 2W76 or 2W96    |
| 0.1 (3 Decades)   | 3W76 or 3W96    |
| 0.01 (4 Decades)  | 4W76 or 4W96    |

#### THUMBPOW ORDERING NOTES

- 1.<sup>1</sup> Not available on 4 decade models.
2. † Models are limited availability. Consult factory for additional information.
3. Values shown above are for linearity as defined by VRCI-P-100A. "Terminal-based", "Zero-based" and "Independent" linearity specifications are available. Consult factory for additional information.

#### ORDERING EXAMPLE - THUMBPOW ASSEMBLY

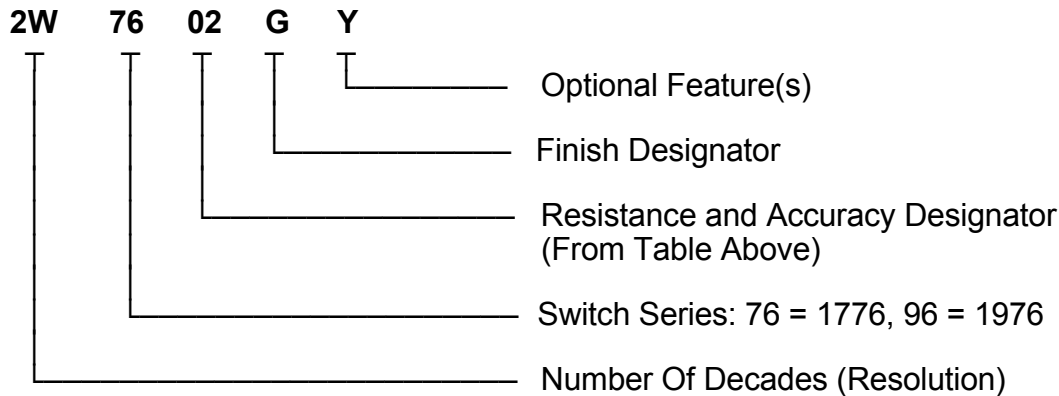

Certain combinations of options may require a special part number. Consult factory for additional information.