

Mylar Speaker (External Magnet)

Model: ME102TS-37H10W4N



ELECTRICAL SPECIFICATIONS

	Condition	Parameter	Unit
Sound Pressure Level	at 0.1W, 0.1M [at 0.6, 0.8, 1.0, 1.2KHz]	91 ± 3	dB
Impedance	at 1V, 1000Hz	4 ± 15%	Ω
Rated Input Power		10	W
Max Input Power		12	W
Resonant Frequency (Fo)	at 1V	300 ± 20%	Hz
Frequency Range		Fo ~ 5000	Hz
Buzzer & Rattles	not be audible at sine wave between Fo ~ 5KHz	6.32	V
Operating Temperature		-30 ~ 60	°C
Magnet		Ferrite	
Frame Material		Metal	
Cone Material		Mylar (PET)	
Weight		252	g

MECHANICAL DRAWING

Dimensions in mm

Tolerance ±0.5mm Except Specified

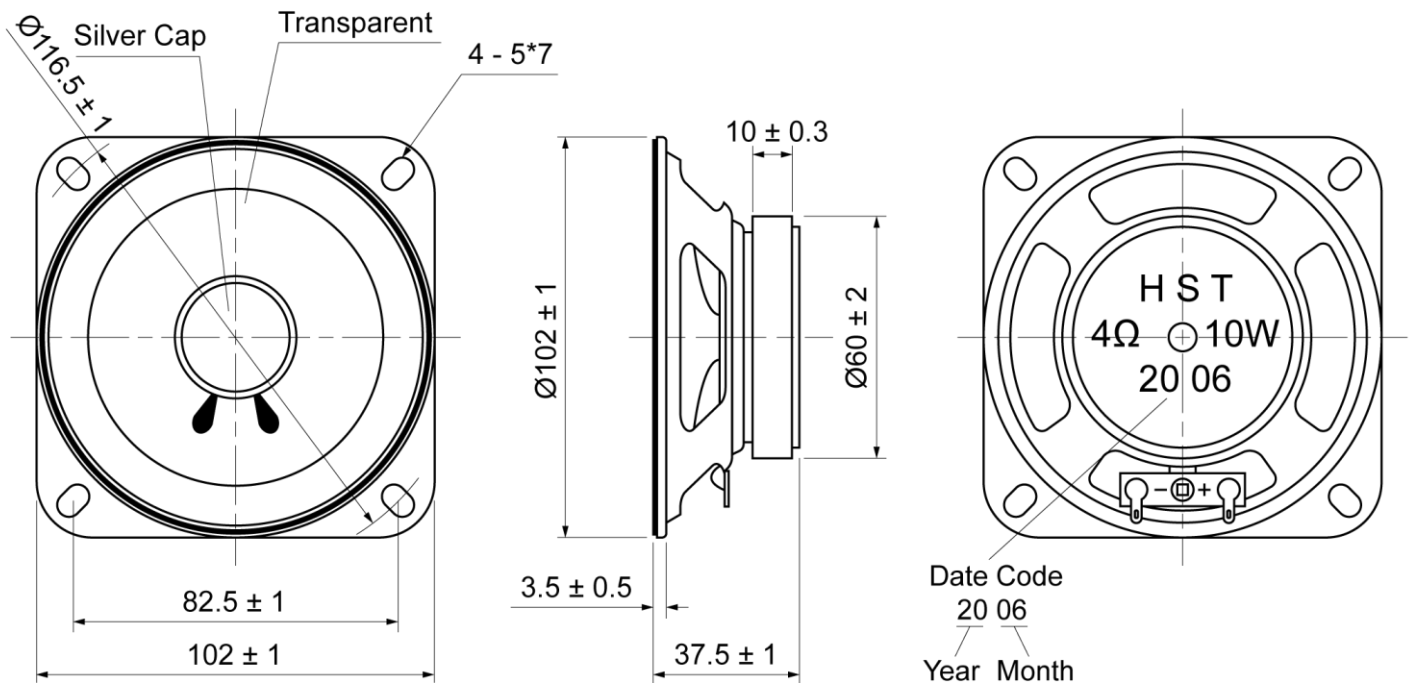

Mylar Speaker (External Magnet)

Model: ME102TS-37H10W4N

FREQUENCY RESPONSE CURVE

