

**Piezo Transducer (External Drive)**

**Model: XPT5421-X364**



**ELECTRICAL SPECIFICATIONS**

	Condition	Parameter	Unit
Operating Voltage		1 ~ 30	Vp-p
Rated Voltage		12	Vp-p
Rated Current	at rated voltage, resonant freq., square wave	Max. 7	mA
Capacitance	at 1000Hz	33000 ± 30%	pF
Resonant Frequency		3400	Hz
Sound Pressure Level	at 10cm, rated voltage, resonant freq., square wave	Min. 98	dBa
Terminal		Connector	
Operating Temperature		-20 ~ +60	°C
Housing Material		ABS (Black+Red)	
Weight		21	g

**MECHANICAL DRAWING**

Dimensions in mm

Wire: UL1571 26AWG

Tolerance ±0.5mm Except Specified

Connector: JST PH 2.0

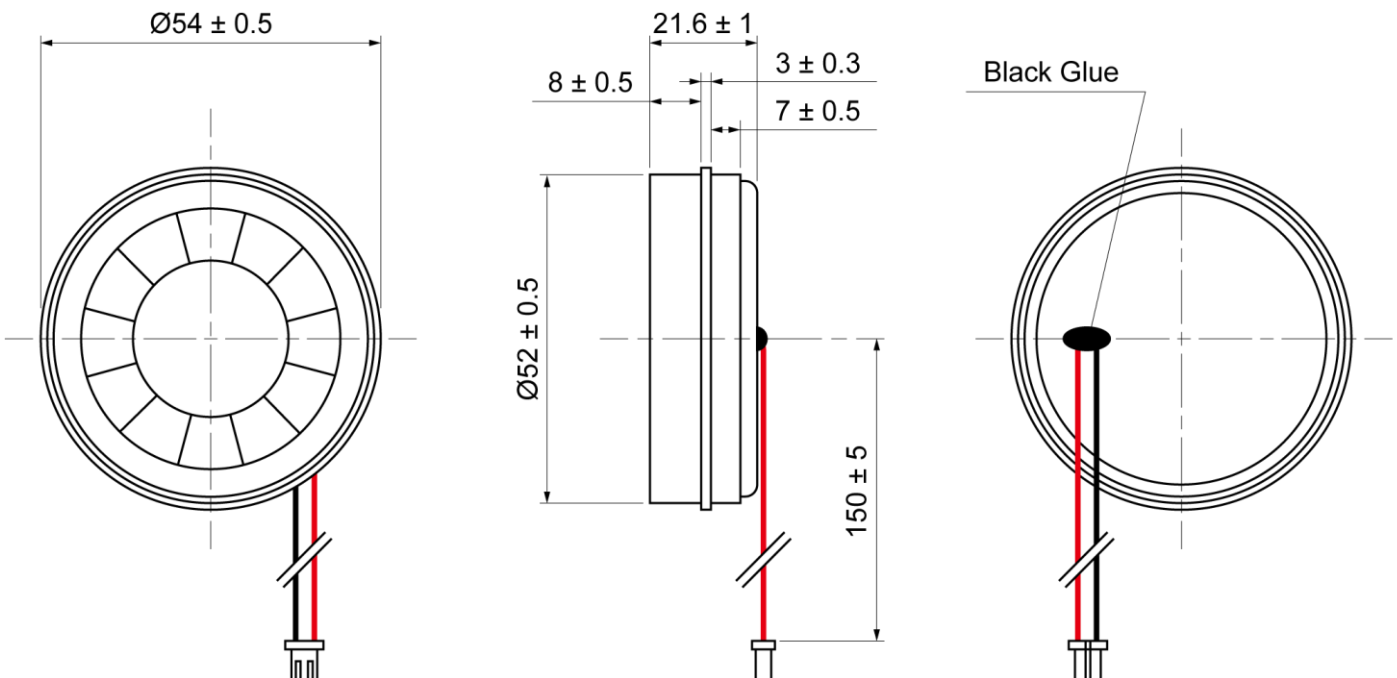

**Piezo Transducer (External Drive)**

**Model: XPT5421-X364**

**REVISION HISTORY**

---

<b>Ver</b>	<b>Description</b>	<b>Date</b>
1.0	initial release	16 Dec 2022