

Metal Oxide Varistor: TVR-M Series

Dip Type Varistor for 48Vdc Architecture of Vehicle's Electrical Systems



■ Feature

1. Designed for 48Vdc architecture of vehicle's electrical systems
2. Superior resistance to cyclic temperature
3. High operating temperature range up to 125 °C
4. Agency approval: UL, TUV, CQC
5. AEC-Q 200 qualified
6. First UL 1449A approval part in the world

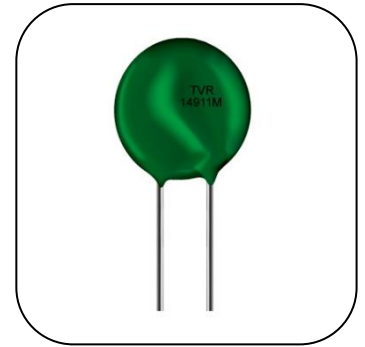

■ Recommended Applications

1. 48Vdc automotive devices
2. Telecom infrastructure devices
3. Industrial power and devices

■ Part Number Code

T	V	R	1	0	1	5	1	K	L			Q	0	0	M
1	2	3	4	5	6	7	8	9	10	11	12	13	14	15	16

Product Type		Body Size		Varistor Voltage (V _{1mA})		Tolerance of V _{1mA}		Appearance		Packaging		Optional Suffix	
TVR	THINKING Varistor TVR Series	10	Φ10mm	820	82x10 ⁰ V=82V	K	±10%	L	Straight lead, silicon coating	AR	Tape & reel packing (hole pitch:12.7mm)	M	Varistor for automotive applications (When internal control code is used)
		14	Φ14mm	151	15x10 ¹ V=150V	L	±15%	W	Outer kink lead, silicon coating	ER	Tape & reel packing (hole pitch:15.0mm)		
		20	Φ20mm			M	±20%			AB	Tape & ammo box packing (hole pitch:12.7mm)		
										EB	Tape & ammo box packing (hole pitch:15.0mm)		
										C	Bulk & cut lead (followed by the codes of 2 leaded length)		
										Blank	Bulk		

Internal Control Code	
Q00-QZZ	

Metal Oxide Varistor: TVR-M Series

Dip Type Varistor for 48Vdc Architecture of Vehicle's Electrical Systems



Structure & Dimensions

L Type (Straight Lead)

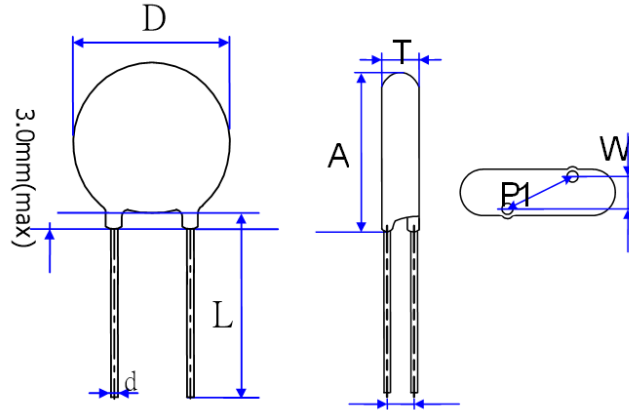

(Unit: mm)

Series	Dmax.	Amax.	Lmin	$\Phi d \pm 0.02$	$P1 \pm 1.0$	T & W
TVR10-M	14.4	15.0	26.5	0.8	7.5	Please refer to Electrical Characteristics Table
TVR14-M	18.0	18.5	26.5	0.8	7.5	
TVR20-M	24.0	25.5	22.5	1.0	10.0	

W Type (Outer Kink Lead)

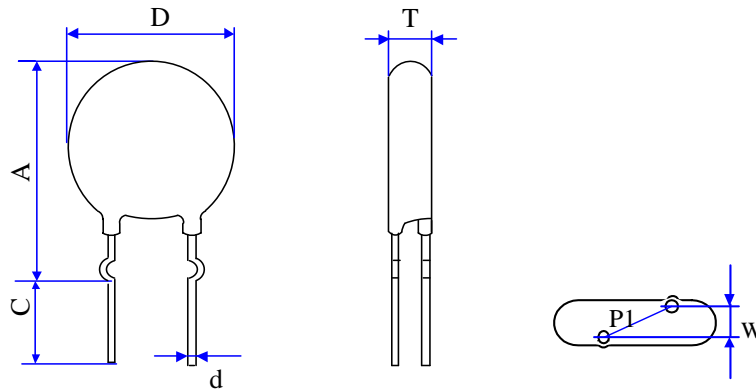

(Unit: mm)

Series	Dmax.	Amax.	Cmin	$\Phi d \pm 0.02$	$P1 \pm 1.0$	T & W
TVR10-M	14.4	20.0	20	0.8	7.5	Please refer to Electrical Characteristics Table
TVR14-M	18.0	22.5	20	0.8	7.5	

Note: Size of C is customized, and tolerance of cut lead product is ± 0.5 (Please refer to minimal size in the chart above if customers do not request). Popular minimal size of cut lead products is 3.5 ± 0.5 mm.

Metal Oxide Varistor: TVR-M Series

Dip Type Varistor for 48Vdc Architecture of Vehicle's Electrical Systems



■ Electrical Characteristics

For 48Vdc Architecture of Vehicle's Electrical Systems



Part No.	Varistor Voltage (@ 1mA DC)	Max. Continuous Voltage		Max. Clamping Voltage (8/20 μ s)		Max. Surge Current (8/20 μ s)	Rated Power	Max. Energy (10/1000 μ s)	Dimension		
	V _{1mA}	V _{ac}	V _{dc}	V _P	I _p	I _{max}	P	W _{max}	T _{min}	T _{max}	W \pm 1
	(V)	(V)	(V)	(V)	(A)	(A)	(W)	(J)	(mm)		
TVR10820-M	82 \pm 10%	50	65	135	25	3500	0.4	14	2.56	5.34	1.6
TVR10101-M	100 \pm 10%	60	85	165	25	3500	0.4	17	2.58	5.35	1.7
TVR10121-M	120 \pm 10%	75	100	200	25	3500	0.4	20	2.6	5.36	1.8
TVR10151-M	150 \pm 10%	95	125	250	25	3500	0.4	25	2.63	5.37	1.9
TVR10181-M	180 \pm 10%	115	150	300	25	3500	0.4	31	2.8	4.8	1.6
TVR14820-M	82 \pm 10%	50	65	135	50	6000	0.6	28	2.96	5.34	1.6
TVR14101-M	100 \pm 10%	60	85	165	50	6000	0.6	35	2.98	5.35	1.7
TVR14121-M	120 \pm 10%	75	100	200	50	6000	0.6	42	3.0	5.36	1.8
TVR14151-M	150 \pm 10%	95	125	250	50	6000	0.6	53	3.03	5.37	1.9
TVR14181-M	180 \pm 10%	115	150	300	50	6000	0.6	67	2.8	4.8	1.6
TVR20820-M	82 \pm 10%	50	65	135	100	10000	1.0	56	3.36	5.74	1.8
TVR20101-M	100 \pm 10%	60	85	165	100	10000	1.0	70	3.38	5.75	1.9
TVR20121-M	120 \pm 10%	75	100	200	100	10000	1.0	85	3.4	5.76	2.0
TVR20151-M	150 \pm 10%	95	125	250	100	10000	1.0	106	3.43	5.77	2.1
TVR20181-M	180 \pm 10%	115	150	300	100	10000	1.0	127	3.2	5.2	1.8

Metal Oxide Varistor: TVR-M Series

Dip Type Varistor for 48Vdc Architecture of Vehicle's Electrical Systems



Agency Approval

Certified Model No.	Agency				
					
	UL 1449A	UL1449 5 th & cUL	EN/IEC 61051-1, IEC 61051-2, IEC 61051-2-2	IEC 60950-1 Annex Q IEC 62368-1 Annex G.8.1 IEC 62368-1 Annex G.8.2	GB/T10193-1997 GB/T10194-1997
	E510434 Surge-protective Devices for Use in Electric Vehicles	E314979	J 50259116 J 50405420		TVR10-M CQC13001090356 CQC13001090357 TVR14-M CQC15001128796 CQC15001128834 TVR20-M CQC15001128792 CQC15001128793
TVR10820-M	√	√			√
TVR10101-M	√	√			√
TVR10121-M	√	√			√
TVR10151-M	√	√			√
TVR10181-M		√			√
TVR14820-M	√	√			√
TVR14101-M	√	√			√
TVR14121-M	√	√			√
TVR14151-M	√	√			√
TVR14181-M		√	√		√
TVR20820-M	√	√			√
TVR20101-M	√	√			√
TVR20121-M	√	√			√
TVR20151-M	√	√			√
TVR20181-M		√		√	√

Metal Oxide Varistor: TVR-M Series

Dip Type Varistor for 48Vdc Architecture of Vehicle's Electrical Systems



■ Power Derating Curve

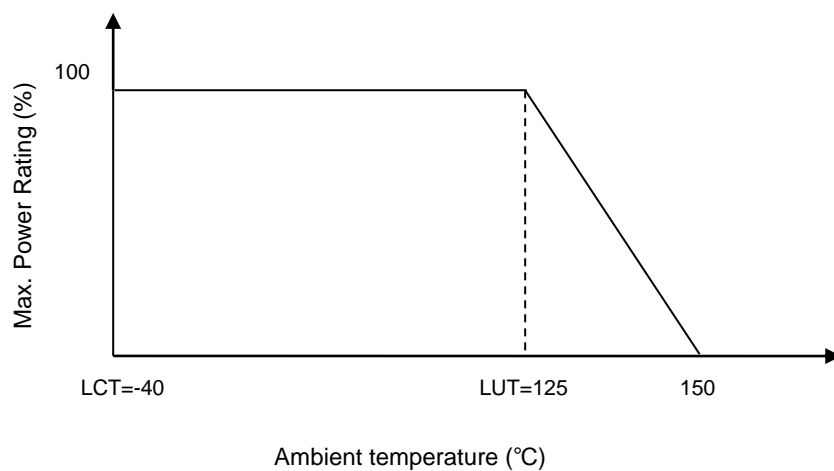

■ Surge Current Standard Waveform

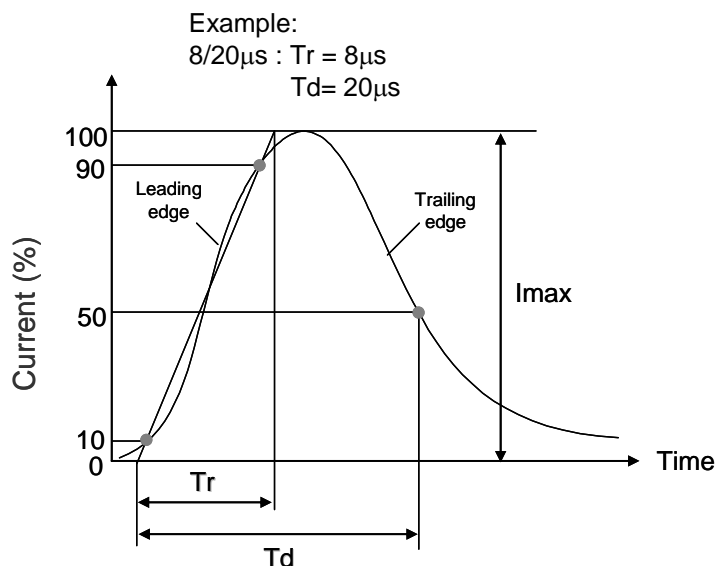

Metal Oxide Varistor: TVR-M Series

Dip Type Varistor for 48Vdc Architecture of Vehicle's Electrical Systems



■ Max. Surge Current Derating Curves

TVR10820-M to TVR10181-M

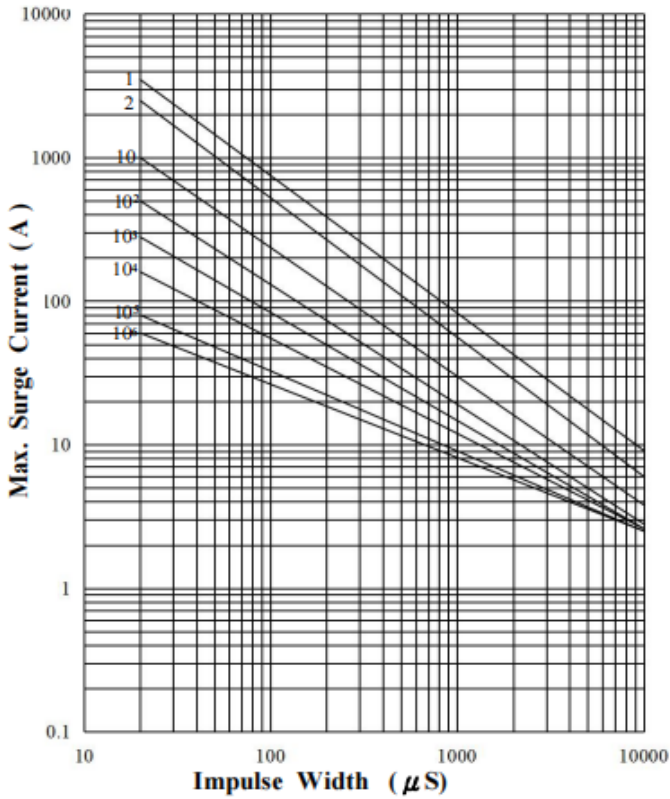

TVR14820-M to TVR14181-M

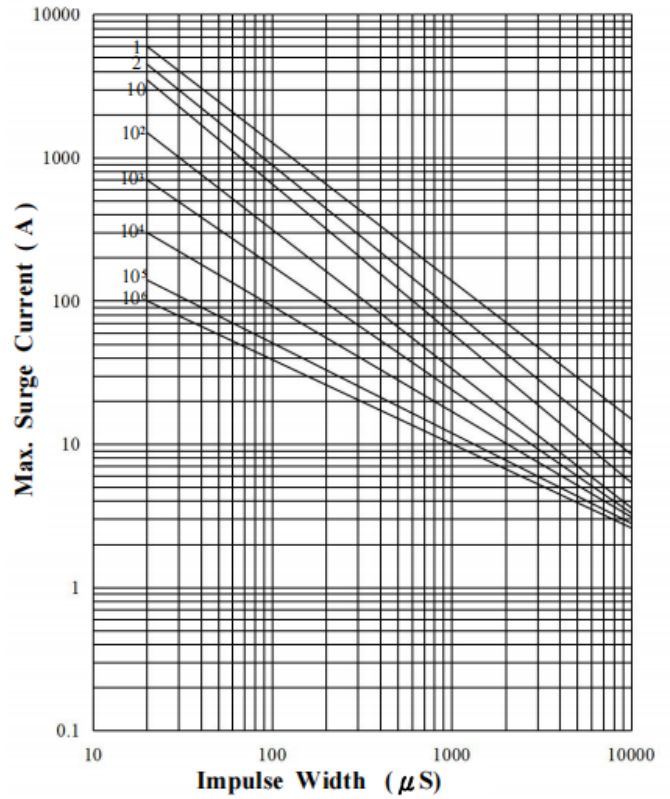

TVR20820-M to TVR20181-M

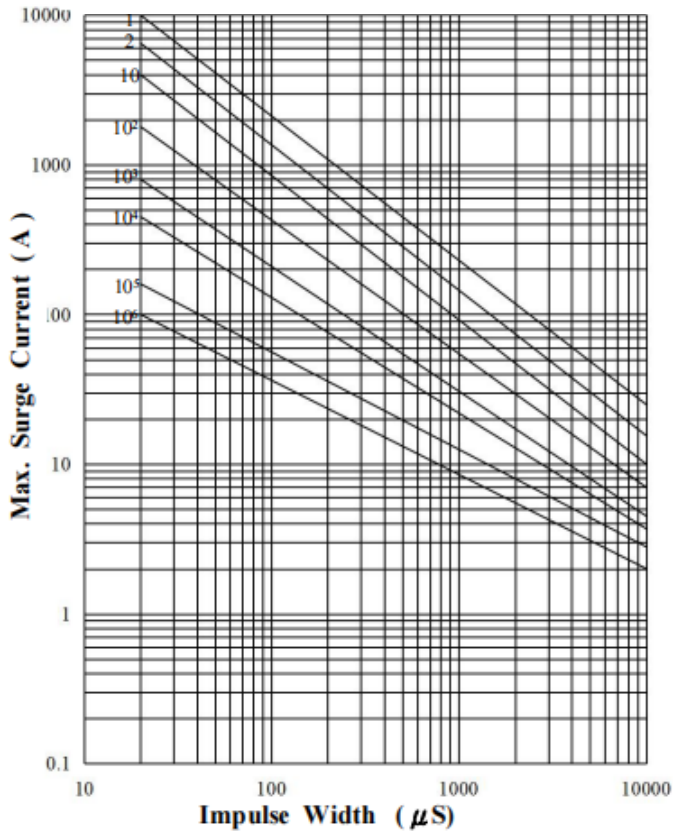

Metal Oxide Varistor: TVR-M Series

Dip Type Varistor for 48Vdc Architecture of Vehicle's Electrical Systems



■ Max. Leakage Current and Max. Clamping Voltage Curves

Max. Leakage Current and Max. Clamping Voltage Curves (TVR10820M to TVR10181M)

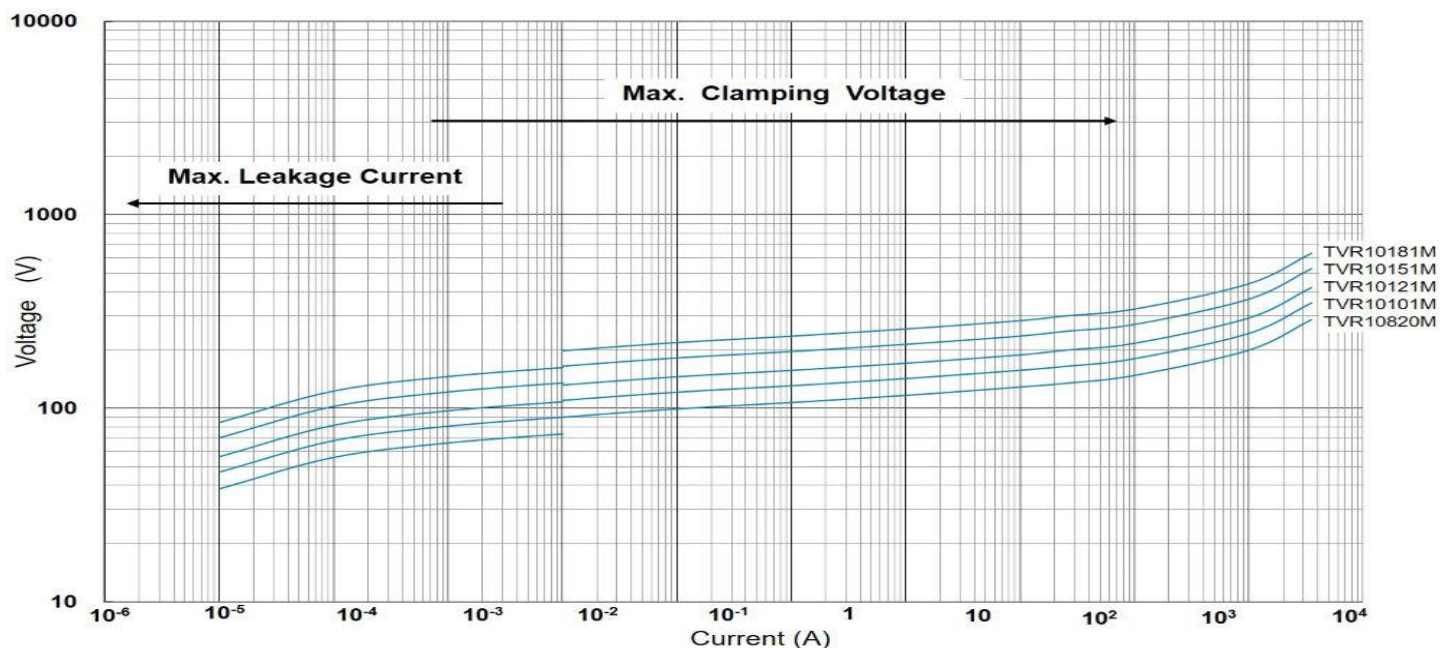

Max. Leakage Current and Max. Clamping Voltage Curves (TVR14820M to TVR14181M)

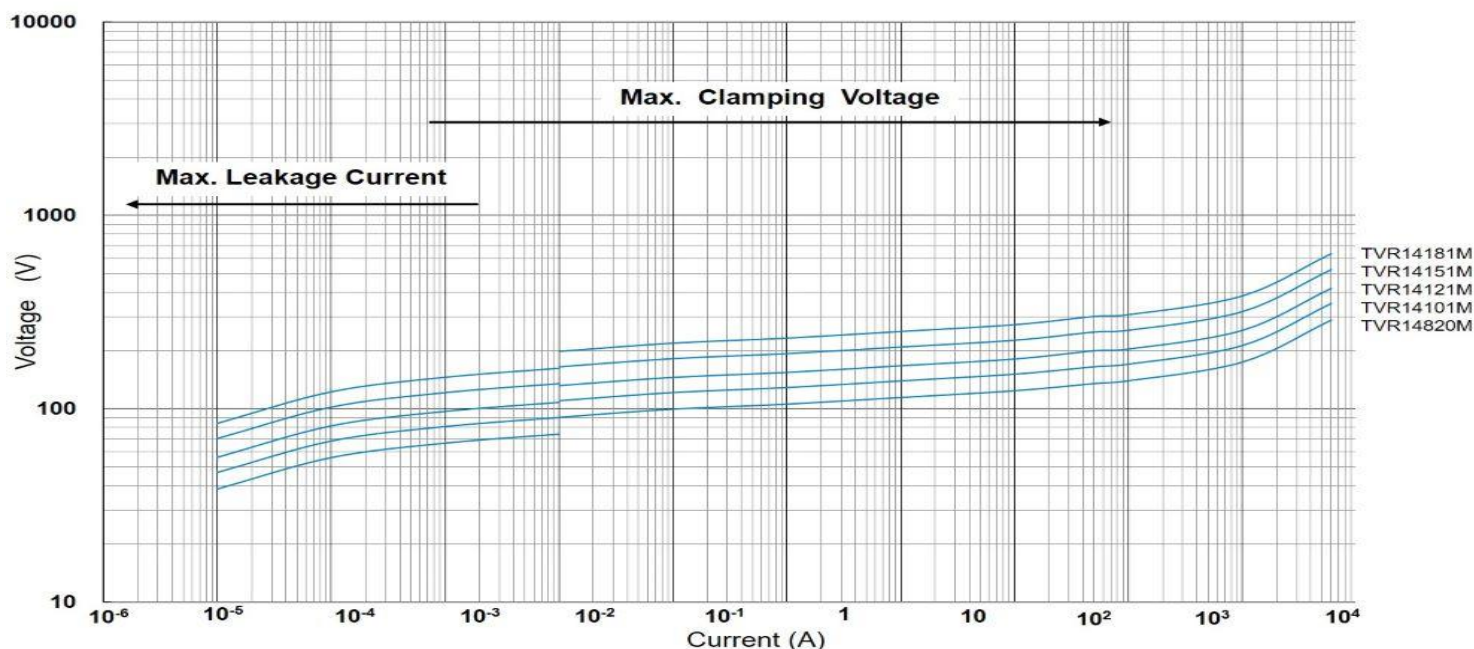

Metal Oxide Varistor: TVR-M Series

Dip Type Varistor for 48Vdc Architecture of Vehicle's Electrical Systems



Max. Leakage Current and Max. Clamping Voltage Curves

Max. Leakage Current and Max. Clamping Voltage Curves (TVR20820M to TVR20181M)

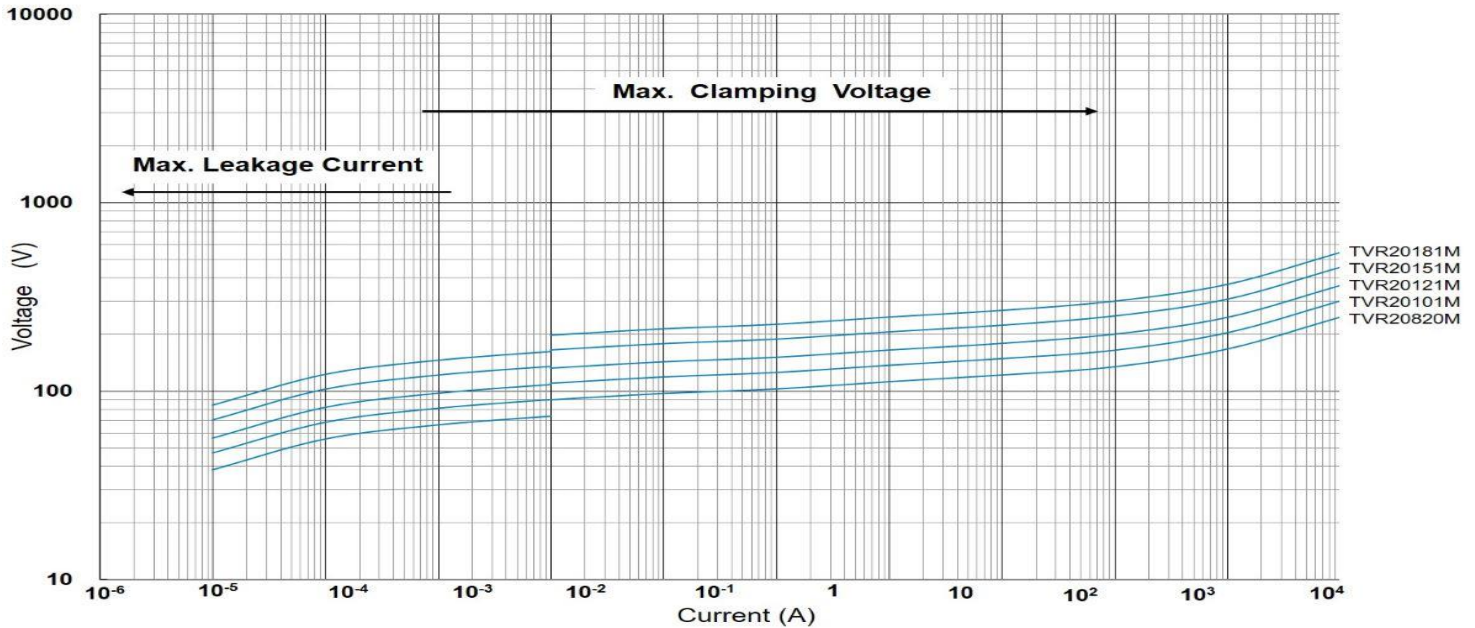

Soldering Recommendation

IR-reflow Soldering Profile

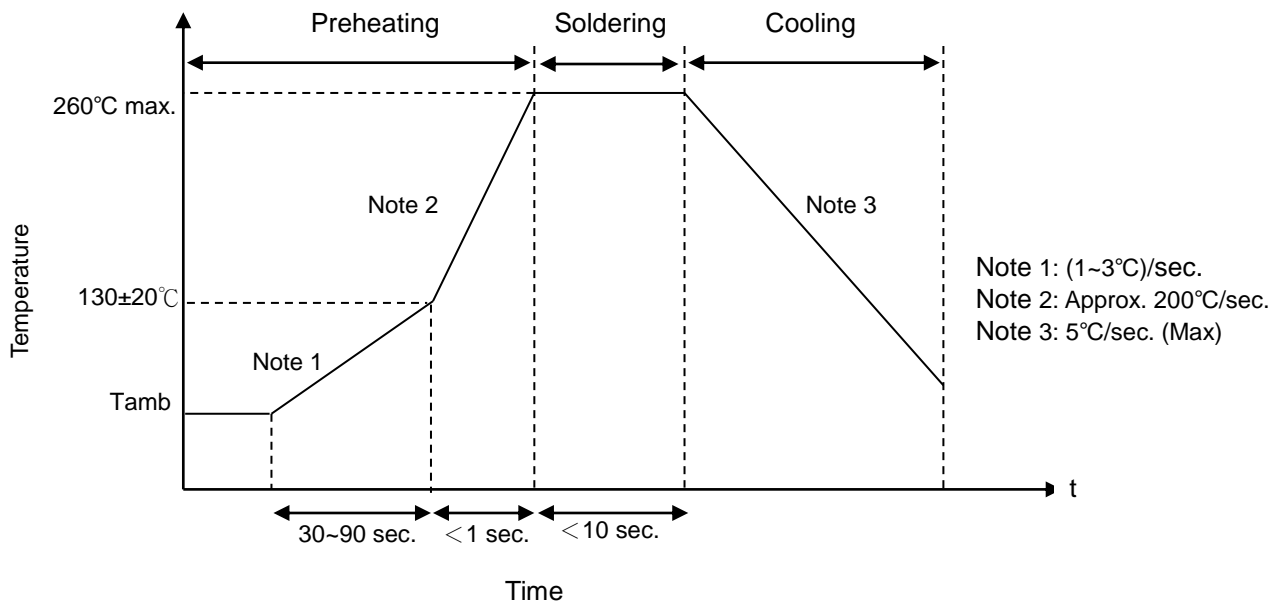

Recommended Reworking Conditions with Soldering Iron

Item	Conditions
Temperature of Soldering Iron-tip	360°C (max.)
Soldering Time	3 sec (max.)
Diameter of Soldering Iron-tip	2 mm (min.)

Metal Oxide Varistor: TVR-M Series

Dip Type Varistor for 48Vdc Architecture of Vehicle's Electrical Systems



■ Reliability (based on AEC-Q200 Rev-D)

Item	Standard	Test conditions / Methods	Specifications
Varistor Voltage	Specification Standard	The voltage between two terminals with the specified measuring current applied is called varistor voltage.	To meet the specified value
Clamping Voltage	Specification Standard	The maximum voltage between two terminals with the specified standard impulse current (8/20 μ s) applied	To meet the specified value
High Temperature Exposure (Storage)	MIL-STD-202 Method 108	Test temp.: 150 +3/-0°C Duration: 1000 h Unpowered Measurement at 24 \pm 2 hours after test conclusion.	No visible damage $\Delta V_{1mA}/V_{1mA}$ $\leq 10\%$ $\Delta V_{clamp}/V_{clamp}$ $\leq 10\%$
Resistance to Soldering Heat	MIL-STD-202 Method 210	No pre-heat of samples. Temperature: 260 \pm 5°C, Time: 10 \pm 1 s Immersion and emersion rate 25mm/s \pm 6 mm/s Number of heat cycles: 1	No visible damage $\Delta V_{1mA}/V_{1mA}$ $\leq 10\%$ $\Delta V_{clamp}/V_{clamp}$ $\leq 10\%$
Vibration	MIL-STD-202 Method 204	Acceleration: 5 g's Sweep time: 20 min Frequency range: 10 to 2000 Hz 3 \times 12 cycles	No visible damage $\Delta V_{1mA}/V_{1mA}$ $\leq 10\%$ $\Delta V_{clamp}/V_{clamp}$ $\leq 10\%$
Solderability	J-STD-002	245 \pm 5°C, 5 +0/-0.5sec	At least 95% of terminal electrode is covered by new solder
Terminal Strength	MIL-STD-202 Method 211	1. Pull test (2.27 kg) 2. Wire-lead bend test (227 g) Duration of the applied forces: 10 \pm 1sec	No visible damage $\Delta V_{1mA}/V_{1mA}$ $\leq 10\%$ $\Delta V_{clamp}/V_{clamp}$ $\leq 10\%$
Biased Humidity	MIL-STD-202 Method 103	Test temp.: 85°C Rel. humidity of air: 85% Duration: 1000 h Test Power Bias at 85%(+5%/-0%)of rated varistor voltage Measurement at 24 \pm 2 hours after test conclusion	No visible damage $\Delta V_{1mA}/V_{1mA}$ $\leq 10\%$ $\Delta V_{clamp}/V_{clamp}$ $\leq 10\%$
Operational Life	MIL-STD-202 Method 108	Test temp.: 125 +3/-0°C Duration: 1000 h Test Power: Bias at 85% (+5%/-0%) of rated varistor voltage	No visible damage $\Delta V_{1mA}/V_{1mA}$ $\leq 10\%$ $\Delta V_{clamp}/V_{clamp}$ $\leq 10\%$
Temperature Cycling	JESD22 Method JA-104	Lower test temp. : -40 +0/-10°C Upper test temp. : 125 +15/-0°C Soak time at lower or upper temp. : 15 min Transfer time: 5 mins Cycle time: 2 Cycles/hr Number of cycles: 1000 Measurement at 24 \pm 2 hours after test conclusion.	No visible damage $\Delta V_{1mA}/V_{1mA}$ $\leq 10\%$ $\Delta V_{clamp}/V_{clamp}$ $\leq 10\%$
Mechanical Shock	MIL-STD-202, Method 213	Peak value 100g's half sine waveform Normal duration (D): 6ms In 3 directions perpendicularly intersecting each other (total 18 times)	No visible damage $\Delta V_{1mA}/V_{1mA}$ $\leq 10\%$ $\Delta V_{clamp}/V_{clamp}$ $\leq 10\%$
Resistance to solvents	MIL-STD-202 Method 215	Add aqueous wash chemical- OKEM Clean or equivalent. Do not use banned solvents	No visible damage
8/20 μ S Surge Current Derating	IEC 61051-1	8/20 μ s waveform, 10 surge currents, unipolar, interval 30 secs	$\Delta V_{1mA}/V_{1mA}$ $\leq 10\%$ No visible damage

Metal Oxide Varistor: TVR-M Series

Dip Type Varistor for 48Vdc Architecture of Vehicle's Electrical Systems



Package

Taping Specification

L Type (Straight Lead)

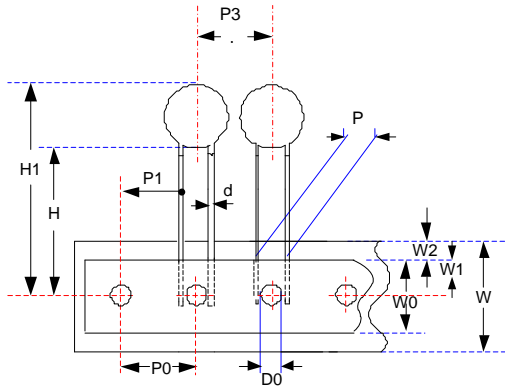

Figure A

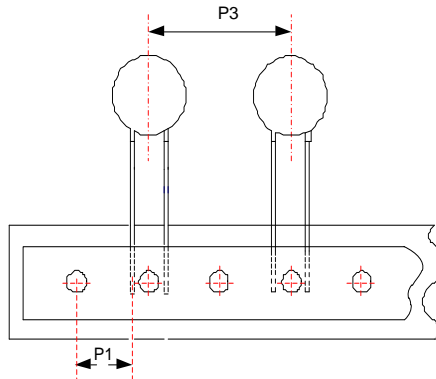

Figure B

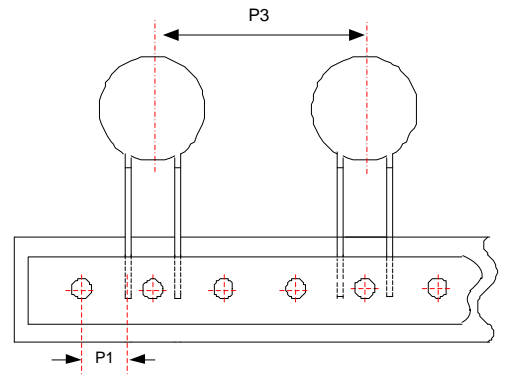

Figure C

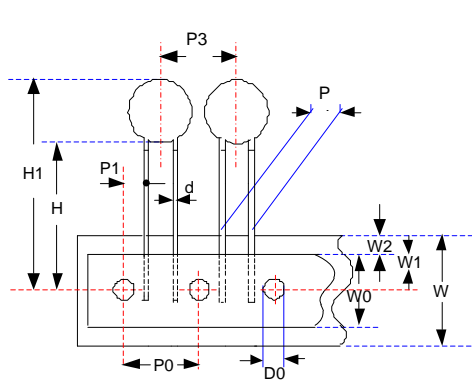

Figure D

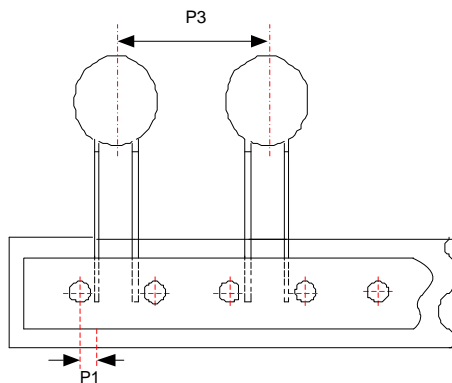
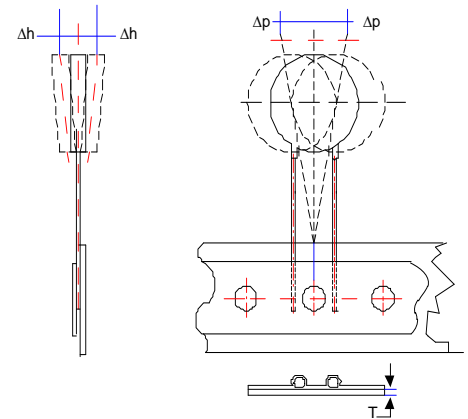

Figure E



(Unit: mm)

Taping Code	Body Size	P ₀	P	P ₃	P ₁	H	H ₁	d	W ₀	W ₁	W ₂	W	ΔP	Δh	D ₀	T	Figure
		±0.3	±1	±1	±1	+2/-0	Max.	±0.02	±1	+0.75/-0.5	Max	+1/-0.5	Max.	Max.	±0.2	±0.2	
A (P ₀ :12.7)	10-M	12.7	7.5	12.7	8.55	18	33.5	0.8	12	9	3	18	1	2	4	0.6	A
	14-M	12.7	7.5	25.4	8.55	18	38	0.8	12	9	3	18	1	2	4	0.6	B
	20-M	12.7	10.0	25.4	7.20	18	40.5	1.0	12	9	3	18	1	2	4	0.6	C
E (P ₀ :15.0)	10-M	15	7.5	15.0	3.35	18	33.5	0.8	12	9	3	18	1	2	4	0.6	D
	14-M	15	7.5	30.0	3.35	18	38	0.8	12	9	3	18	1	2	4	0.6	E
	20-M	15	10.0	30.0	9.50	18	40.5	1.0	12	9	3	18	1	2	4	0.6	B

Metal Oxide Varistor: TVR-M Series

Dip Type Varistor for 48Vdc Architecture of Vehicle's Electrical Systems



Quantity

Bulk Packing

Series	Quantity of Straight Lead Type (pcs/bag)	Quantity of Cut Lead Type (pcs/bag)	Quantity of Kink Lead Type (pcs/bag)
TVR10(820-181)-M	200	200	200
TVR14(820-181)-M	100	100	100
TVR20(820-181)-M	Box Packing: 640	50	50

Reel Packing

First Reel Packing

Series	A (mm)	Quantity (pcs/reel)
TVR10(820~181)-M	55	750
TVR14(820~181)-M		750
TVR20(820~181)-M		500

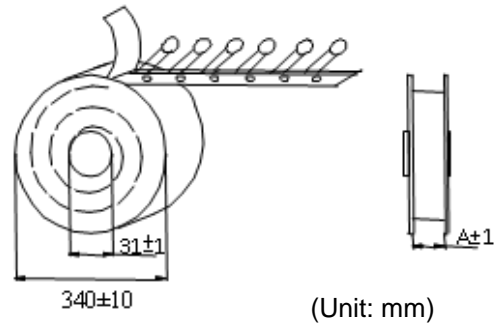

Second Reel Packing

Series	A (mm)	Quantity (pcs/reel) P0=12.7mm	Quantity (pcs/reel) P0=15mm
TVR10(820~181)-M	46	1,000	1,000
TVR14(820~181)-M	46	750	750
TVR20(820~181)-M	55	500	500

Ammo Packing

Series	Quantity (pcs/box) P0=12.7mm	Quantity (pcs/box) P0=15.0mm
TVR10(820~181)-M	900	800
TVR14(820~181)-M	500	450
TVR20(820~181)-M	350	300

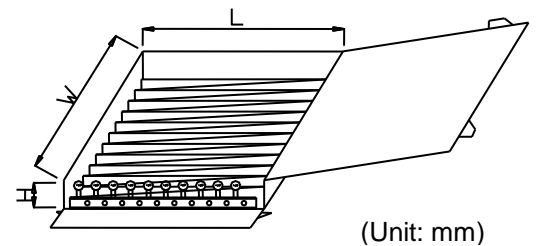

Series	W±5	L±5	H±5
TVR05 ~ TVR20-M	345	275	55

Metal Oxide Varistor: TVR-M Series

Dip Type Varistor for 48Vdc Architecture of Vehicle's Electrical Systems



■ Warehouse Storage Conditions of Products

- Storage Conditions:
 1. Storage Temperature: $-10^{\circ}\text{C} \sim +40^{\circ}\text{C}$
 2. Relative Humidity: $\leq 75\%RH$
 3. Thermistors must be kept away from sunlight and stored in a non-corrosive atmosphere.
- Period of Storage: 1 year