

Features

- 1800Watts peak pulse power ($t_p = 8/20\mu s$)
- SOIC-8 Package
- Protects two lines in common and differential mode
- Solid-state silicon-avalanche technology
- Low clamping voltage
- Low leakage current
- Low capacitance
- Transient protection for high-speed data lines to
Bellcore 1089 (Intra-Building) 100A (2/10 μs)
ITU K.20 $I_{pp}=40A$ (5/310 μs)
IEC 61000-4-2 (ESD) $\pm 30kV$ (air), $\pm 30kV$ (contact)
IEC 61000-4-4 (EFT) 40A (5/50ns)
IEC 61000-4-5 (Lightning) 100A (8/20 μs)

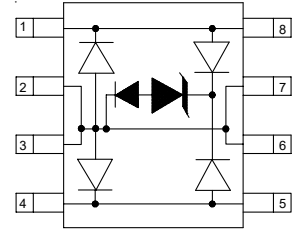

Mechanical Data

- **Case:** SOIC-8 (plastic package).
Lead free; RoHS compliant; Halogen free
- **Molding Compound Flammability Rating:**
UL 94 V-0
- **Terminals:** High temperature soldering guaranteed:
260 °C/10 sec. at terminals

Applications

- Low Voltage Interfaces
- T3/E3
- 10/100 Ethernet
- Set-Top Box
- ISDN Interfaces

Absolute Maximum Ratings

Ratings at 25 °C, ambient temperature unless otherwise specified

Parameter	Symbol	Value	Unit
Peak Pulse Power ($T_P=8/20\mu s$)	P_{PP}	1800	W
ESD contact/air discharge (IEC-61000-4-2)	V_{ESD}	30/30	kV
Peak Pulse Current ($T_P = 8/20\mu s$)	I_{PP}	100	A
Junction Temperature	T_J	-55 to +125	°C
Storage temperature	T_{STG}	-55 to +150	°C

Electrical Characteristics

($T_A = 25$ °C unless otherwise specified)

Parameter	Symbol	Condition	Min	Typ	Max	Unit
Reverse stand-off Voltage	V_{RWM}				3.3	V
Reverse Breakdown Voltage	V_{BR}	$I_T=1mA$	3.7			V
Reverse Leakage Current	I_R	$V_R=3.3V$			0.5	μA
Clamping Voltage (IO to GND)	V_C	$I_{PP}=100A, T_P=8/20\mu S$		16	20	V
Clamping Voltage (IO to IO)	V_C	$I_{PP}=100A, T_P=8/20\mu S$		20	23	V
Junction Capacitance	C_J	$V_R=0V, f=1MHz, I/O$ to I/O		5.0	8.0	pF
	C_J	$V_R=0V, f=1MHz, I/O$ to GND		10	15	pF

Typical Characteristics ($T_{amb} = 25\text{ }^{\circ}\text{C}$ unless otherwise specified)

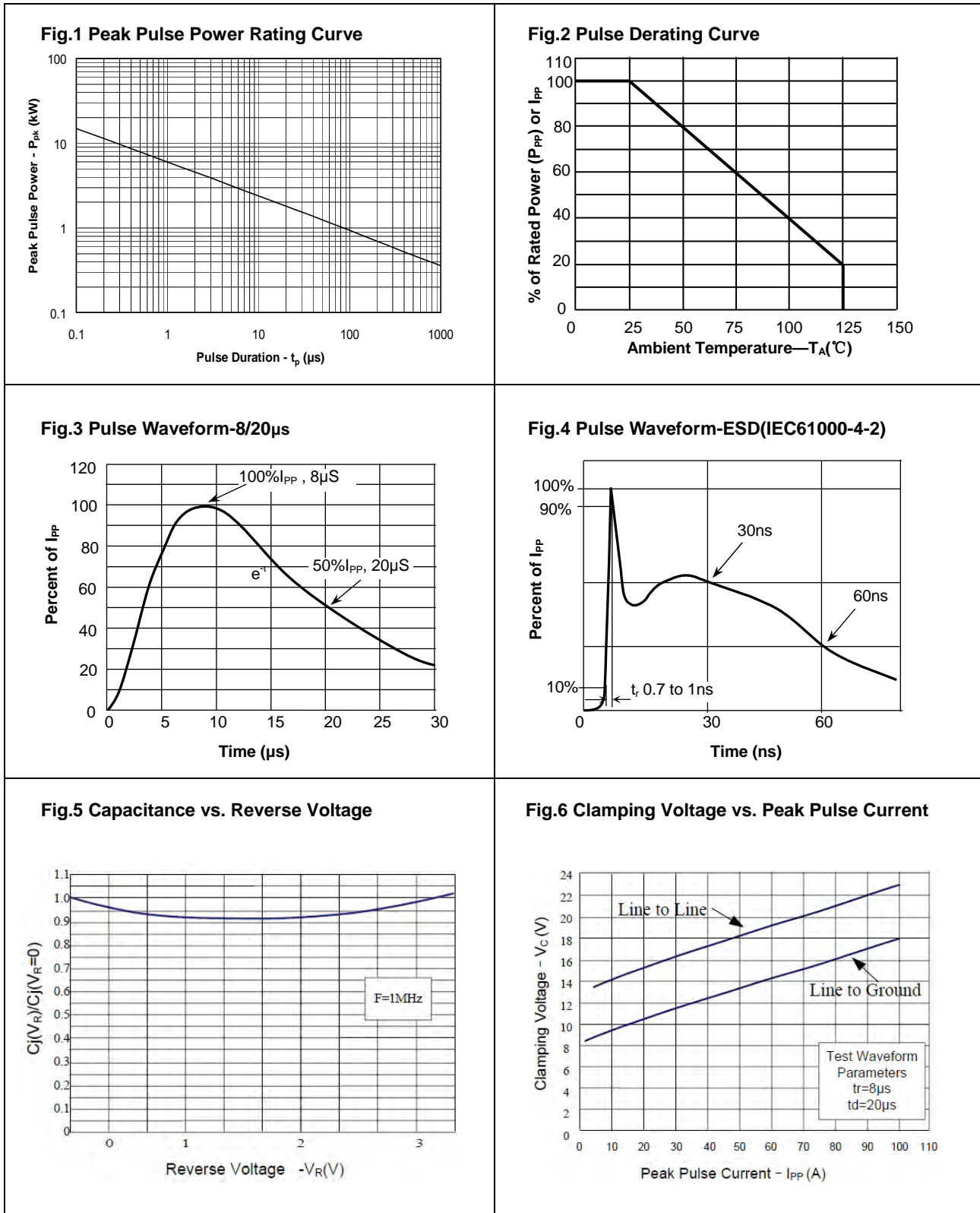

Package Dimensions

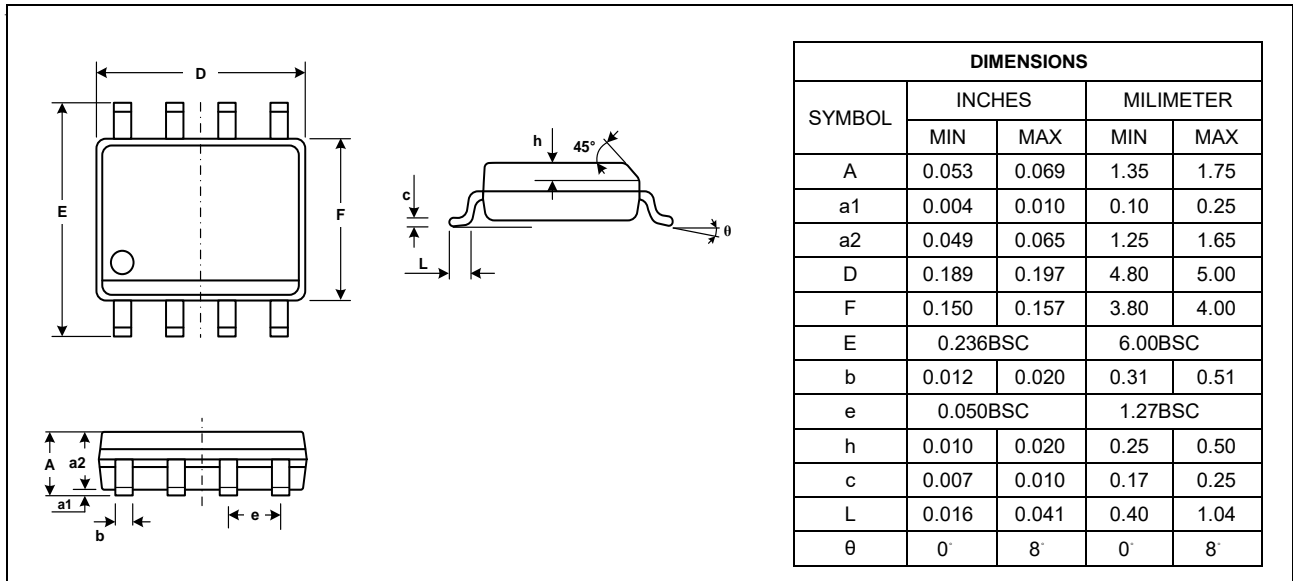

Pad Dimensions

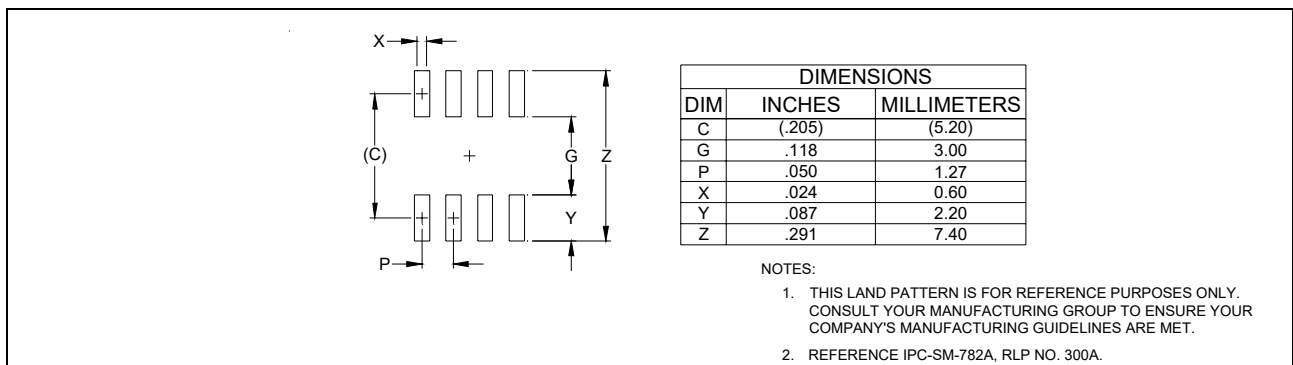

Marking

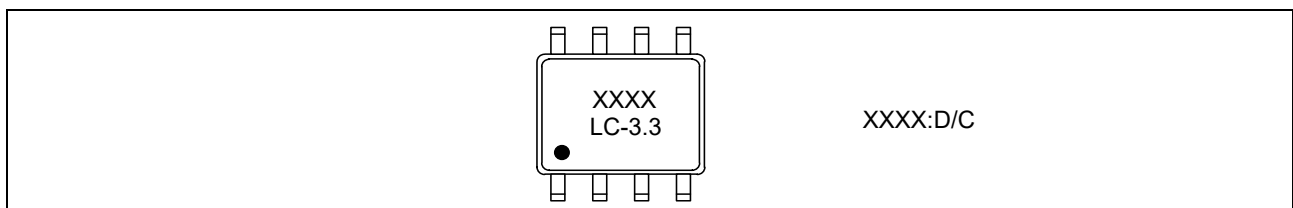

Ordering information

Order code	Package	Packaging option	Base quantity	Packaging specification
YEDSOP83R100V	SOIC-8	Tape and reel	2500pcs / reel	EIA STD RS-481