

### Features

- 1500Watts peak pulse power ( $t_p = 8/20\mu s$ )
- SOT-23-6 Package
- Solid-state silicon-avalanche technology
- Low clamping voltage
- Low leakage current
- Low capacitance (1.2pF typical Line to Line)
- ESD Protection one data/power lines to:  
IEC 61000-4-2  $\pm 30KV$  contact  $\pm 30KV$  air  
IEC 61000-4-4 (EFT) 40A (5/50ns)  
IEC 61000-4-5 (Lightning) 50A (8/20 $\mu s$ )

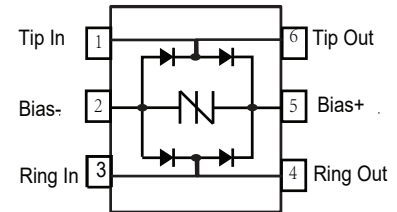

### Mechanical Data

- **Case:** SOT-23-6 (plastic package).  
Lead free; RoHS compliant; Halogen free
- **Molding Compound Flammability Rating:**  
UL 94 V-0
- **Terminals:** High temperature soldering guaranteed:  
260 °C/10 sec. at terminals

### Applications

- ADSL,ADSL2+
- VDSL2,VDSL2+
- G.fast

### Absolute Maximum Ratings

Ratings at 25 °C, ambient temperature unless otherwise specified

Parameter	Symbol	Value	Unit
Peak Pulse Power ( $T_P=8/20\mu S$ )	$P_{PP}$	1500	W
ESD contact/air discharge (IEC-61000-4-2)	$V_{ESD}$	30/30	kV
Peak Pulse Current ( $T_P = 8/20\mu S$ )	$I_{PP}$	50	A
Junction Temperature	$T_J$	-55 to +125	°C
Storage temperature	$T_{STG}$	-55 to +150	°C

### Electrical Characteristics

( $T_A = 25$  °C unless otherwise specified)

Parameter	Symbol	Condition	Min	Typ	Max	Unit
Reverse stand-off Voltage	$V_{RWM}$				24	V
Holding Voltage	$V_H$	$I_T=I_H$		3.0		V
Holding Current	$I_H$		20			mA
Reverse Leakage Current	$I_R$	$V_{RWM}=24V$			0.5	uA
Clamping Voltage(ESD)	$V_C$	$I_{PP}=50A, T_P=8/20\mu S$		25		V
Trigger Voltage	$V_T$			31		V
Junction Capacitance	$C_J$	$V_R=0V, f=1MHz, I/O$ to $I/O$		1.2		pF

**Typical Characteristics** ( $T_{amb} = 25\text{ }^{\circ}\text{C}$  unless otherwise specified)

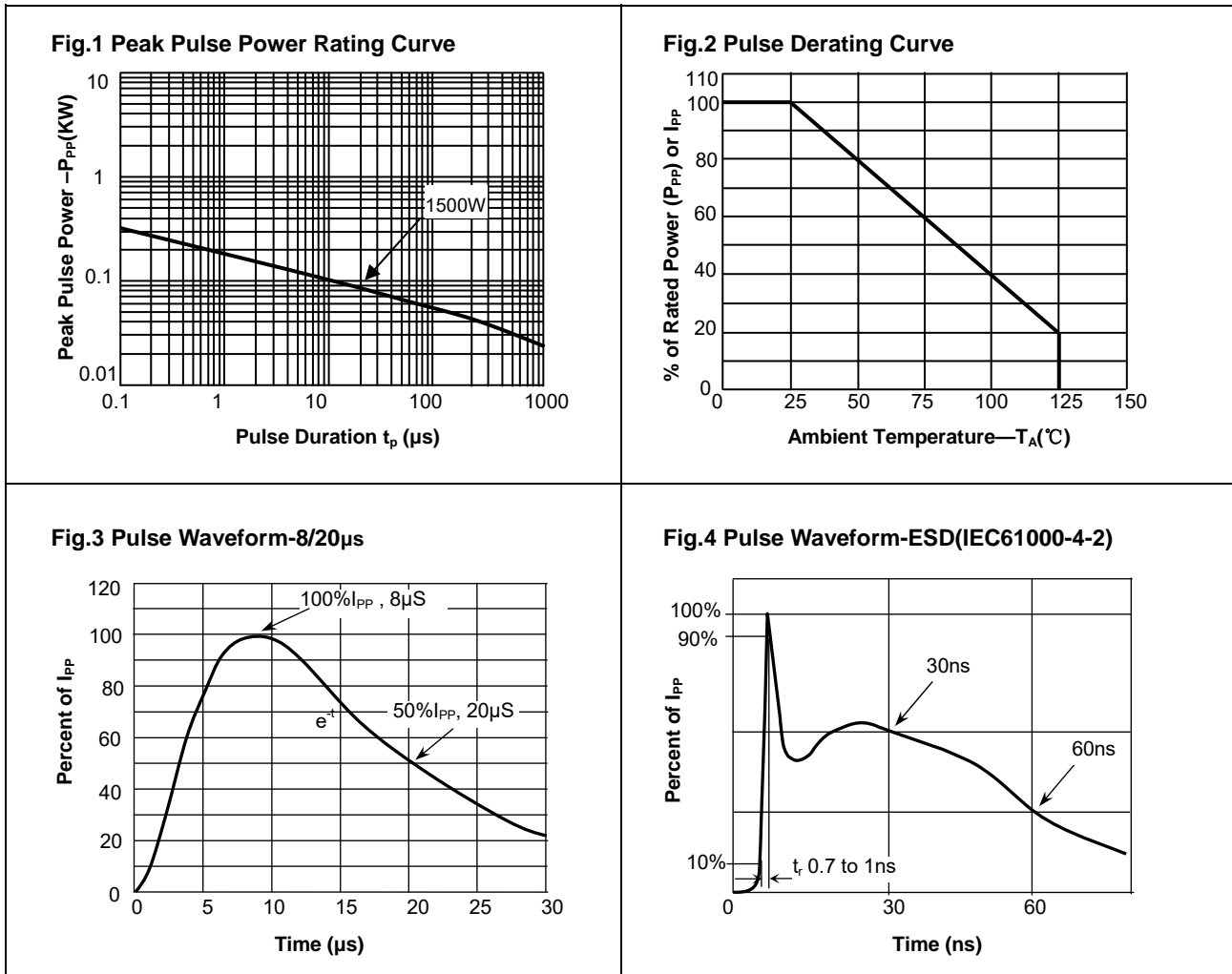

**Application**

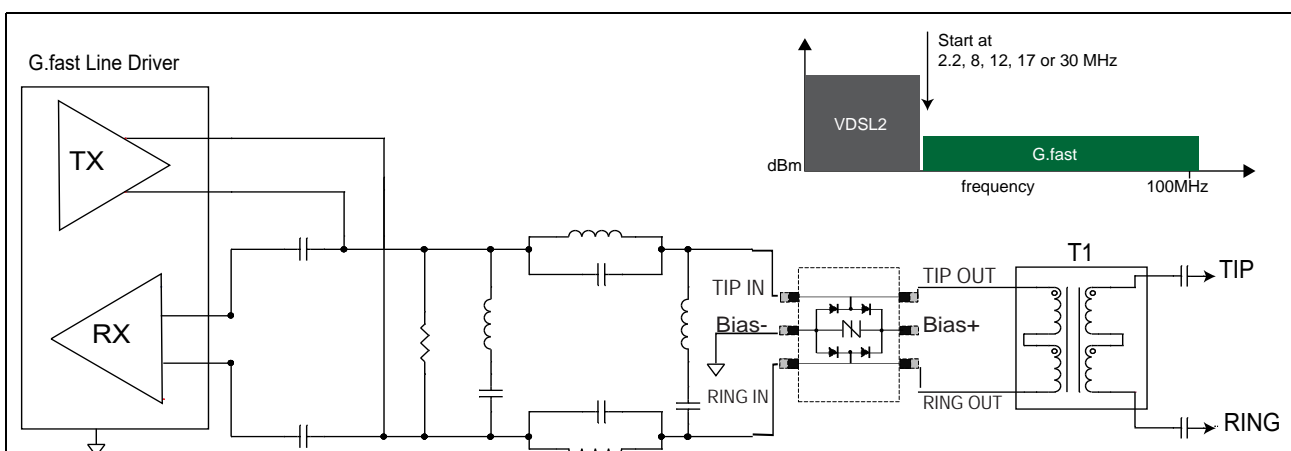
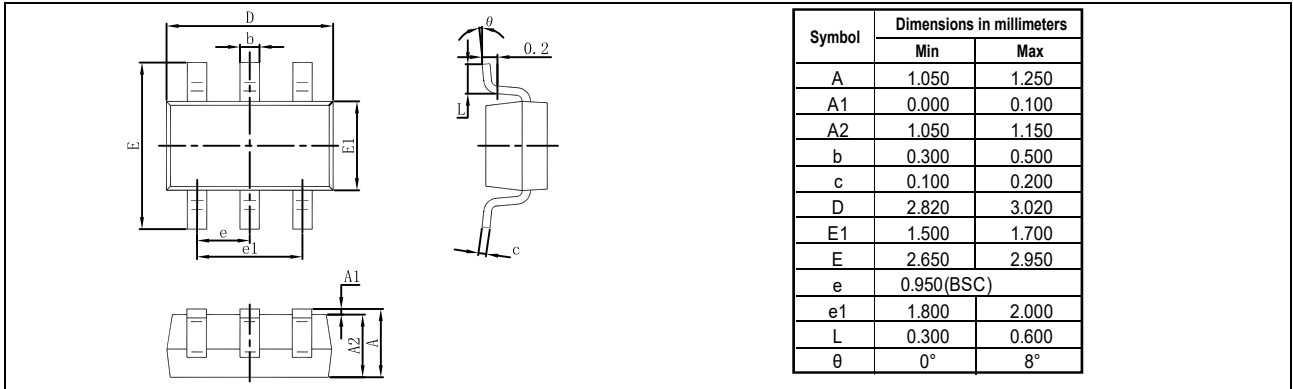

Fig.5 G.fast protection

The "Bias -" lead can be connected to the line driver ground with the "Bias +" lead left open so this solution provides both differential and common mode protection. Both "Bias -" and "Bias +" leads can be left floating for differential only protection and finally for capacitance variance sensitive applications, the "Bias -" and "Bias +" leads may have the appropriate polarity voltage (< VDRM) applied to further minimize any negative capacitance effects.

### Package Dimensions



### Pad dimensions

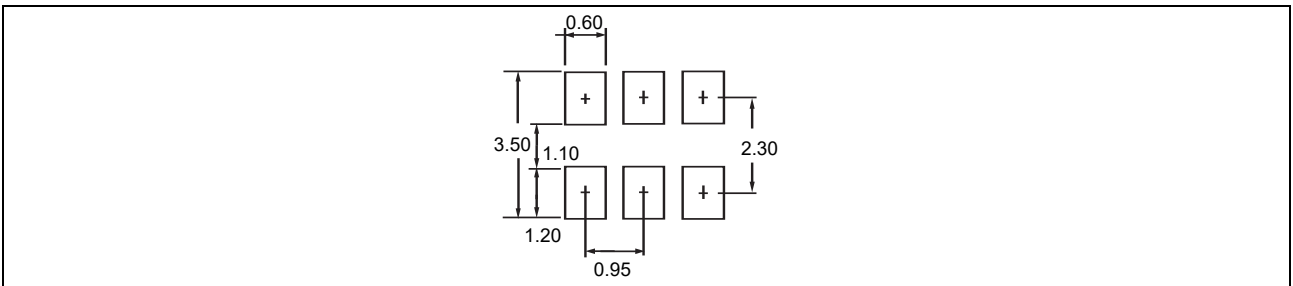

### Package information

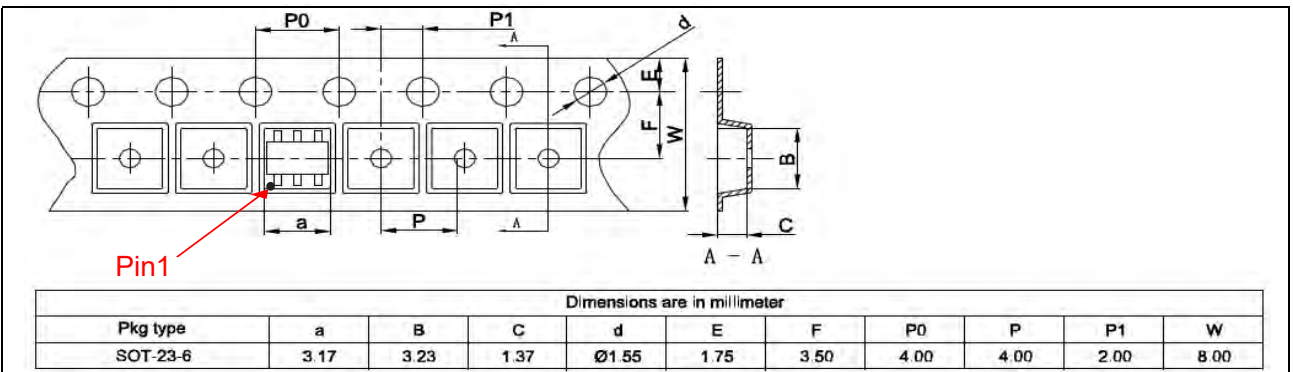

### Marking



### Ordering information

Order code	Package	Packaging option	Base quantity	Packaging specification
YELST262450AU	SOT-23-6	Tape and reel	3000pcs / reel	EIA STD RS-481