

EC (AC TO DC) FAN

80*80*25mm

RT8025 Series



RUNDA

www.szrunda.com

DIMENSIONS DRAWING



外框材质:环保防火PBT
 Frame:Thermoplastic PBT UL94-V0
 扇叶材质:环保防火PBT
 Imperller:Thermoplastic PBT UL94-V0
 轴承结构:双滚珠或长寿命含油结构
 Bearing system:2Ball or Long life sleeve
 单体风扇重量:54g
 Unit Weight:54g

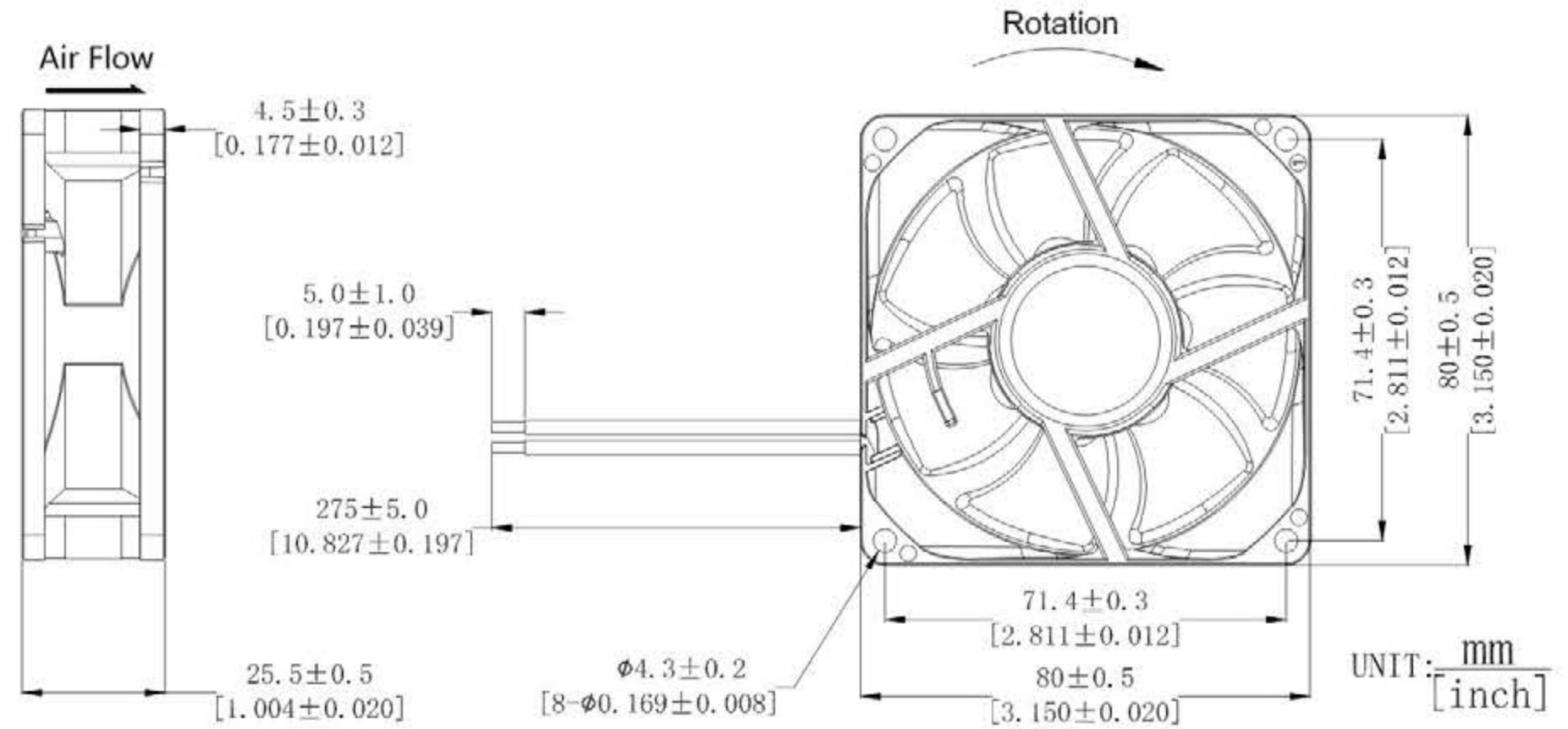

可选的功能参照列表 (Available Functions)

1.马达保护(Motor protection)

RP	SS	AS	CL
<input type="radio"/>	<input type="radio"/>	<input type="radio"/>	<input type="radio"/>

2.信号输出(Signal output)

FG	RD	RD	LD
<input type="radio"/>	<input type="radio"/>	<input type="radio"/>	<input type="radio"/>

3.调速方式(Speed control mode)

PWM	TP	VC	RC	CS
<input type="radio"/>	<input type="radio"/>	<input type="radio"/>	<input type="radio"/>	<input type="radio"/>

Fan Performance Curve

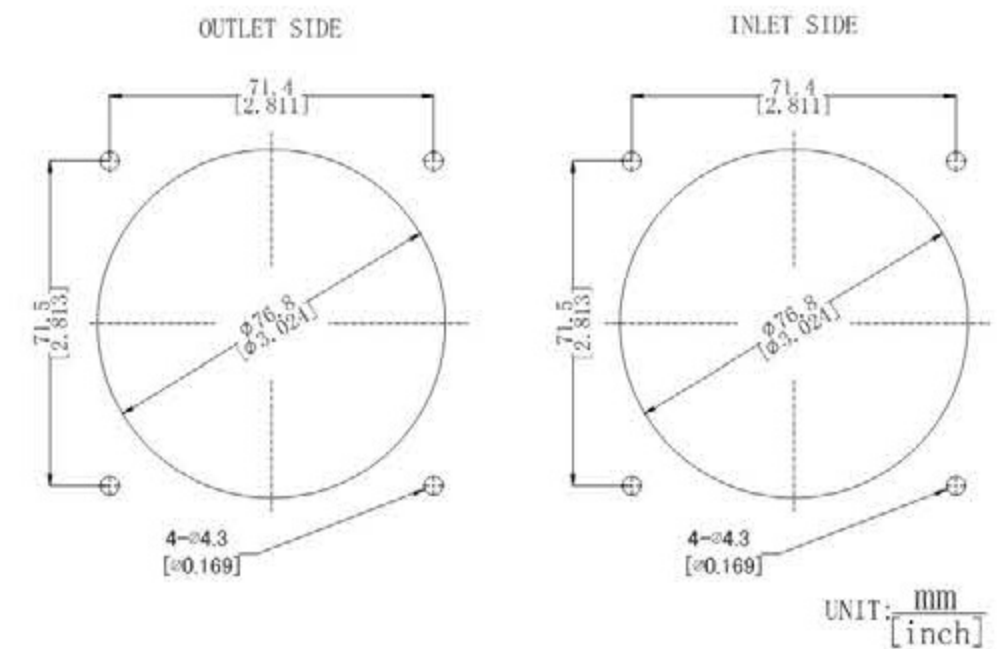
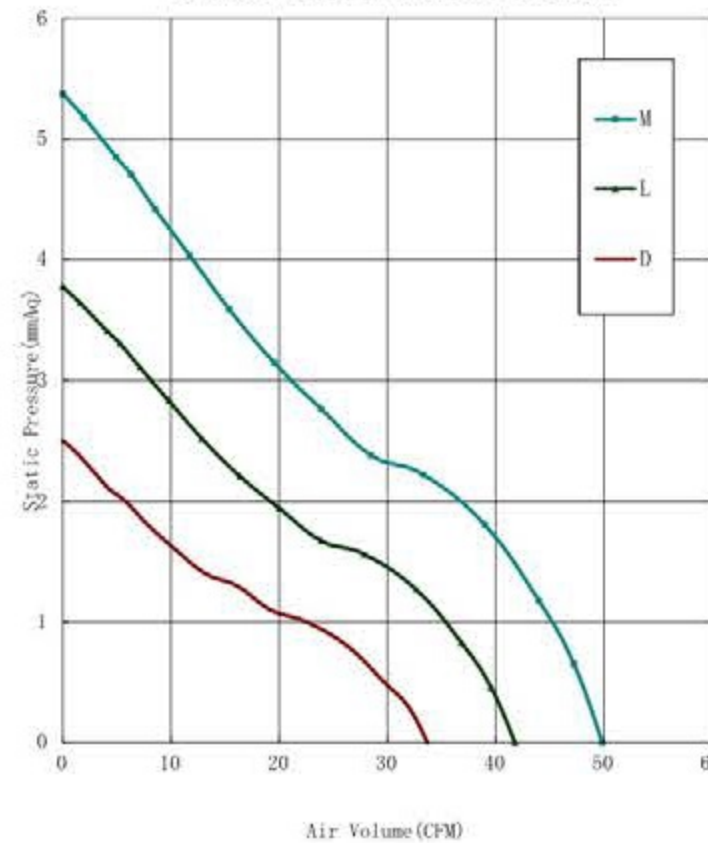

Part Number	Voltage(V)	Fre.(HZ)	Power(W)	Speed(RPM)	Air flow(Q)	Pressure(P)	Noise(dBA)
产品编号	电压范围	频率范围	功率	转速	(CFM) 风量	(Mmaq)风压	噪音
RT8025x11D	110(80~120)	45~65	3.0	2400	34.86	2.45	29.9
RT8025x11L		45~65	3.8	3000	43.23	3.77	34.8
RT8025x11M		45~65	4.2	3600	51.59	5.37	38.3
RT8025x22D	220(120~240)	45~65	3.0	2400	34.86	2.45	29.9
RT8025x22L		45~65	3.8	3000	43.23	3.77	34.8
RT8025x22M		45~65	4.2	3600	51.59	5.37	38.3

★ 如果您需要的转速或电压或功能不在这份清单上, 请与我们联系。
 If you want another rpm or voltage or functions which one is not in the list, please contact with our sales.

★ 提示1:功能的具体信息参照产品目录前页篇章。
 Notes1:The catalog have detail information in the front page for the functions.

★ 提示2:产品详细信息请参照承认书。
 Notes2:Product have a detail in the approval sheet.

★ 提示3:产品规格变更不另行通知。
 Notes3:Specifications are subject to change without notice.

★ 提示4:该款机型可制作相同转速的, 可在AC110V和AC220V双电压下使用。
 Note4:This model can be made in the same speed and used in AC110V, AC220V both.