

REV.	DESCRIPTION	DATE	DRAFTER	APPROVER
A1	DWG.REL	2020.05.18	DENG	JIN

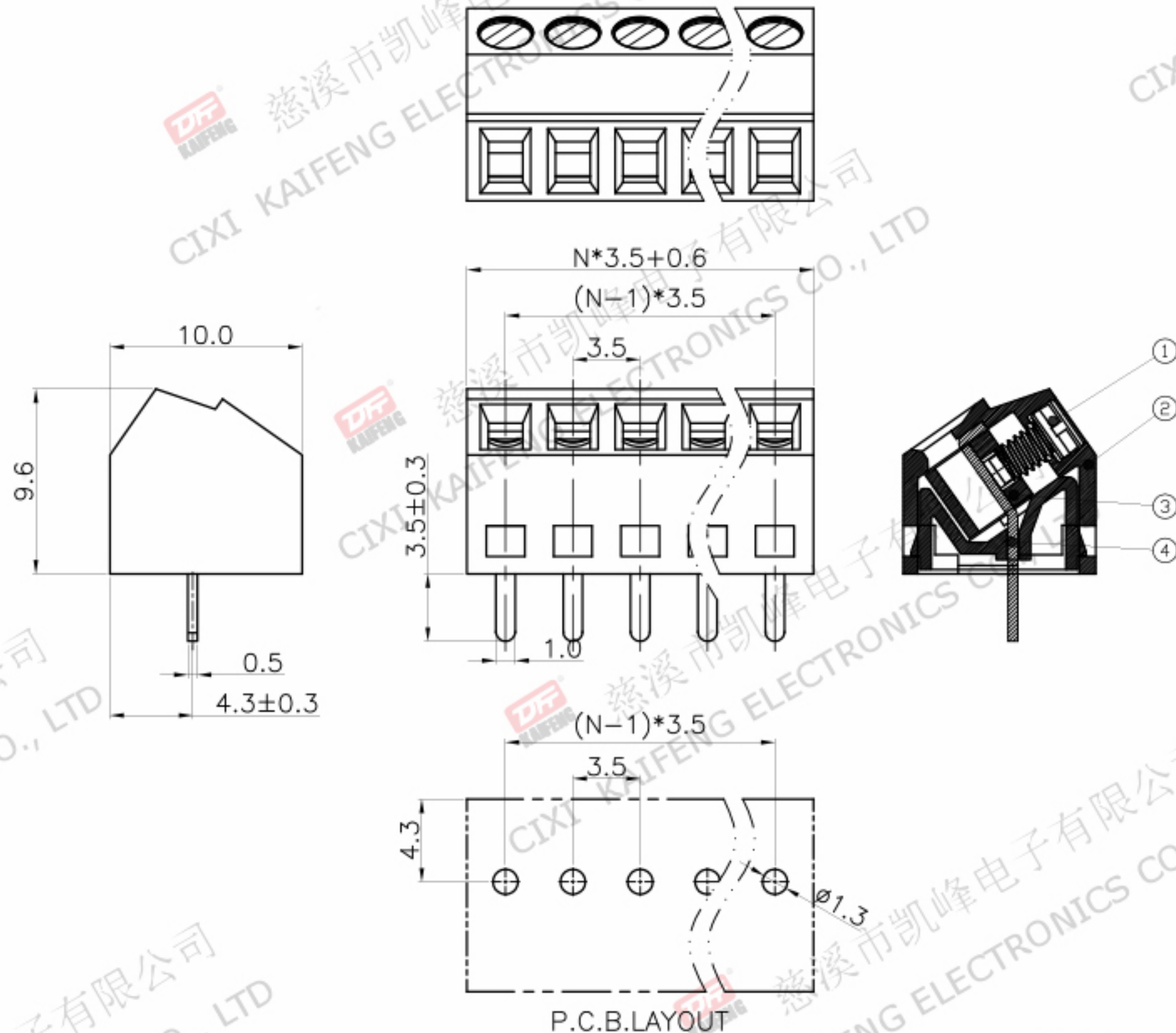

- Material
 - ① Screws : M2.0 steel, Zinc plated, *- slot type
 - ② Housing : PA66, UL94V-0
 - ③ Clamp : Copper alloy, Ni plated
 - ④ Pin header : Copper alloy, Tin plated
- Electrical

UL	IEC
Rated voltage : 300V	130V
Rated current : 10A	10A
Contact resistance : 20mΩ(Max)	
Insulation resistance: 500MΩ/DC500V	
Withstanding Voltage : AC1500V/1min	
Wire range: 24-16AWG 1.5mm ²	
- Mechanical
 - Operating temperature: -40°C ~ +105°C
 - Soldering temperature: 250°C ± 5/5sec
 - Torque: 0.2N.m (1.77Lb.in)
 - Strip length: 4-5mm
- RoHS compliance

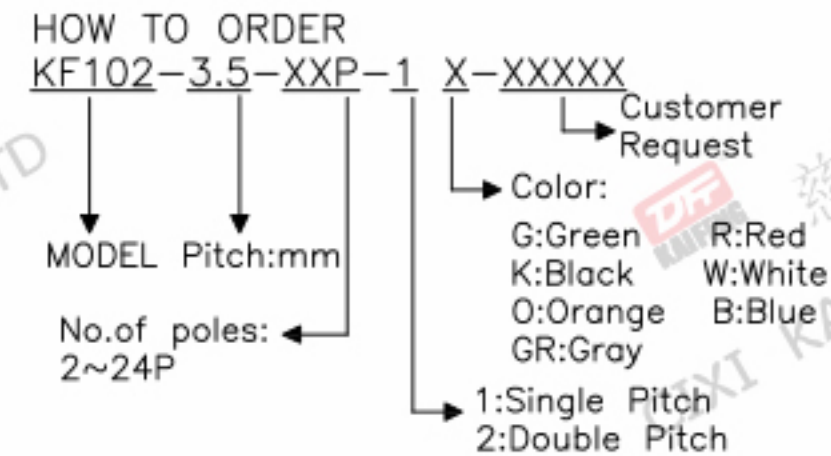

Pitch range	Nominal dimension range							PROJECTION	TITLE
>0	>6	>10	>0	>30	>60	>100	>150	UNIT	KF102-3.5-XXP-1X
~6	~10	~24	~30	~60	~100	~150	>150	SHEET SIZE	A4
±0.15	±0.20	±0.30	±0.30	±0.50	±0.70	±1.00	±1.30	SERIES	KF102
DRAWING TYPE		CUSTOMER DRAWING							
SCALE		1:1		SHEET		1 OF 1			
DRAWING NO.		W15000312							

DF 慈溪市凯峰电子有限公司
CIXI KAIFENG ELECTRONICS CO.,LTD

REV.	DESCRIPTION	DATE	DRAFTER	APPROVER
A1	DWG.REL	2020.05.18	DENG	JIN

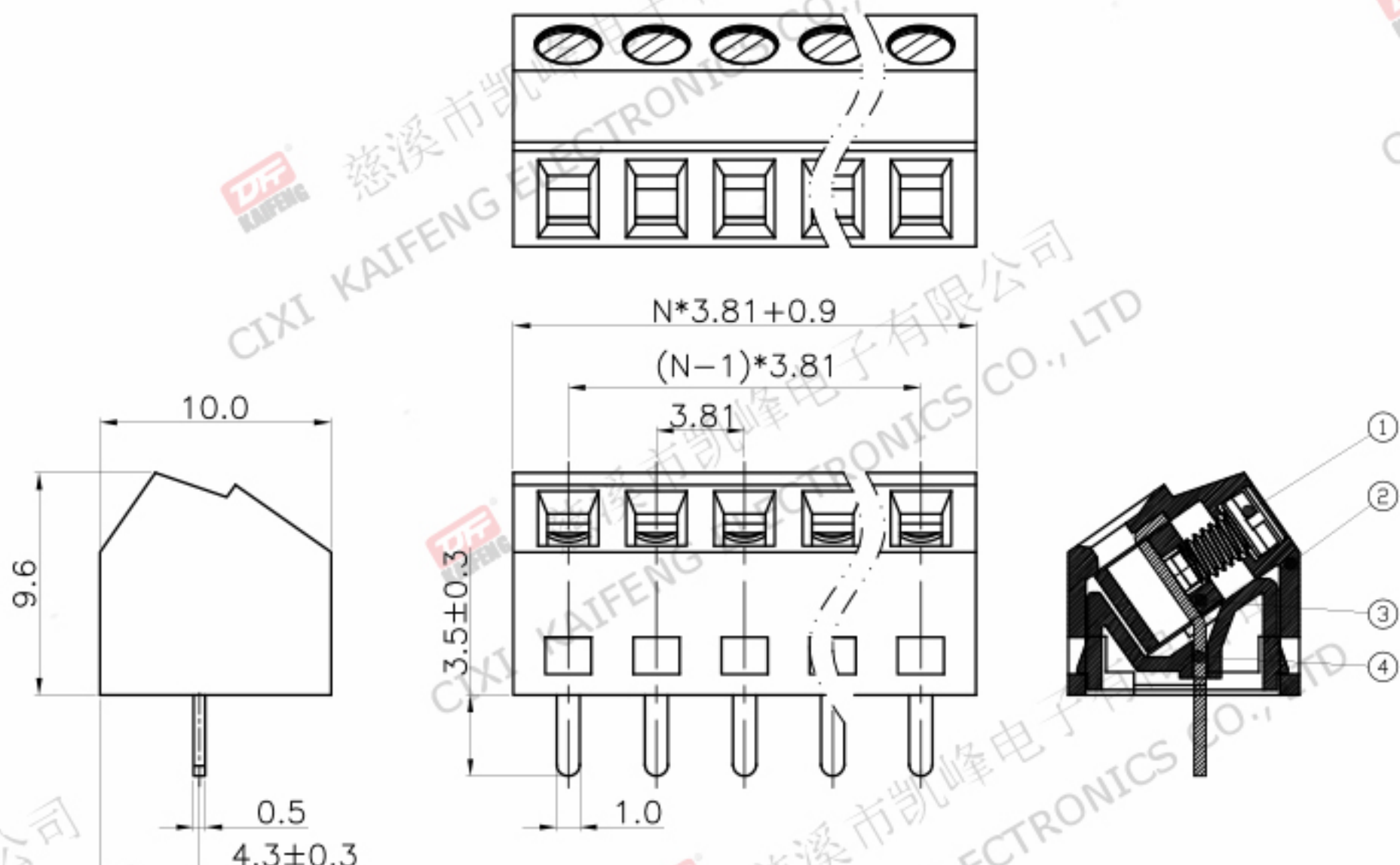

- Material
 - ØScrews : M2.0 steel, Zinc plated, *-*slot type
 - ØHousing : PA66, UL94V-0
 - ØClamp : Copper alloy, Ni plated
 - ØPin header : Copper alloy, Tin plated
- Electrical

	UL	IEC
Rated voltage :	300V	130V
Rated current :	10A	10A
Contact resistance :	20mΩ(Max)	
Insulation resistance:	500MΩ/DC500V	
Withstanding Voltage :	AC1500V/1min	
Wire range:	24-16AWG	1.5mm ²
- Mechanical
 - Operating temperature: -40°C ~ +105°C
 - Soldering temperature: 250°C ± 5 / 5sec
 - Torque: 0.2N.m (1.77Lb.in)
 - Strip length: 4-5mm
- RoHS compliance

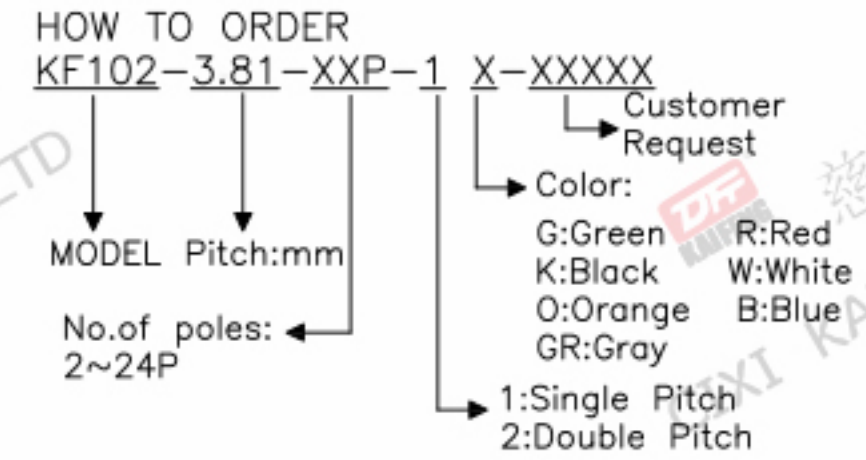
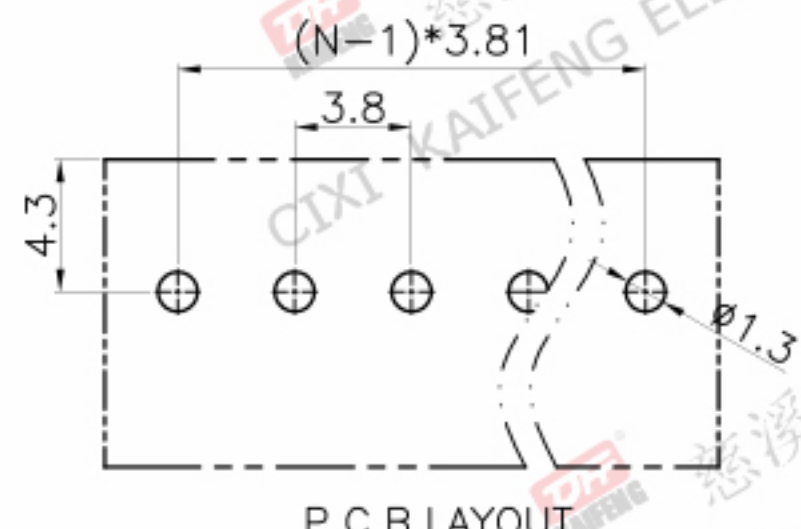

Pitch range	Nominal dimension range							PROJECTION	TITLE
>0	>6	>10	>0	>30	>60	>100	>150	UNIT	KF102-3.81-XXP
~6	~10	~24	~30	~60	~100	~150	>150	SHEET SIZE	A4
±0.15	±0.20	±0.30	±0.30	±0.50	±0.70	±1.00	±1.30	SERIES	KF102
DRAWING TYPE		CUSTOMER DRAWING							
SCALE		1:1		SHEET		1 OF 1			
DRAWING NO.		W15000322							

DF 慈溪市凯峰电子有限公司
CIXI KAIFENG ELECTRONICS CO.,LTD