

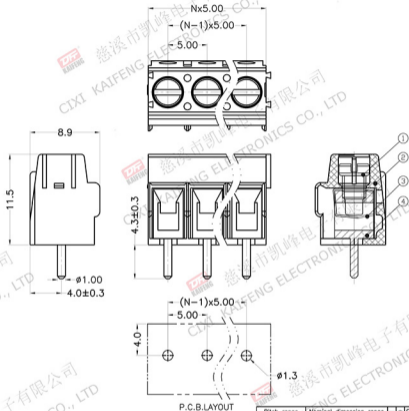

REV.	DESCRIPTION	DATE	DRAFTER	APPROVER
A1	DWG.REL	2020.05.17	DENG	JIN



- Material
  - ØScrews : M2.5 steel, Zinc plated, \*-\* slot type
  - ØHousing : PA66, UL94V-0
  - ØReed : Stainless steel
  - ØPin header : Copper alloy, Tin plated
- Electrical
  - UL IEC
  - Rated voltage : 300V 250V
  - Rated current : 15A 24A
  - Contact resistance : 20mΩ(Max)
  - Insulation resistance : 500MΩ/DC500V
  - Withstanding Voltage : AC2000V/1min
  - Wire range : 24-14AWG 2.5mm<sup>2</sup>
- Mechanical
  - Operating temperature: -40°C~+105°C
  - Soldering temperature: 250°C±5/5sec
  - Torque : 0.4N.m (3.54Lb.in)
  - Strip length : 5-6mm
- RoHS compliance

#### HOW TO ORDER

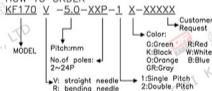

Pitch range	Nominal dimension range	PROJECTION	TITLE
>0	>0	6.1/10	KF170V-5.0-XXP-1X
6	60	<	SHEET SIZE A4
±0.15	±0.30		SERIES KF170
DRAWING TYPE CUSTOMER DRAWING		慈溪市凯峰电子有限公司 CIXI KAIFENG ELECTRONICS CO.,LTD	
SCALE	1:1 SHEET 1 OF 1		
DRAWING NO.	W15000102		