

REV.	DESCRIPTION	DATE	DRAFTER	APPROVER
A1	DWG.REL	2020.05.17	DENG	JIN

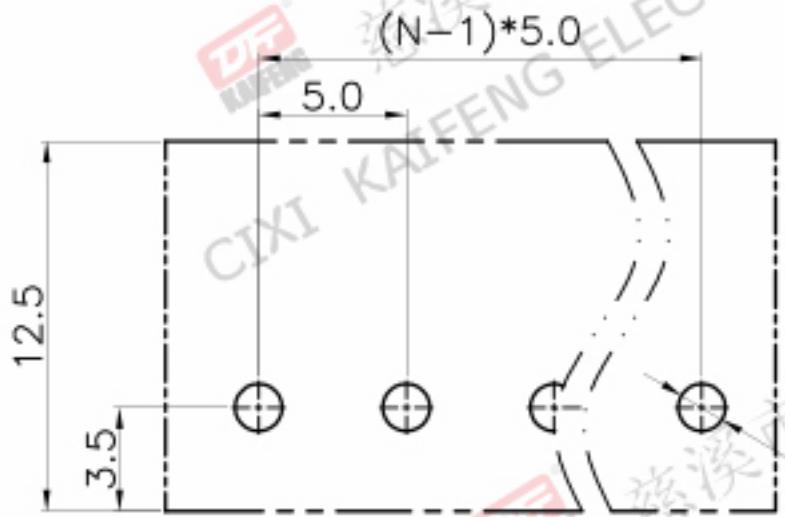

- Material
  - ØScrews : M3.0 steel, Zinc plated, \*- slot type
  - ØHousing : PA66, UL94V-0
  - ØReed : Copper alloy, Ni plated or stainless steel
  - ØPin header : Copper alloy, Tin plated
- Electrical
 

	UL	IEC
Rated voltage :	300V	250V
Rated current :	12A	24A
Contact resistance :	20mΩ(Max)	
Insulation resistance:	500MΩ/DC500V	
Withstanding Voltage :	AC2000V/1min	
Wire range:	22-14AWG	2.5mm <sup>2</sup>
- Mechanical
  - Operating temperature: -30°C ~ +120°C
  - Soldering temperature: 250°C ± 5 / 5sec
  - Torque: 0.5N.m (4.43Lb.in)
  - Strip length: 4.5-5mm
- RoHS compliance

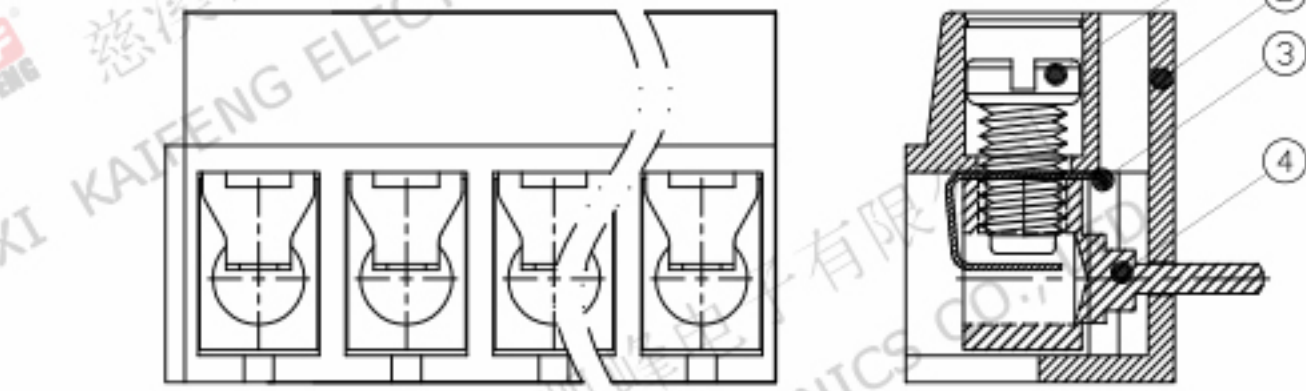
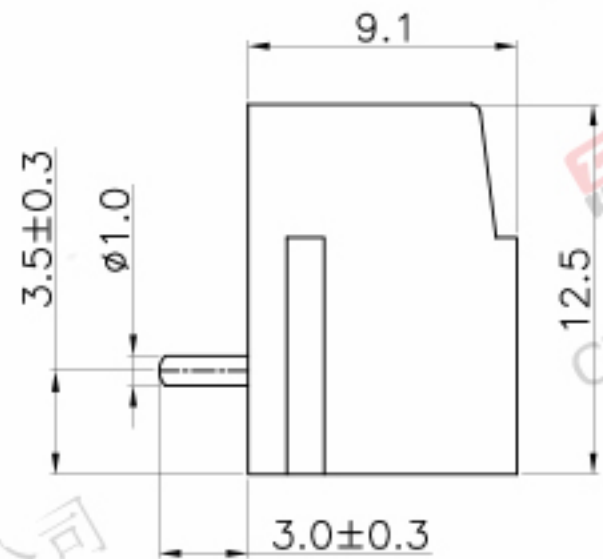
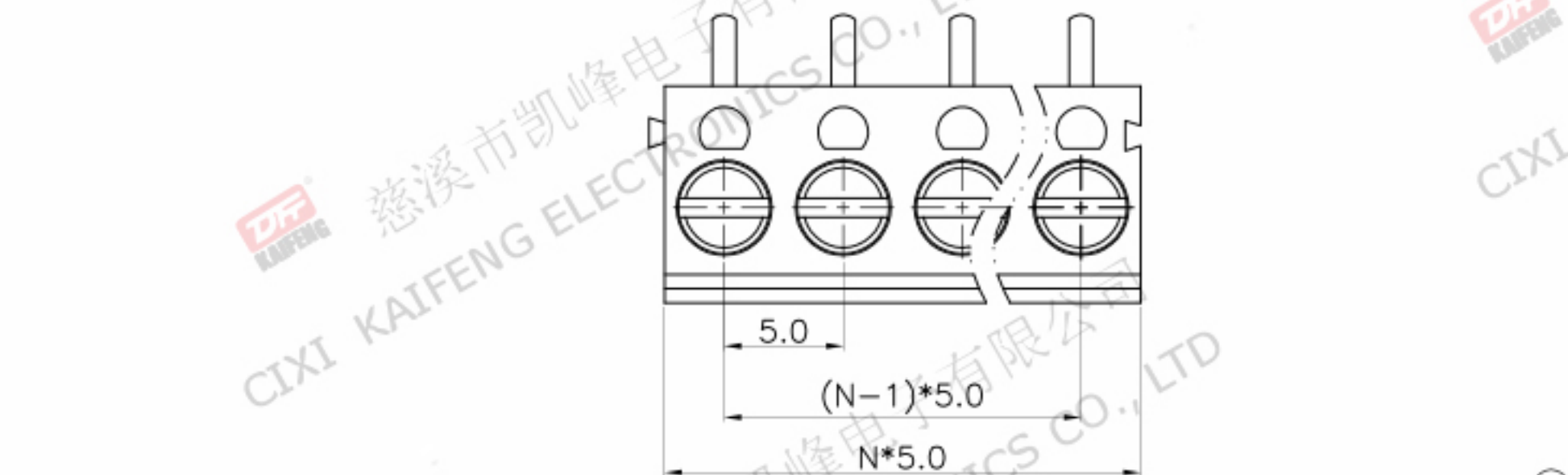
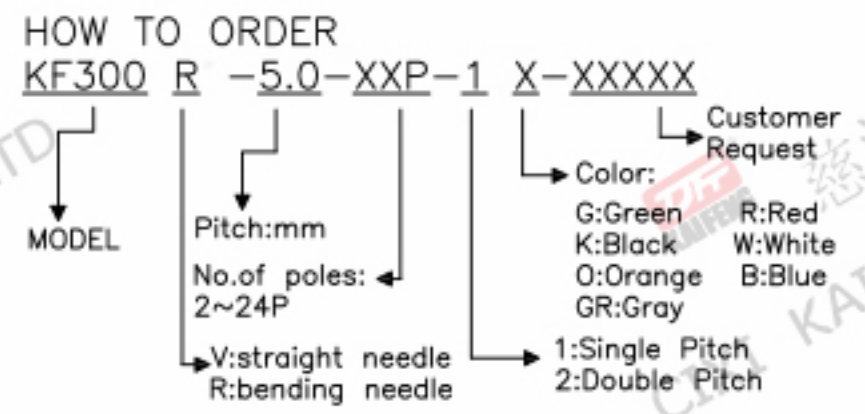

P.C.B.LAYOUT

Pitch range	Nominal dimension range							PROJECTION	TITLE
>0	>6	>10	>0	>30	>60	>100	>150	UNIT	mm
~6	~10	~24	~30	~60	~100	~150	>150	SHEET SIZE	A4
±0.15	±0.20	±0.30	±0.30	±0.50	±0.70	±1.00	±1.30	±2'	
DRAWING TYPE		CUSTOMER DRAWING							
SCALE		1:1		SHEET		1 OF 1			
DRAWING NO.		W15000122							

PROJECTION

TITLE **KF300R-5.0-XXP-1X**

SHEET SIZE A4

SERIES **KF300**

**DF** 慈溪市凯峰电子有限公司  
CIXI KAIFENG ELECTRONICS CO.,LTD

REV.	DESCRIPTION	DATE	DRAFTER	APPROVER
A1	DWG.REL	2020.05.17	DENG	JIN

- Material
  - ØScrews : M3.0 steel, Zinc plated, - slot type
  - ØHousing : PA66, UL94V-0
  - ØReed : Copper alloy, Ni plated or stainless steel
  - ØPin header : Copper alloy, Tin plated

- Electrical
 

UL	IEC
Rated voltage : 300V	250V
Rated current : 12A	24A
Contact resistance : 20mΩ(Max)	
Insulation resistance: 500MΩ/DC500V	
Withstanding Voltage : AC2000V/1min	
Wire range: 22-14AWG	2.5mm <sup>2</sup>

- Mechanical
  - Operating temperature: -30°C ~ +120°C
  - Soldering temperature: 250°C ± 5/5sec
  - Torque: 0.5N.m (4.43Lb.in)
  - Strip length: 4.5-5mm

- RoHS compliance

#### HOW TO ORDER

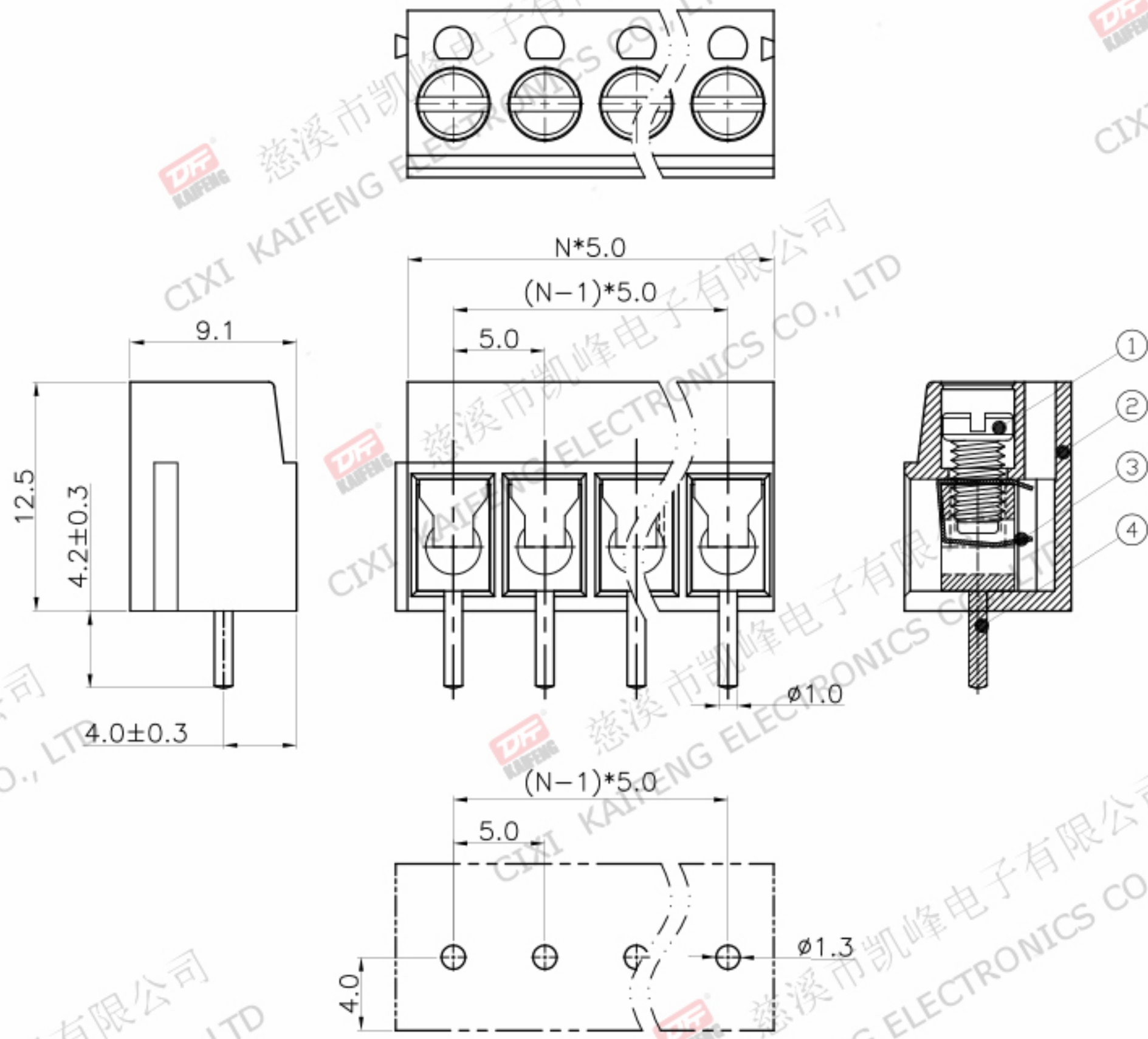
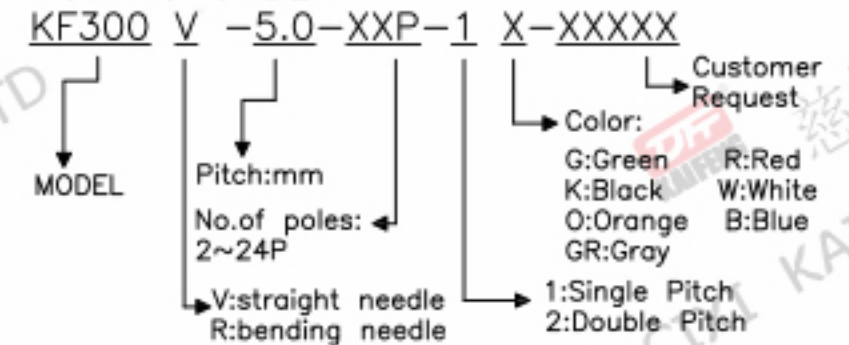

P.C.B.LAYOUT

Pitch range	Nominal dimension range							PROJECTION	TITLE
>0	>6	>10	>0	>30	>60	>100	>150	0.1/10	KF300V-5.0-XXP-1X
~6	~10	~24	~30	~60	~100	~150	<	UNIT mm	SHEET SIZE A4
±0.15	±0.20	±0.30	±0.30	±0.50	±0.70	±1.00	±1.30	±2'	SERIES KF300
DRAWING TYPE		CUSTOMER DRAWING							
SCALE		1:1		SHEET		1 OF 1			
DRAWING NO.		W15000112							

**DF** 慈溪市凯峰电子有限公司  
CIXI KAIFENG ELECTRONICS CO.,LTD