

M12 Female Panel, Crimp, Front fastened, X-coding, Shielded

- Connector series: M12
- Gender: Female
- Coding: X
- Locking type: Fix screw
- Mounting type: Front fastened
- Part No.: MB12FCSXFF08ST-X

X refers to Chasis-side thread size

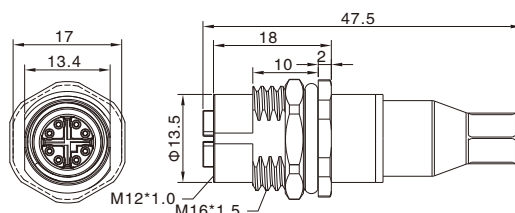

General information



Standard:	IEC 61076-2-109
Ambient temperature:	-40°C ~ +80°C(fixed installation) -20°C ~ +80°C(flexible installation)
Connector insert:	PA / TPU
Connector contacts:	Brass with gold plated
Connector nut/screw:	Brass with nickel plated
Seal / O-ring:	FKM

Insulation resistance:	≥ 100MΩ
Contact resistance :	≤ 10mΩ
Shielding:	Available
IP rating:	IP68 in locked condition
Transmission characteristic:	CAT6A / CAT7
Mating endurance:	>500 cycles

Electrical data & Mechanical data

Contacts	Rated current	Voltage		Wire gauge / size		Cable spec	Part No.
		A/C	D/C	AWG	mm ²		
08 pins	0.5A	50V	60V	27~24AWG	0.14~0.25	CAT6A/CAT7	MB12FCSXFF08ST-X

Note: X refers to Chasis-side thread size

Panel Cut-out Dimensions

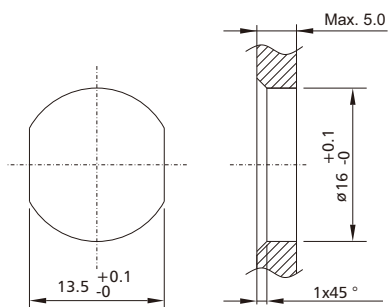

Remarks

- Please refer to Page 578 for the Conversion between American Wire Gauge AWG and Wire Cross-section mm².
- Please refer to Page 96 for products' part number encoding rule.