

## M5 Female Panel Mount, Solder, Front fastened

- Connector series: M5
- Gender: Female
- Coding: A
- Locking type: Fix screw
- Mounting type: Front fastened
- Part No.: MB05FSAFF\*\*ST

\*\*refers to pins number

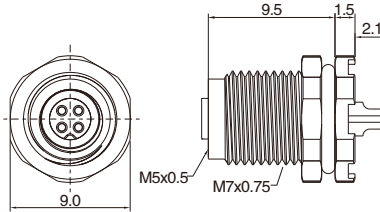

### General information

Standard:	IEC 61076-2-105
Ambient temperature:	-25°C ~ +90°C
Connector insert:	PA + GF
Connector contacts:	Brass with gold plated
Connector nut/screw:	Brass with nickel plated
Seal / O-ring:	Epoxy resin / FKM

Insulation resistance:	≥ 100MΩ
Contact resistance:	≤ 5mΩ
Shielding:	Unavailable
IP rating:	IP67 in locked condition
Mating endurance:	>500 cycles

### Electrical data & Mechanical data

Contacts	Contacts termination	Rated current	Voltage		Wire gauge / size		Wire insulation	Part No.	
			A/C	D/C	AWG	mm <sup>2</sup>			
03 pins		Solder version	1A	60V	60V	26AWG	0.14	PVC wire or customized	MB05FSAFF03ST
04 pins		Solder version	1A	60V	60V	26AWG	0.14	PVC wire or customized	MB05FSAFF04ST

### Panel Cut-out Dimensions

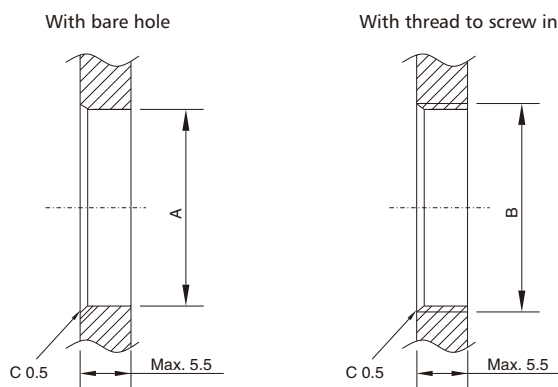

	A	B
M7	7.0 <sup>+0.1</sup> <sub>-0</sub>	M7x0.75

### Remarks

- Please refer to Page 578 for the Conversion between American Wire Gauge AWG and Wire Cross-section mm<sup>2</sup>.
- Please refer to Page 3 for products' part number encoding rule.