

# Automotive Relays

# El.italia serie FW-FRC1H

## Features

- High contact rating (70A)
- High temperature design
- 1 Form A arrangement
- Ideal for use in control-car starter and light
- Quick connect or PC board terminals
- Dust cover

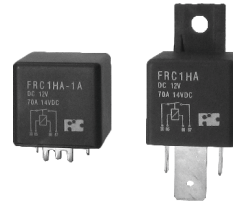

## Ordering information

**FRC1H A - 1 A N DC12V**  
 1 2 3 4 5 6

1 Relay model	5 Coil suppression: NIL: Standard type;
2 Contact arrangement: A: 1 Form A	N: With diode; R : Resistor; T: Transil (DB-03)
3 Mounting termination: NIL: Moulded bracket dust cover;	6 Rated voltage
1 : Dust cover	Note: RoHS : RoHS compliant relay
4 Version: NIL: Plug in type; A: PCB type	RoHS-I : AgNi contact
	RoHS-N: AgSnO <sub>2</sub> contact

## Coil rating

Rated voltage (V)	Coil resistance Ω +/- 10%	Rated current (mA)	Must operate voltage	Must dropout voltage	Maximum voltage	Power consumption (W) Approx.	Operate time (ms)	Release time (ms)
			% of rated voltage (at 20°C)					
6	22.5	267	65 Max.	10 Min.	130 Max.	1.6	<7	<5
12	90	133						
24	360	67						

\*If use resistor:  
 DC 6V with 180Ω resistor  
 DC 12V with 680Ω resistor  
 DC 24V with 2,702Ω resistor

CAUTION: 1. The use of any coil voltage less than the rated coil voltage will compromise the operation of the relay.  
 2. Pickup and release voltage are for test purposes only and are not to be used as design criteria.

## Characteristics

Contact arrangement	SPST (1 Form A)	
Contact material	Silver alloy	
Contact resistance	30mΩ Max.	
Contact rating (resistive)	70A 14VDC	
Switching power	980W Max.	
Switching voltage	DC 75V Max.	
Insulation resistance	100MΩ Min. (at 500VDC)	
Dielectric strength	500VAC (50Hz/min)	
Shock resistance	20g Approx.	
Vibration resistance	1.5mm Double amplitude 10-40Hz	
Ambient temperature	-40°C to +85°C (Special request: -40°C to +105°C)	
Humidity	85% RH, 40°C	
Operation life	Mechanical	10 <sup>7</sup>
	Electrical	10 <sup>5</sup>
Weight	37g Approx.	

(Specifications are subject to change without notices.)

## Dimensions

mm

### Dust cover

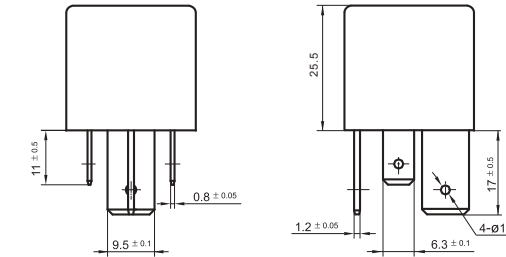

### Mounting holes

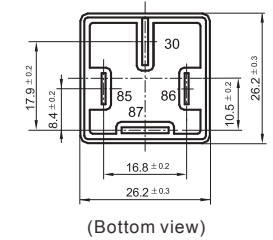

### Moulded bracket dust cover

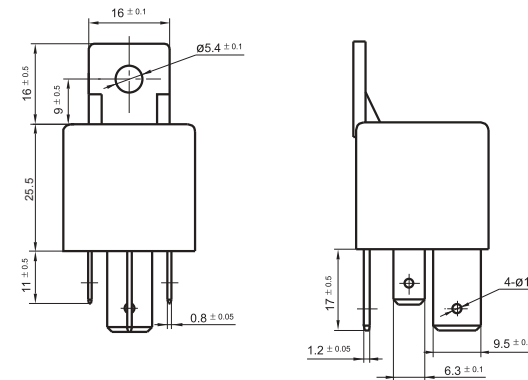

### PCB type

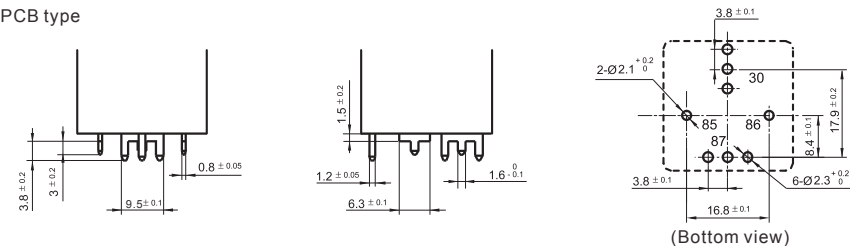

### Wiring diagram

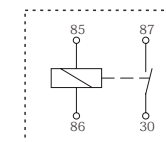

1 Form A

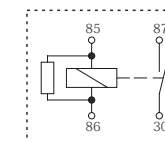

With resistor

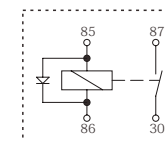

With diode

Reference data

1. Coil operating voltage range

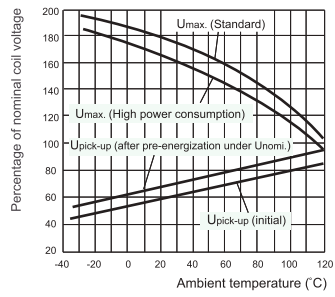

2. Load limit curve

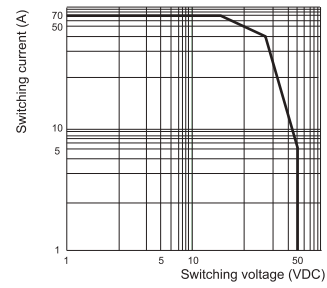

3. Ambient temperature curve of the electrical endurance test

