

Features

- High contact rating (30A)
- High temperature design
- Ideal for use in automobile
- Quick connect terminal



Ordering information

ERC4 A - 1 R - DC12V

1 2 3 4 5

- 1 Relay model
- 2 Contact arrangement: A: 1 Form A
- 3 Mounting termination: 1: Plain Dust cover
- 4 Coil suppression: NIL: Standard type;
R : Resistor; N : Diode

- 5 Rated voltage
- Note: RoHS : RoHS compliant relay
- RoHS-I : AgNi contact
- RoHS-N: AgSnO₂ contact

Coil rating

Rated voltage (V)	Coil resistance Ω +/- 10%	Rated current (mA)	Must operate voltage	Must dropout voltage	Maximum voltage	Power consumption (W) Approx.	Operate time (ms)	Release time (ms)
			% of rated voltage (at 20°C)					
6	20	300						
12	80	150	65 Max.	12.5 Min.	130 Max.	1.8	<7	<5
24	320	75						

CAUTION: 1. The use of any coil voltage less than the rated coil voltage will compromise the operation of the relay.
2. Pickup and release voltage are for test purposes only and are not to be used as design criteria.

Characteristics

Contact arrangement	SPST (1 Form A)	
Contact material	Silver alloy	
Contact resistance	50mΩ Max.	
Contact rating (resistive)	30A 14VDC	
Switching power	420W Max.	
Switching voltage	DC 75V Max.	
Insulation resistance	100MΩ Min. (500VDC)	
Dielectric strength	500VAC (50Hz/min)	
Shock resistance	20g Approx.	
Vibration resistance	1.5mm Double amplitude 10-40Hz	
Ambient temperature	-40°C to +85°C (Special request up to 125°C)	
Humidity	85% RH, 40°C	
Operation life	Mechanical	10 ⁷
	Electrical	10 ⁵ (2 sec on / 2 sec off)
Weight	30g Approx.	

(Specifications are subject to change without notices.)

Dimensions

mm

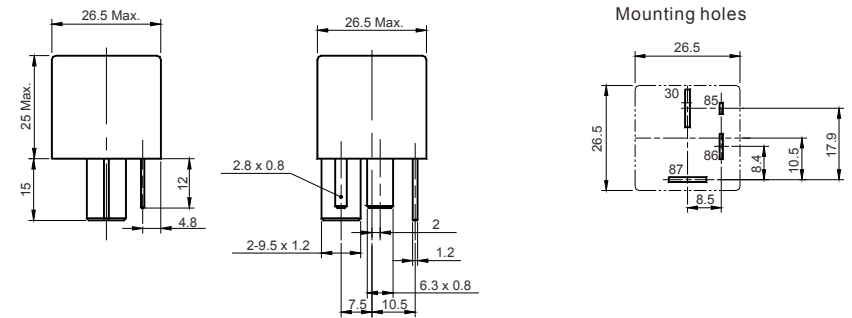

Wiring diagram

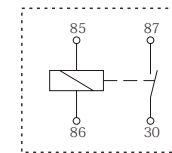

1 Form A

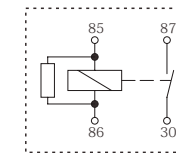

With resistor

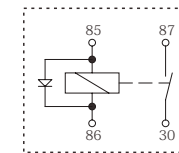

With diode