

FEATURES

- ※ Guiding post offers easy orientation
- ※ Ultra-low profile

APPLICATION

- ※ Notebook
- ※ Smart phone

SPECIFICATION

Contact Rating	1mA, 5V DC
Contact Resistance	2Ω max.
Insulation Resistance	100MΩ min. 100V DC
Dielectric Strength	100V AC/1 minute
Operating Force	50gf max.
Travel	1.03mm
Operating Life	100,000 cycles
Operating Temp.	-10°C ~ +60°C
Storage Temp.	-20°C ~ +70°C

HOW TO ORDER

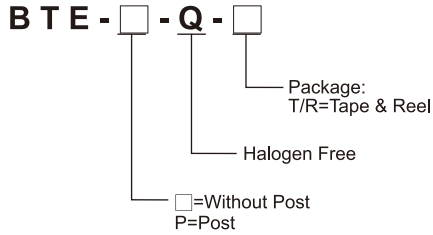

CIRCUIT

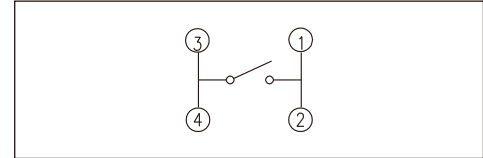

PACKAGE

<Tape & Reel>
2600 pcs

BTE

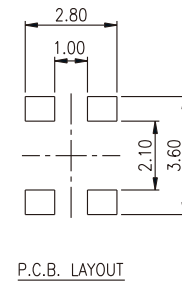
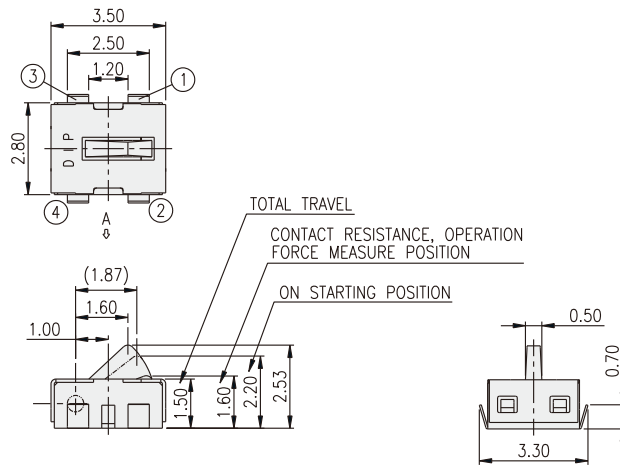

BTE-P

