

# DATA SHEET

SUNGMUN CODE : MSDC-10  
DESCRIPTION : MINI ROTARY DIP SWITCH



REV. NO.	DATE	REVISION	DR	CH	APP
△	23.10.12	DIN ISO-2768-1m tolerance applied	K.N KIM	W.J LEE	K.I LEE

## SPECIFICATION

1. Rating : 100mA, DC 42V (Switching)  
400mA, DC 42V (None-Switching)
2. Contact Resistance : 80mΩ Max
3. Insulation Resistance : 100MΩ Min at DC 250V
4. Operating Force : 120 ±30gf
5. Life cycle : 25,000 steps
6. Sealing : IP67 (Dust & Water proof)
7. Packing : 70pcs Tube

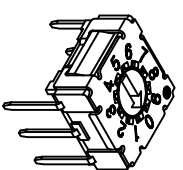
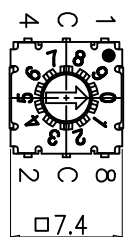
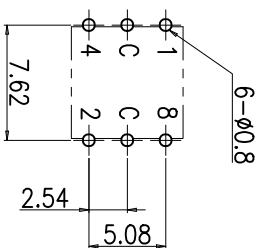

DP 1.05mm  
φ3.2

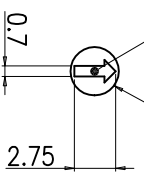

ACTUATOR

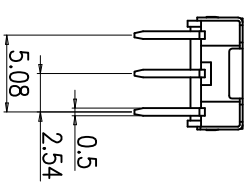
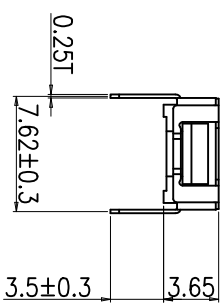

Complement Code	
0	●
1	●
2	●
3	●
4	●
5	●
6	●
7	●
8	●
9	●

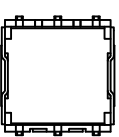

DRAWN/DESIGNED		CHECKED		APPROVED		G.TOL		TITLE	
H.S LEE		K.N KIM		W.J LEE		±0.3		MINI ROTARY DIP SWITCH	
2023-04-14		2023-04-14		2023-04-14		mm		MODEL NO.	
DIN ISO-2768-1m		DIN ISO-2768-1m		DIN ISO-2768-1m		SCALE		SM-MSDC-10	
Ranges		Tolerance		UNIT		N/S		DRAW NO.	
0.5~3		±0.1		mm		N/S		MSDC-10-02	
3~6		±0.1		mm		N/S		REV.	
6~30		±0.2		mm		N/S		02	
30~120		±0.3		mm		N/S			
120~400		±0.5		mm		N/S			



## 1. Style:

This specification describes "7.4X7.4 size of Mini Rotary Dip Switch" which is M series.

1.1 Operating / Storage Temperature Range : -60°C ~ +125°C

## 2. Rating:

2.1 None-Switching : 400 mA, DC 42V

2.2 Switching : 100 mA, DC 42V

3. Type of Actuation : Rotating

## 4. Electrical Characteristics

ITEM	DESCRIPTION	TEST CONDITIONS	REQUIREMENTS
4-1	Visual Examination	By visual examination check without any out pressure & testing.	There shall be no defects that affect the serviceability of the product.
4-2	Contact Resistance	① To be measured between the two terminals associated with each switch pole. ② Measurements shall be made with a 1kHz shall current contact resistance meter.	80mΩ max. (initial)
4-3	Insulation Resistance	250V DC	100 MΩ min.
4-4	Dielectric withstanding Voltage	250V AC(50Hz or 60Hz)shall be applied between all the adjacent terminal and between the terminal and the frame for 1 minute.	There shall be no breakdown or flashover.

## 5. Mechanical Characteristics

ITEM	DESCRIPTION	TEST CONDITIONS	REQUIREMENTS
5-1	Operation Force	Operating direction shall be clockwise or counter clockwise direction	120gf·cm ±30
5-2	Operation Life	Measurements shall be made following the test set forth below: 1)100mA, 42V DC resistive load 2)Rate of operation: 15~20 cycles/ minute 3)Step of operation: 25,000 steps	1)As shown in item 4-3,4-4 2)Contact Resistance: 200mΩ max 3)Final-after test

## 6. Environmental Characteristics

ITEM	DESCRIPTION	TEST CONDITIONS	REQUIREMENTS
6-1	Resistance Low Temperature	Following the test set forth below the sample shall be left in normal temperature and humidity conditions for an hour before measurements are made: 1)Temperature: -60°C ±3°C 2)Time: 96 hours	1)As shown in item 4-3, 4-4, 5-1 2)Contact Resistance: 200mΩ max
6-2	Resistance High Temperature	Following the test set forth below the sample shall be left in normal temperature and humidity conditions for an hour before measurements are made: 1)Temperature: 125°C ±2°C 2)Time: 96 hours	1)As shown in item 4-3, 4-4, 5-1 2)Contact Resistance: 200mΩ max
6-3	Resistance Humidity	Following the test set forth below the sample shall be left in normal temperature and humidity conditions for an hour before measurements are made: 1)Temperature: 40°C ±2°C 2)Relative humidity: 90~95% 3)Time: 96 hours	1)As shown in item 4-4, 5-1 2)Contact Resistance: 200mΩ max 3)Insulation Resistance: 10 MΩ min

7. This item is "RoHS" Compliant

8. Manual Soldering : Max 350°C, 3 sec.

9. Wave Soldering Conditions:

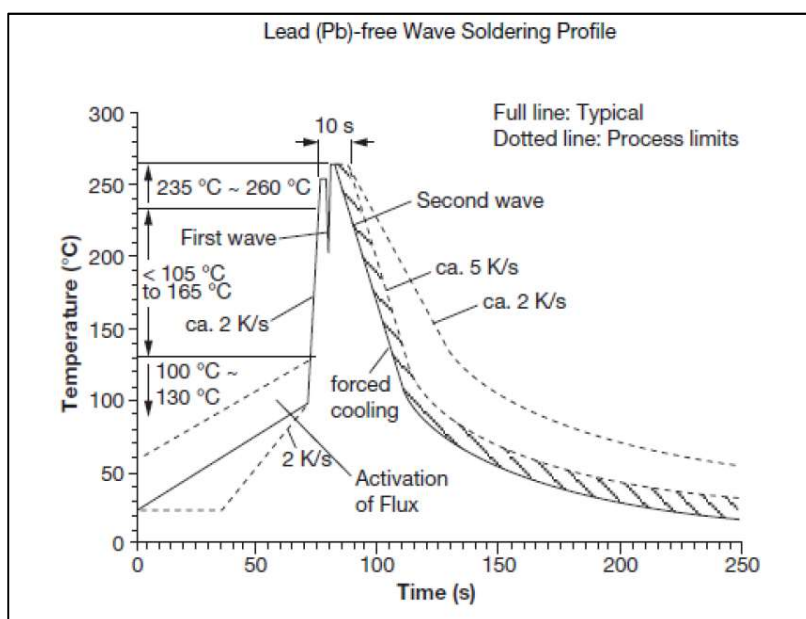

10. Reflow Soldering Conditions: (SMD type only)

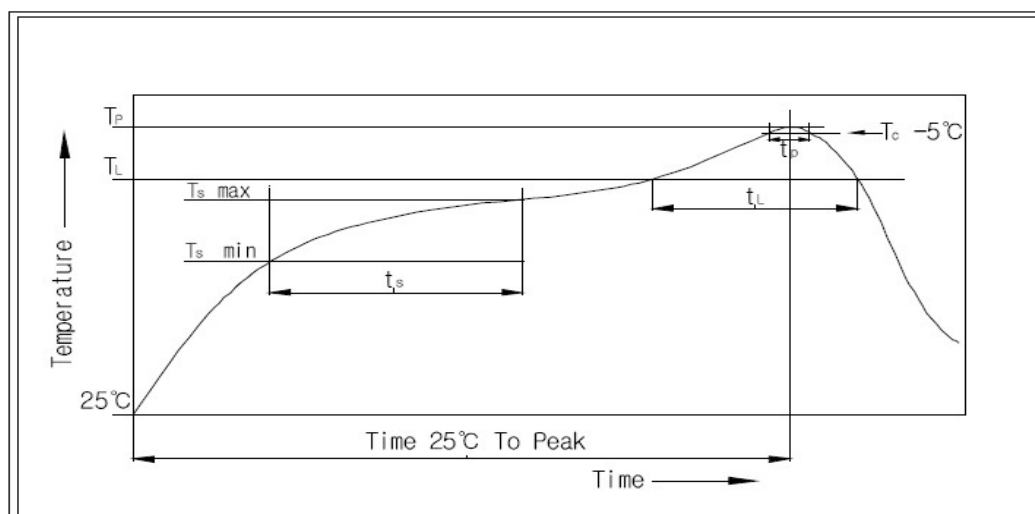

## 10-1 Condition for Soldering

Profile Feature	Pb-Free Assembly
Average Ramp-UP Rate(Ts max to TP)	3°C/second max
Preheat	
- Temperature Min(Ts min)	150°C
- Temperature Max(Ts max)	200°C
- Time (ts min to ts max)	60-180seconds
Time maintained above:	
- Temperature (TL)	217°C
- Time (tL)	60-150seconds
Peak/Classification Temperature(TP)	260°C +0°C/ -5°C
Time within 5°C of actual Peak Temperature(TP)	Min 30 seconds
Ramp-Down Rate	6°C/sec max
Time 25°C to Peak Temperature	8 minutes max



# DATA SHEET

SUNGMUN CODE : MSDC-16  
DESCRIPTION : MINI ROTARY DIP SWITCH



REV. NO.	DATE	REVISION	DR	CH	APP
△	23.10.12	DIN ISO-2768-1m tolerance applied	K.N.KIM	W.J.LEE	K.I.LEE

## SPECIFICATION

1. Rating : 100mA, DC 42V (Switching)  
400mA, DC 42V (None-Switching)
2. Contact Resistance : 80mΩ Max
3. Insulation Resistance : 100MΩ Min at DC 250V
4. Operating Force : 120 ±30gf
5. Life cycle : 25,000 steps
6. Sealing : IP67 (Dust & Water proof)
7. Packing : 70pcs Tube

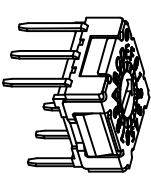
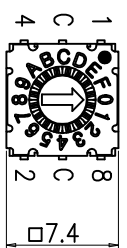
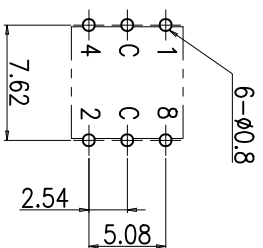

P.C.B DIMENSION (Top View)

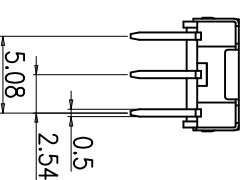
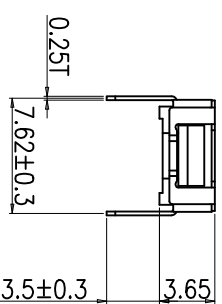
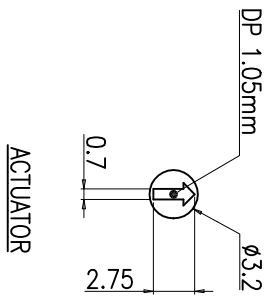

Complement Code					
	C	T	Z	4	8
0	●	●	●	●	0
1	●		●	●	1
2	●	●		●	2
3	●		●	●	3
4	●	●	●		4
5	●		●	●	5
6	●	●		●	6
7	●			●	7
8	●	●	●		8
9	●		●	●	9
10	●	●		●	A
11	●		●		B
12	●	●	●		C
13	●		●		D
14	●	●			E
15	●				F

DIN ISO-2768-1m		2009-05-12		2009-05-12		2009-05-12		G.TOL		TITLE	
Ranges	0.5~3	3~6	6~30	30~120	120~400	J.S SIN	J.P ROH	K.I LEE	±0.3	SM-MSDC-16	MINI ROTARY DIP SWITCH
Tolerance	±0.1	±0.1	±0.2	±0.3	±0.5	UNIT		SCALE	M/S	MODEL NO.	REV.
						mm		N/S		MSDC-16-02	02
SUNGJUN ELECTRONICS CO.,LTD						SIDE		DRAW NO.			
SUNGJUN ELECTRONICS CO.,LTD						A4		MSDC-16-02			



## 1. Style:

This specification describes "7.4X7.4 size of Mini Rotary Dip Switch" which is M series.

1.1 Operating / Storage Temperature Range : -60°C ~ +125°C

## 2. Rating:

2.1 None-Switching : 400 mA, DC 42V

2.2 Switching : 100 mA, DC 42V

3. Type of Actuation : Rotating

## 4. Electrical Characteristics

ITEM	DESCRIPTION	TEST CONDITIONS	REQUIREMENTS
4-1	Visual Examination	By visual examination check without any out pressure & testing.	There shall be no defects that affect the serviceability of the product.
4-2	Contact Resistance	① To be measured between the two terminals associated with each switch pole. ② Measurements shall be made with a 1kHz shall current contact resistance meter.	80mΩ max. (initial)
4-3	Insulation Resistance	250V DC	100 MΩ min.
4-4	Dielectric withstanding Voltage	250V AC(50Hz or 60Hz)shall be applied between all the adjacent terminal and between the terminal and the frame for 1 minute.	There shall be no breakdown or flashover.

## 5. Mechanical Characteristics

ITEM	DESCRIPTION	TEST CONDITIONS	REQUIREMENTS
5-1	Operation Force	Operating direction shall be clockwise or counter clockwise direction	120gf·cm ±30
5-2	Operation Life	Measurements shall be made following the test set forth below: 1)100mA, 42V DC resistive load 2)Rate of operation: 15~20 cycles/ minute 3)Step of operation: 25,000 steps	1)As shown in item 4-3,4-4 2)Contact Resistance: 200mΩ max 3)Final-after test

## 6. Environmental Characteristics

ITEM	DESCRIPTION	TEST CONDITIONS	REQUIREMENTS
6-1	Resistance Low Temperature	Following the test set forth below the sample shall be left in normal temperature and humidity conditions for an hour before measurements are made: 1)Temperature: -60°C ±3°C 2)Time: 96 hours	1)As shown in item 4-3, 4-4, 5-1 2)Contact Resistance: 200mΩ max
6-2	Resistance High Temperature	Following the test set forth below the sample shall be left in normal temperature and humidity conditions for an hour before measurements are made: 1)Temperature: 125°C ±2°C 2)Time: 96 hours	1)As shown in item 4-3, 4-4, 5-1 2)Contact Resistance: 200mΩ max
6-3	Resistance Humidity	Following the test set forth below the sample shall be left in normal temperature and humidity conditions for an hour before measurements are made: 1)Temperature: 40°C ±2°C 2)Relative humidity: 90~95% 3)Time: 96 hours	1)As shown in item 4-4, 5-1 2)Contact Resistance: 200mΩ max 3)Insulation Resistance: 10 MΩ min

7. This item is "RoHS" Compliant

8. Manual Soldering : Max 350°C, 3 sec.

9. Wave Soldering Conditions:

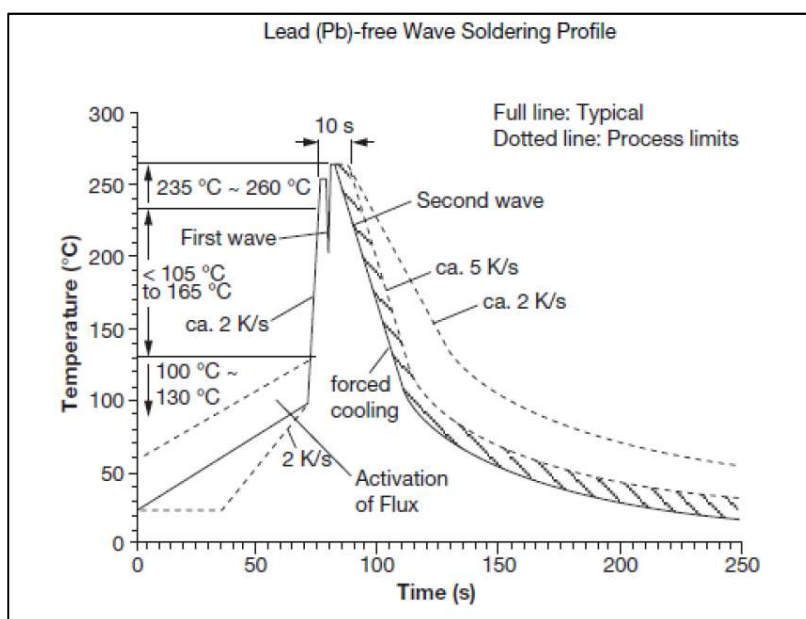

10. Reflow Soldering Conditions: (SMD type only)

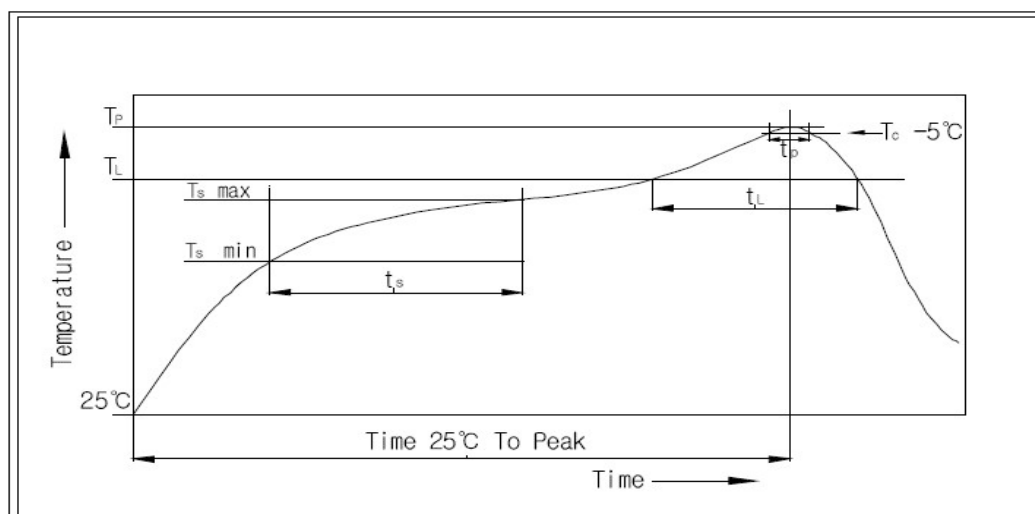

## 10-1 Condition for Soldering

Profile Feature	Pb-Free Assembly
Average Ramp-UP Rate(Ts max to TP)	3°C/second max
Preheat	
- Temperature Min(Ts min)	150°C
- Temperature Max(Ts max)	200°C
- Time (ts min to ts max)	60-180seconds
Time maintained above:	
- Temperature (TL)	217°C
- Time (tL)	60-150seconds
Peak/Classification Temperature(TP)	260°C +0°C/ -5°C
Time within 5°C of actual Peak Temperature(TP)	Min 30 seconds
Ramp-Down Rate	6°C/sec max
Time 25°C to Peak Temperature	8 minutes max