

REV NO.	DATE	REVISION	DR	CH	APP
△					

SPECIFICATION

1. Rating : DC12V 0.5A~24V 0.3A.
2. Contact Resistance : 80mΩ Max.
3. Travel : 1.6mm.
4. Operating Force : 250gf ± 150gf.
5. Life Cycle : 2,000 Cycle (with load).
6. Packing : 200pcs Vinyl Bag

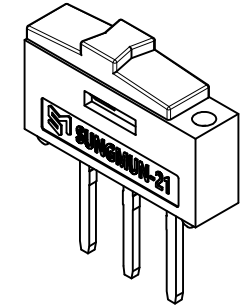
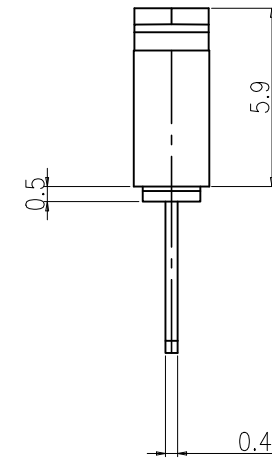
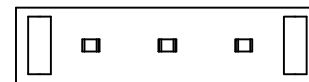
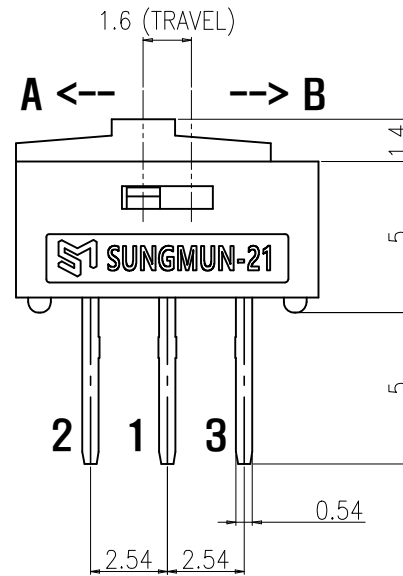
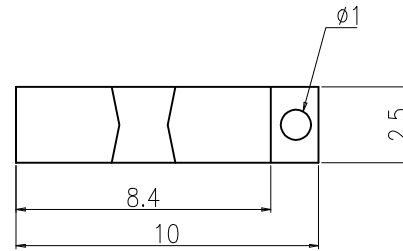
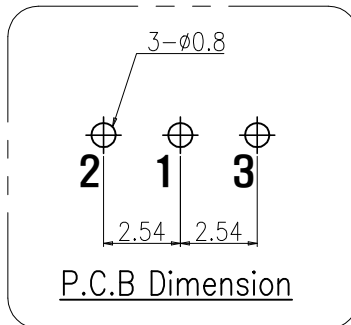
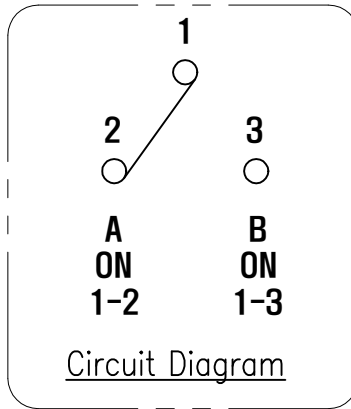

EL.ITALIA
COMPONENTI ELETTRONICI
ED Elettromeccanici DAL 1981

Din ISO-2768-1m						SUNGMUN ELECTRONICS CO.,LTD	
Ranges	0.5~3	3~6	6~30	30~120	120~400	UNIT	SCALE
Tolerance	±0.1	±0.1	±0.2	±0.3	±0.5	mm	N:S
							A4

01 NO.	DESCRIPTION	MATERIAL	COLOR / FINISH	REMARK
DRAW/DESIGNED	CHECKED	APPROVED	G.TOL	TITLE
K.N KIM	W.J LEE	K.I LEE	--	MINI SLIDE SWITCH
2023-05-26	2023-05-26	2023-05-26	UNIT	MODEL NO.
			SCALE	SM-NSI-21
			SIZE	NSI-21-01
			DRAW NO.	REV.
				01

REV NO.	DATE	REVISION	DR	CH	APP
△					

SPECIFICATION

1. Rating : DC12V 0.5A~24V 0.3A.
2. Contact Resistance : 80mΩ Max.
3. Travel : 1.6mm.
4. Operating Force : 250gf ± 150gf.
5. Life Cycle : 2,000 Cycle (with load).
6. Packing : 200pcs Vinyl Bag / 700pcs Reel Packing

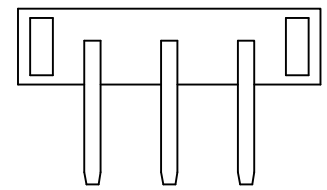
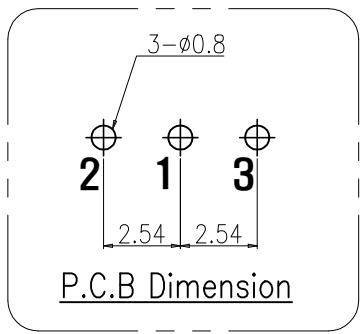
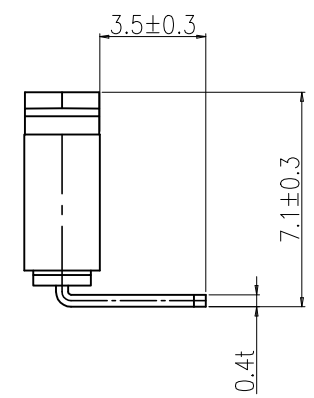
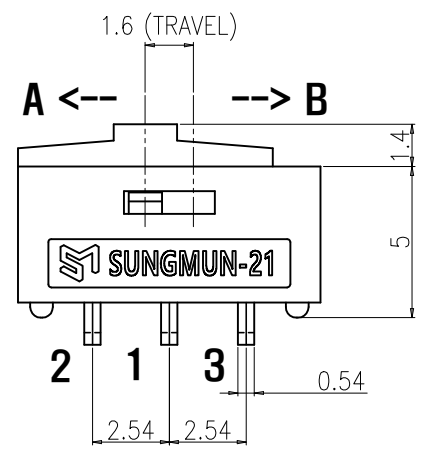
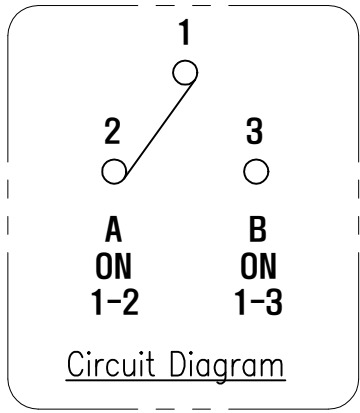
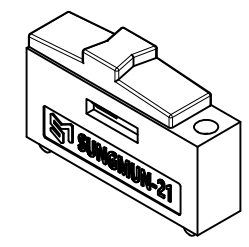
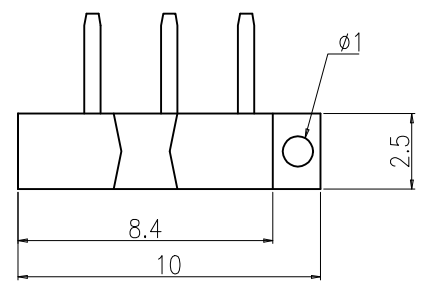

Din ISO-2768-1m						01		-		-		-		
Ranges	0.5~3	3~6	6~30	30~120	120~400	2024-02-26	2024-02-26	2024-02-26	mm	UNIT	SCALE	MODEL NO.	SM-NSI-21H	REV.
Tolerance	±0.1	±0.1	±0.2	±0.3	±0.5	SUNGMUN ELECTRONICS CO.,LTD			mm	---	N:S	NSI-21H-01	01	
						DRAW/DESIGNED		CHECKED		APPROVED		TITLE		REMARK
						K.N KIM		W.J LEE		K.I LEE		MINI SLIDE SWITCH		
						G.TOL		SCALE		SIZE		DRAW NO.		
						---		A4		A4		NSI-21H-01		

REV NO.	DATE	REVISION	DR	CH	APP
△					

SPECIFICATION

1. Rating : DC12V 0.5A~24V 0.3A.
2. Contact Resistance : 80mΩ Max.
3. Travel : 1.6mm.
4. Operating Force : 250gf ± 150gf.
5. Life Cycle : 2,000 Cycle (with load).
6. Packing : 200pcs Vinyl Bag / 1,500pcs Reel Packing

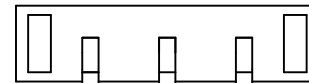
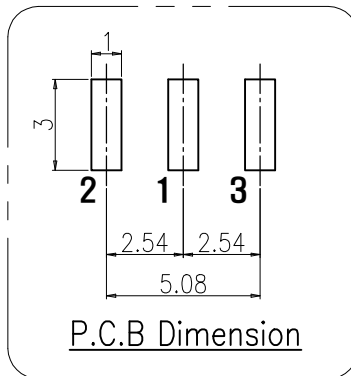
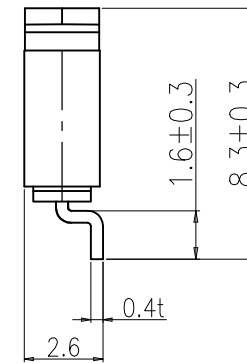
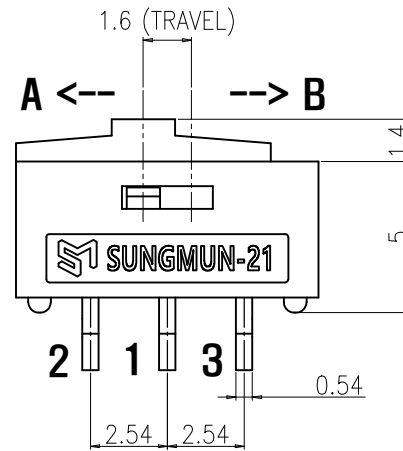
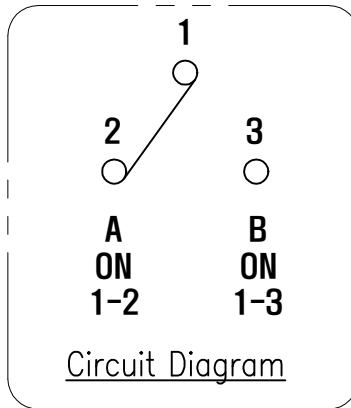
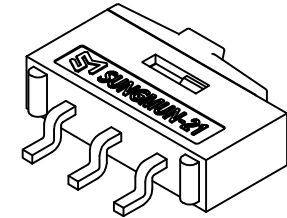
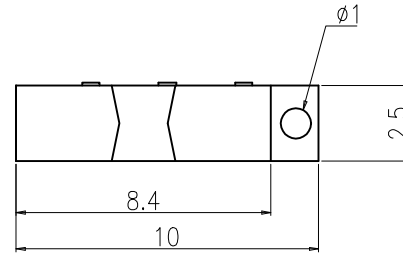

EL.ITALIA
COMPONENTI ELETTRONICI
ED ELETTROMECCANICI DAL 1981

Din ISO-2768-1m						SUNGMUN ELECTRONICS CO.,LTD		REV.					
Ranges	0.5~3	3~6	6~30	30~120	120~400	2024-04-25	2024-04-25	2024-04-25	mm				
Tolerance	±0.1	±0.1	±0.2	±0.3	±0.5	SUNGMUN ELECTRONICS CO.,LTD		UNIT	SCALE	MODEL NO.	SM-NSI-21HS		REV.
								mm	N:S	NSI-21HS-01	SM-NSI-21HS		01
								SIZE	A4	DRAW NO.	NSI-21HS-01		01

REV NO.	DATE	REVISION	DR	CH	APP
△					

SPECIFICATION

1. Rating : DC12V 0.5A~24V 0.3A.
2. Contact Resistance : 80mΩ Max.
3. Travel : 1.6mm.
4. Operating Force : 250gf ± 150gf.
5. Life Cycle : 2,000 Cycle (with load).
6. Packing : 200pcs Vinyl Bag / 700pcs Reel Packing

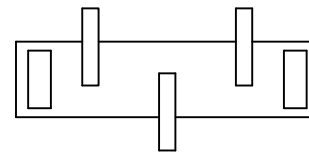
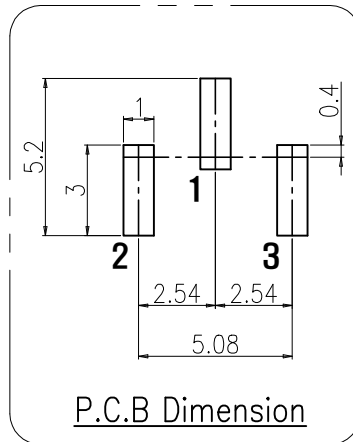
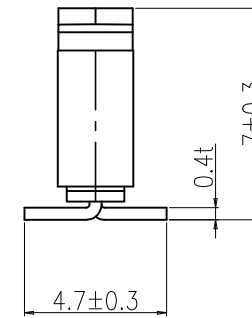
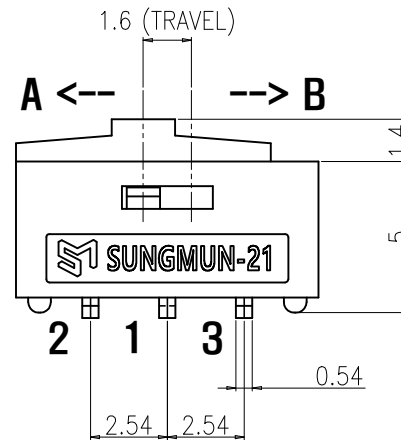
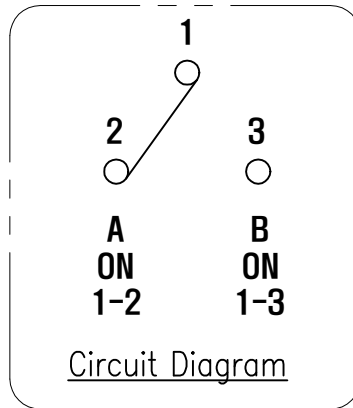
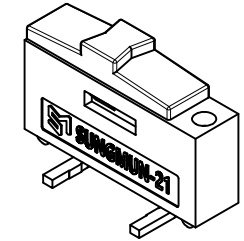
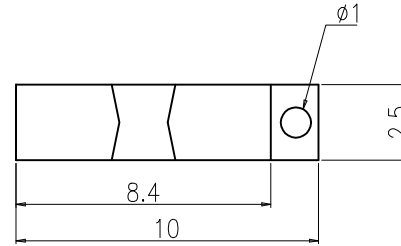

Din ISO-2768-1m					
Ranges	0.5~3	3~6	6~30	30~120	120~400
Tolerance	±0.1	±0.1	±0.2	±0.3	±0.5

01	-			-		-		-	
NO.	DESCRIPTION			MATERIAL		COLOR / FINISH		REMARK	
	DRAW/DESIGNED	CHECKED	APPROVED		G.TOL	TITLE	MINI SLIDE SWITCH		
	K.N KIM	W.J LEE	K.I LEE		--				
	2024-02-26	2024-02-26	2024-02-26	UNIT	SCALE	MODEL NO.	SM-NSI-21S		REV.
	SUNGMUN ELECTRONICS CO.,LTD				mm	N:S	NSI-21S-01		01
					SIZE	DRAW NO.			
					A4				