

S2S-B15LC

FEATURES

- ※2.0mm height
- ※Double-side recoil
- ※Stroke 1.5mm

APPLICATION

- ※Remote control
- ※Consumer electronics
- ※Instrumentations

SPECIFICATION

Contact Rating	300mA, 4V DC
Contact Resistance	70mΩ max.
Insulation Resistance	100MΩ min. 100V DC
Dielectric Strength	100V AC/1 minute
Operating Force	100±50gf
Travel	1.5mm
Operating Life	50,000 cycles
Operating Temp.	-30°C ~ +80°C
Storage Temp.	-40°C ~ +90°C

HOW TO ORDER

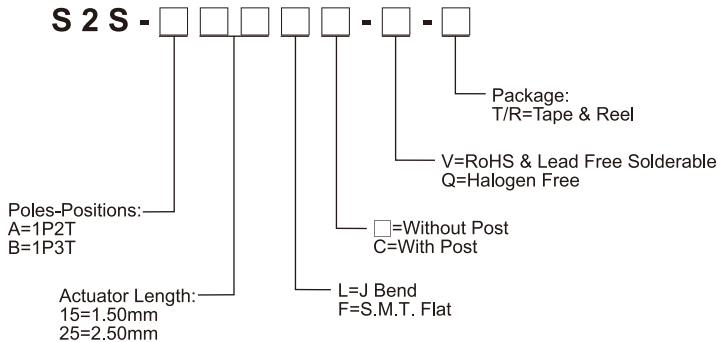

CIRCUIT

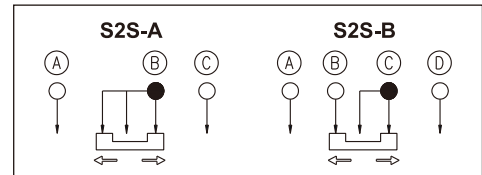

PACKAGE

<Tape & Reel>
2000 pcs

S2S-A [] [] [] F

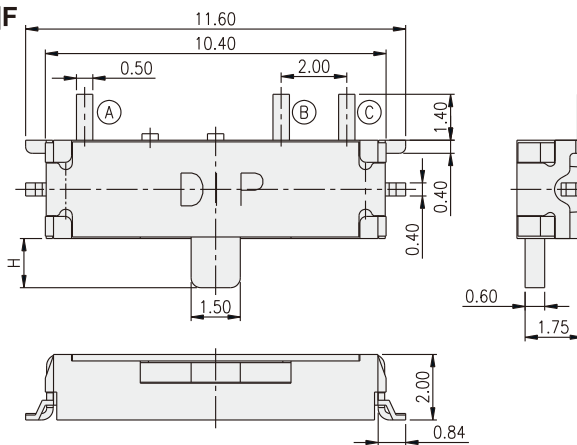

PART NO.	H
S2S-A15F	1.50
S2S-A25F	2.50

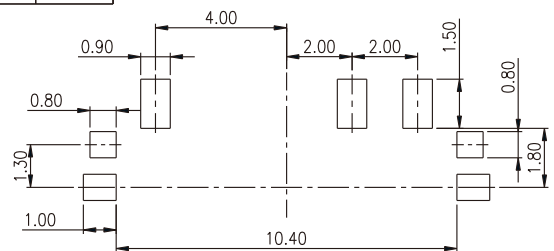

P.C.B. LAYOUT

S2S-B [] [] [] LC

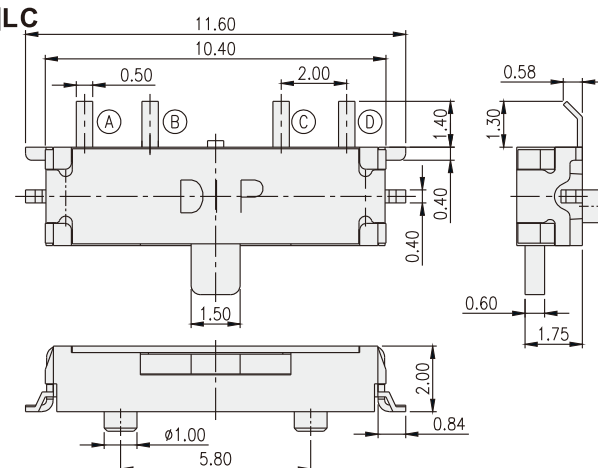

PART NO.	H
S2S-B15LC	1.50
S2S-B25LC	2.50

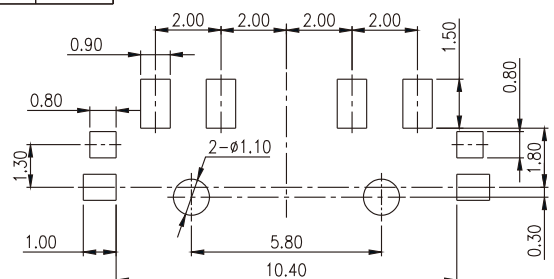

P.C.B. LAYOUT