

SLIDE SWITCH SC12P SERIES

Slide Type (1P2T)

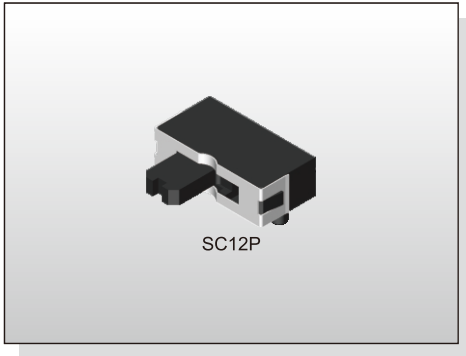

FEATURES

- ✘ 3.0mm height
- ✘ Through hole type
- ✘ 1P2T model

APPLICATION

- ✘ Remote control
- ✘ Consumer electronics
- ✘ Instrumentations

SPECIFICATION

Contact Rating	0.3A, 10V DC
Contact Resistance	50mΩ max.
Insulation Resistance	100MΩ min. 500V DC
Dielectric Strength	500V AC/1 minute
Operating Force	100~300gf
Travel	2.5mm
Operating Life	10,000 cycles
Operating Temp.	-10°C ~ +60°C
Storage Temp.	-20°C ~ +75°C

HOW TO ORDER

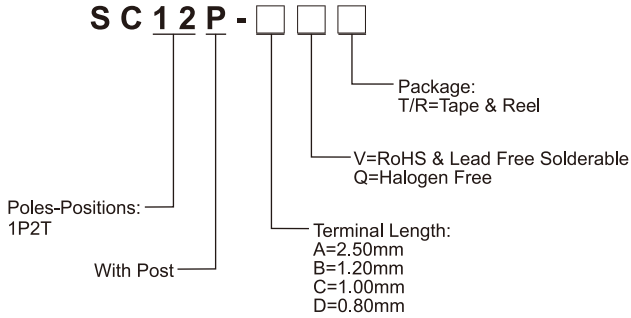

CIRCUIT

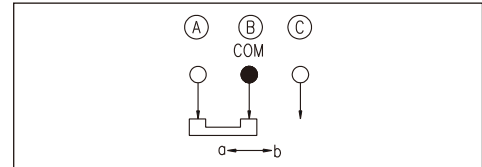

PACKAGE

<Tape & Reel>
650 pcs

SLIDE SWITCH

SC12P

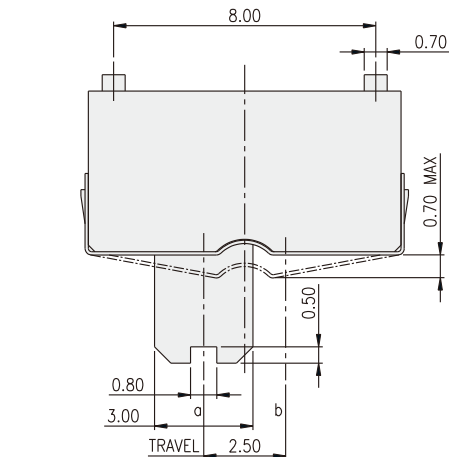

PART NO.	L
SC12P-A	2.50
SC12P-B	1.20
SC12P-C	1.00
SC12P-D	0.80

