

TACT SWITCH TA(C)(2)-3 SERIES

3.95x7.3 / 4.65x7.0
SMT & Side Push Type

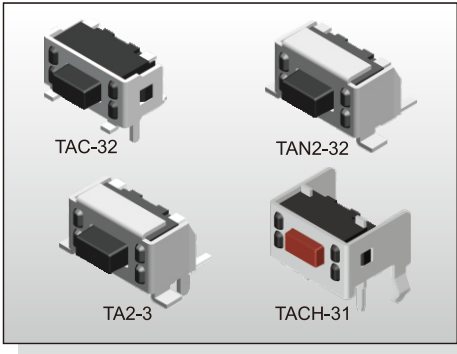

FEATURES

- ※Side actuated
- ※Support/Ground pin option
- ※High solder strength

APPLICATION

- ※Data storage, Server
- ※Instrumentation
- ※Audio, OA equipment

SPECIFICATION

Contact Rating	50mA, 12V DC	
Contact Resistance	100mΩ max.	
Insulation Resistance	100MΩ min. 500V DC	
Dielectric Strength	250V AC/1 minute	
Operating Force	160±50gf, 260±50gf	TAC-3
	160±50gf, White(W)	TA2-3
	160±50gf, Brown(N)	
	320±50gf, Salmon(S)	
Travel	0.25mm	
Operating Life	50,000 cycles	
Operating Temp.	-25°C ~ +70°C	
Storage Temp.	-40°C ~ +80°C	

HOW TO ORDER

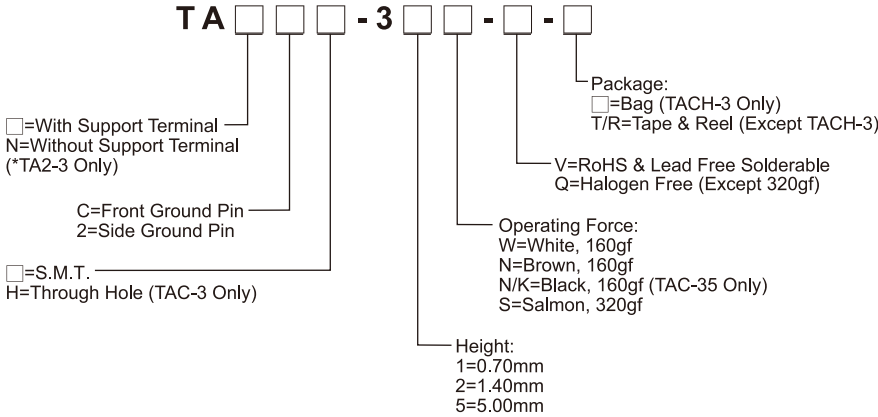

CIRCUIT

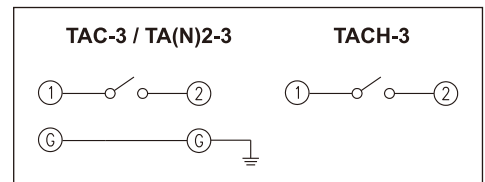

PACKAGE

<Bag>
500 pcs(TACH-3 Only)

<Tape & Reel>
900 pcs

TAC-3

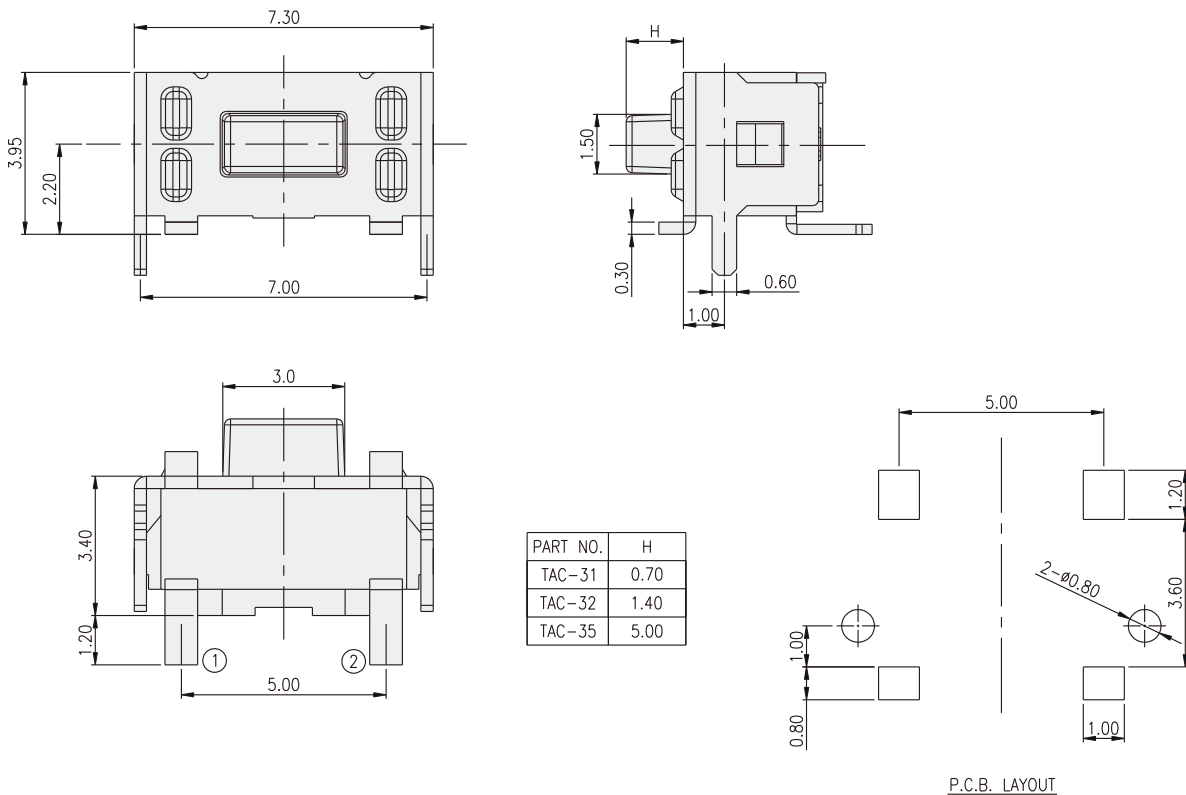

TACT SWITCH
TA(C)2-3 SERIES

3.95x7.3 / 4.65x7.0
 SMT & Side Push Type



TA2-3

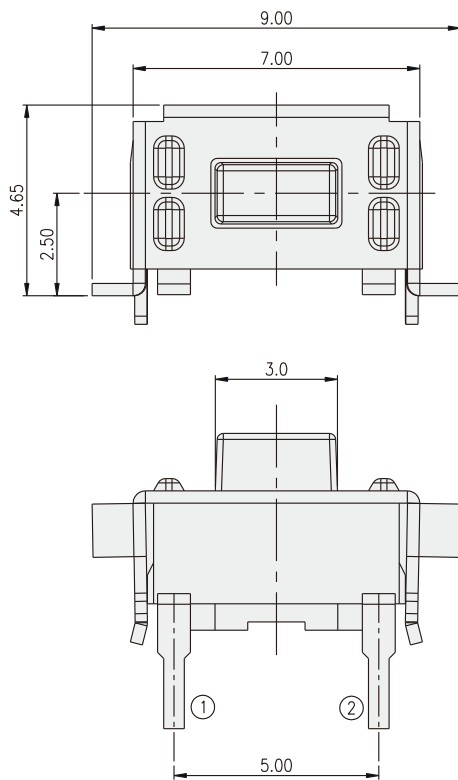

PART NO.	H
TA2-31	0.70
TA2-32	1.40
TA2-35	5.00

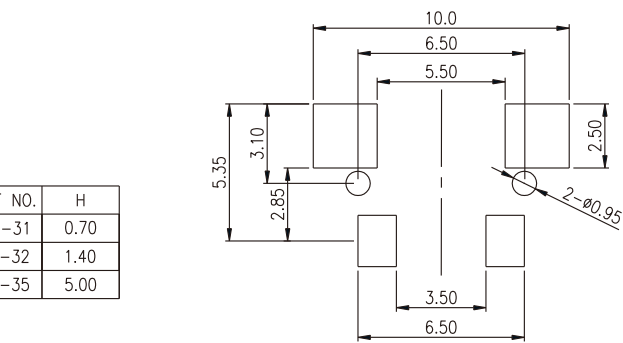

P.C.B. LAYOUT

TACT SWITCH

TAN2-3

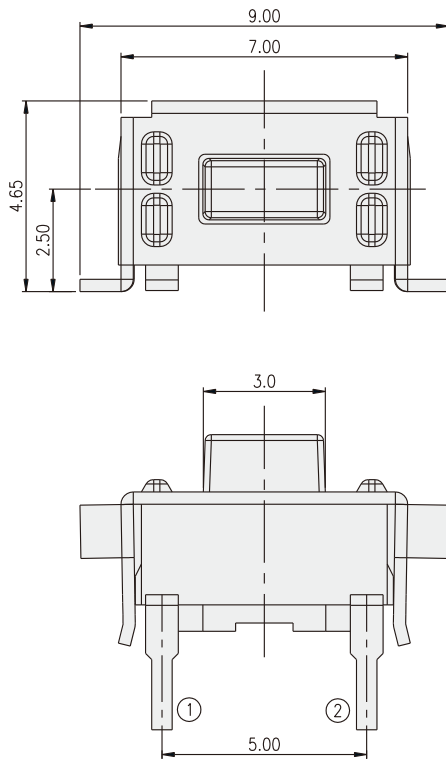

PART NO.	H
TAN2-31	0.70
TAN2-32	1.40
TAN2-35	5.00

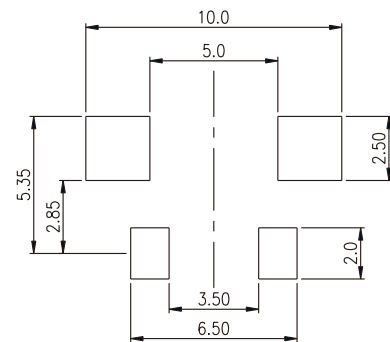

P.C.B. LAYOUT

TACH-3

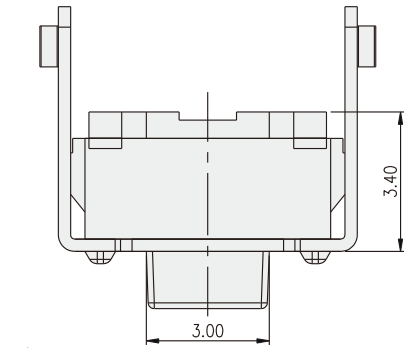

PART NO.	H	L
TACH-31	0.70	3.15
TACH-32	1.40	3.85
TACH-35	5.00	7.45

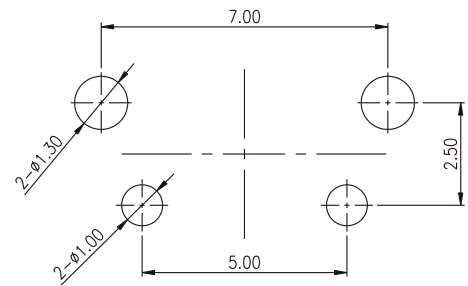
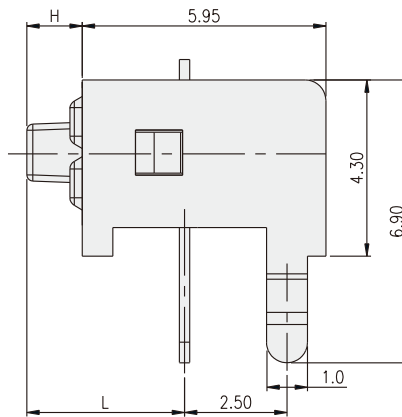
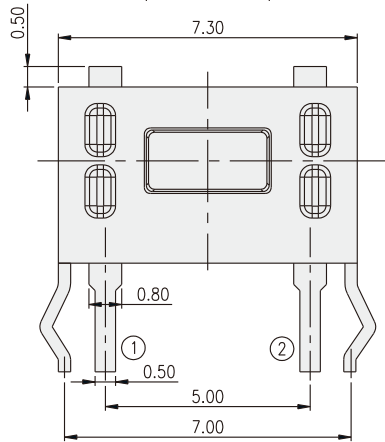

P.C.B. LAYOUT

TACT SWITCH