

**NEW**

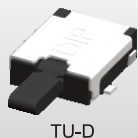

TU-D

**FEATURES**

- ※F or L terminations
- ※Long Travel type
- ※50,000 operation life cycles

**APPLICATION**

- ※Consumer electronics
- ※Detection of video cameras
- ※Open/close detection
- ※Safety control device
- ※Heat energy regulator

**SPECIFICATION**

Contact Rating	50uA, 3V DC to 10mA, 5V DC
Contact Resistance	1Ω max.
Insulation Resistance	100MΩ min.
Dielectric Strength	100V AC/1 minute
Operating Force	40gf max.
Travel	60°
Operating Life	50,000 cycles
Operating Temp.	-10°C ~ +60°C
Storage Temp.	-20°C ~ +70°C

**HOW TO ORDER**

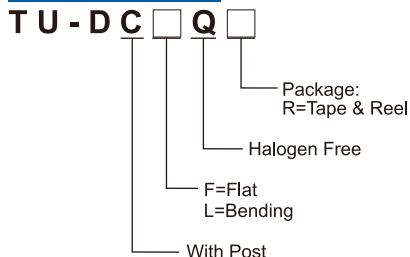

**CIRCUIT**

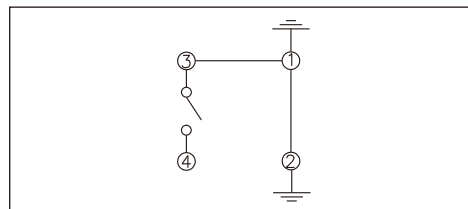

**PACKAGE**

<Tape & Reel>  
3500 pcs

**TU-DF**

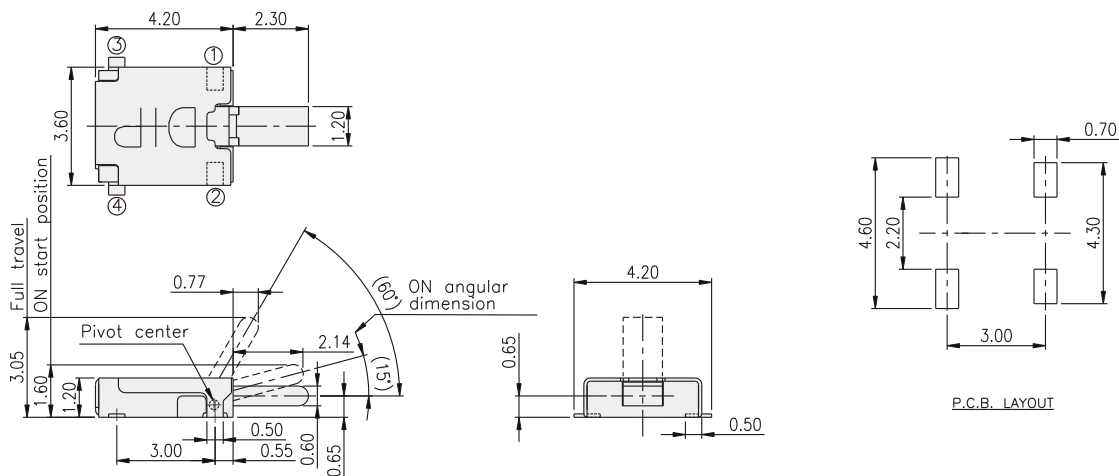

**TU-DCL**

