

FEATURES

- ※Ultra-thin with height 1.2 mm
- ※Flat & bending terminal available

APPLICATION

- ※Detection of video cameras
- ※Mobile Phone

SPECIFICATION

Contact Rating	50uA, 3V DC to 10mA, 5V DC
Contact Resistance	1Ω max.
Insulation Resistance	100MΩ min.
Dielectric Strength	100V AC/1 minute
Operating Force	40gf max.
Travel	60°
Operating Life	50,000 cycles
Operating Temp.	-10°C ~ +60°C
Storage Temp.	-20°C ~ +70°C

HOW TO ORDER

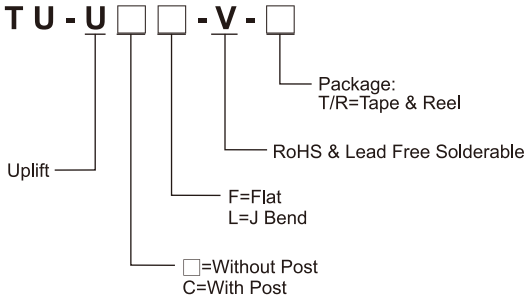

CIRCUIT

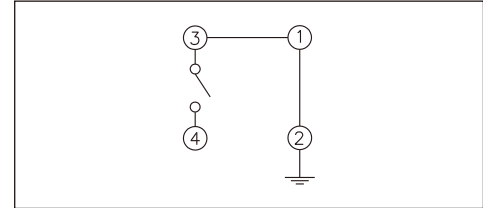

PACKAGE

<Tape & Reel>
2300 pcs

TU-UL

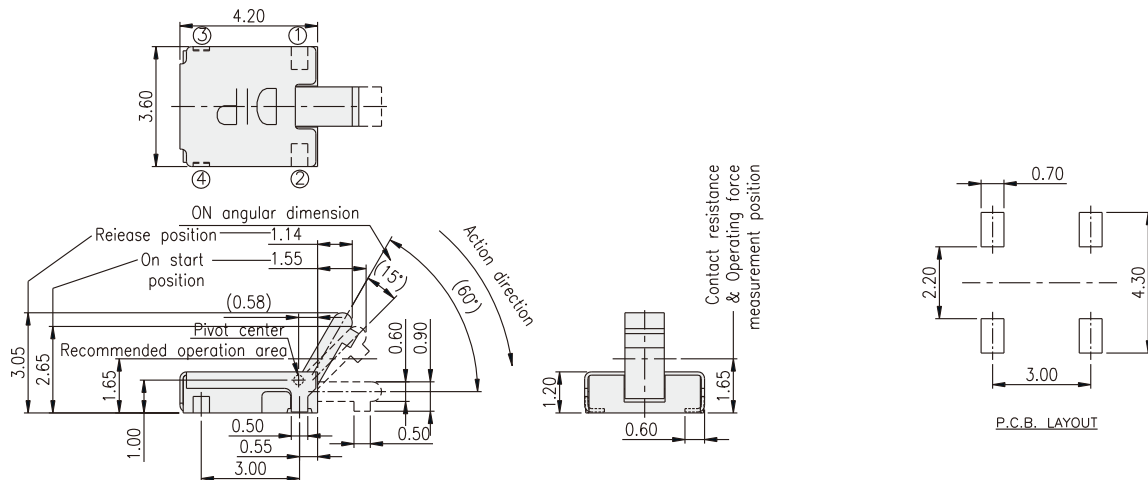

TU-UCF

